

WCC 106 A

Installation instruction

MotorController

(Version 2311)



Save this installation manual for the end user

The latest version of this document can always be found on our website

UK +44 1536 614070 info.uk@windowmaster.com
Others +45 45 670 300 info.dk@windowmaster.com

www.windowmaster.com

1	Safety regulations	3
1.1	Safety	3
1.2	230V AC	3
1.3	Application	3
1.4	Cabling and electrical connection	3
2	Introduction to WCC 106 A	3
2.1	The MotorController's construction	3
2.2	MotorController variants	4
2.3	Max number of actuators per MotorController	4
3	Accessories	5
4	Technical data	5
5	Mounting	6
6	Installation	6
6.1	Cable routing	6
6.2	Connecting cables in the MotorController	6
6.3	Connecting protective earth and 230V AC	6
6.4	Installation of comfort keypad	6
6.5	Assembly instructions	7
7	Cable dimensioning	7
7.1	Max. cable length	7
7.1.1	Formula for calculating max. actuator cable length	7
7.1.2	Max. cable length – $\pm 24V$ standard actuators	7
7.1.3	Max cable length – actuators with MotorLink [®]	8
8	Connection plan for WCC 106 A	9
9	Connection description	10
10	DIP switch configuration	14
11	Control via remote control – WCA 100	15
11.1	Before use	16
11.1.1	Pairing of remote control and MotorController	16
12	Control via app – Fresh Air Control	16
13	Status and troubleshooting via LED on the MotorController	16
14	Commissioning and test run	17
14.1	MotorController fully installed, without operating power	17
14.2	With network power	18
14.3	Remote control and comfort keypad	18
14.4	Wind/rain sensor	18
15	Maintenance	18
15.1	Maintenance agreement	18
16	Components declaration	18

1 Safety regulations

1.1 Safety

Only allow correspondingly trained, qualified and skilled personnel to carry out installation work.

Reliable operation and the avoidance of damage and hazards are only guaranteed if installation and settings are carried out carefully in accordance with these instructions.

There may be personal danger by electrically operated windows:

- the forces occurring in the automatic mode can be such that parts of the body could get crushed
- when opened, actuators (spindles) could protrude into the room

For this reason, measures have to be taken prior to starting up the actuators, which exclude the danger of injury.

For safety reasons we recommend installing opening restrictors on bottom-hung windows.

In the event that windows are subjected to rain and/or high wind loads, we recommend connecting a wind/rain sensor to the MotorController for the automatically closing of the windows.

The MotorController is to be located in a safe place, protected from the effects of fire and smoke.

The MotorController is to be surface mounted.

The MotorController is supplied by 230V AC.

The manufacturer does not assume any liability for possible damage resulting from inappropriate use.

1.2 230V AC

230V AC can cause death, severe bodily injury, or significant damage to property.

The MotorController must be disconnected from the power supply before being opened, mounted, or performing any alteration of the construction.

Power supply to the MotorController must be done via external two-pole or multi-pole circuit breaker. The MotorController is to be supplied with Phase conductor, Neutral conductor and Earth conductor

Applicable national regulations must be complied with.

1.3 Application

The MotorController is solely designed for the automatic opening and closing of windows, flaps and doors.

Always check that the system complies with applicable national regulations.

The cable cross section will depend on wire length and power consumption. See chapter "Cable dimensioning".

1.4 Cabling and electrical connection

WindowMaster recommends powering the MotorController from its own group.

Cable routing and connection - adhere to national regulations.

Establish the cable types, if necessary, with the local approval bodies.

Do not conceal flexible cables.

Junction box must be accessible for maintenance purposes.

Disconnect all poles of the mains voltage prior to starting maintenance work or making changes to the system.

Secure the system to prevent unintentional switching on again.

Route all low voltage cables (24VDC) separate from the power current cables. Design cable types, lengths, and cross sections in accordance with the technical information. Cable specifications is a guide only, the overall responsibility resides with the electrical contractor on site. Installation must be in accordance with the national electrical regulations.

2 Introduction to WCC 106 A

WCC 106 A is a MotorController that controls (opens/closes) 1 or more $\pm 24V$ standard or MotorLink® window actuators on the basis of a signal from the remote-control type WCA 100, the App "Fresh Air Control", connected comfort keypads or the connected components, e.g., room sensors and weather sensors.

2.1 The MotorController's construction

The MotorController contains a 150W primary power supply (SMPS - switched mode power supply) and a printed circuit board with input, output, and auxiliary supply (AUX).

WCC 106 A has 2 motor lines to which $\pm 24V$ standard actuators or MotorLink® actuators can be connected; the number of connected actuators depends on the actuator type; the following table lists the max number of actuators. Total power consumption for all connected motors incl. load on X7 (AUX max 0.5A) may not, however, exceed 6A.

2.2 MotorController variants

Item composing					
WCC 1	06	A		xx	xx
				<u>Version</u> 01 = version 1 02 = version 2, allows control via app	
				<u>Variants</u> 01 = Standard variant with Schuko plug 04 = UK variant with UK network adapter	
				<u>Communication</u> A = wireless operation via app or remote control	
				<u>MotorController size</u> 06 = 6A	
MotorController series 1					

2.3 Max number of actuators per MotorController

The table shows the maximum number of actuators which can be connected to the WCC 106 A. The total power consumption for all connected actuators incl. load on X7 (AUX max 0.5A) may not exceed 6A.

	Per motor line		Per MotorController	
	± 24V actuators	MotorLink® actuators	± 24V actuators	MotorLink® actuators (2 motor lines)
WMD 820-1	6	4	6	6
WMD 820-2	6	2	6	4
WMD 820-3	6	3	6	6
WMD 820-4	4	4	4	4
WMS 306 / 309-1	6	4	6	6
WMS 306 / 309-2	6	2	6	4
WMS 306 / 309-3	6	3	6	6
WMS 306 / 309-4	4	4	4	4
WMS 409 xxxx 01	3	0	3	0
WMS 409-1	3	3	3	3
WMS 409-2	2	2	2	2
WMS 409-3	3	3	3	3
WMU 831 / 851-1	6	4	6	6
WMU 831 / 851-2	6	2	6	4
WMU 831 / 851-3	6	3	6	6
WMU 831 / 851-4	4	4	4	4
WMU 836-1	4	4	4	4
WMU 836-2	4	2	4	4
WMU 836-3	3	3	3	3
WMU 836-4	4	4	4	4
WMU 852-1	3	3	3	3
WM 852-2	2	2	2	2
WMU 852-3	3	3	3	3
WMU 861-1	2	2	2	2
WMU 861-2	4	2	4	4
WMU 861-3	3	3	3	3
WMU 842 / 862 / 882-1	2	2	2	2
WMU 842 / 862 / 882-2	2	2	2	2
WMU 863 / 883-1	2	2	2	2
WMU 863 / 883-2	2	2	2	2
WMU 864 / 884-1	1	1	1	1
WMU 885 / 895-1	1	1	1	1

	Per motor line		Per MotorController	
	± 24V actuators	MotorLink® actuators	± 24V actuators	MotorLink® actuators (2 motor lines)
WMX 503 / 504 / 523 / 526-1	10	4	10	8
WMX 503 / 504 / 523 / 526-2	10	2	10	4
WMX 503 / 504 / 523 / 526-3	9	3	9	6
WMX 503 / 504 / 523 / 526-4	8	4	8	8
WMX 803 / 804 / 813 / 814 / 823 / 826-1	6	4	6	6
WMX 803 / 804 / 813 / 814 / 823 / 826-2	6	2	6	4
WMX 803 / 804 / 813 / 814 / 823 / 826-3	6	3	6	6
WMX 803 / 804 / 813 / 814 / 823 / 826-4	4	4	4	4
WML 820/825	6	0	6	0
WML 860-1	6	4	6	6
WML 860-2	6	2	6	4
WML 860-3	6	3	6	6
WML 860-4	4	4	4	4
WMB 801/802*	max. 4A connected to the WMB			
WMB 811/812/815/816/817/818 */***	6	2	6	2

*do not exceed the total power consumption of the motor line

**with 2 locking actuators on the same motor line use: 1 x WMB 811 and 1 x WMB 812, 1 x WMB 815 and 1 x WMB 816 or 1 x WMB 817 and 1 x WMB 818

3 Accessories

Accessories	
Rain sensor	WLA 331
Rain / windspeed sensor	WLA 330
Comfort keypad, 1 window or 1 window group	WSK 110 0A0B
Comfort keypad, 2 windows or 2 window groups	WSK 120 0A0B 0A0B
Comfort keypad, model FUGA, surface mounting (CH version)	WSK 300
Comfort keypad, model FUGA, surface mounting	WSK 103
Room thermostat: temperature	WLA 110

4 Technical data

Technical data	
Output current	6A incl. load on X7 (max 0.5A)
Secondary voltage	Voltage 24V DC (±15%) Resting potential with 230V AC without load 24V DC @ 20°C Ripple with full load 200mVp-p
AUX	24V DC, 500mA
Motor groups / Motor lines	Up to 2 motor groups with each 1 motor line Either ±24V standard actuators or MotorLink® actuators can be connected to the MotorController
Primary voltage	MotorController: 100-240 VAC 1.7A 50/60Hz
Power consumption	Idling < 0.5W Full load 150W
Leakage current	Max 0.75mA @ 240VAC
Inrush current on primary side	60A < 5ms w. 230V Max. 3 x WCC 106 A per 10A power supply group. Circuit breaker "C" type.
±24V	Min. 500ms

LED signalling	3 green LEDs and 1 yellow indicate via blinking sequences failure and/or status of the system and motor line. See paragraph on “Status and troubleshooting via LED on the MotorController” for a detailed description and blinking sequences.	
Connection cable	Actuators	flexible max. 6mm ² / solid max. 10 mm ²
	Other components	min 0.2mm ² / max. 1.5mm ²
Operation range between MotorController and remote control	<ul style="list-style-type: none"> - Outside: up to 50m in radius - Inside: up to 10m in radius Physical barriers such as walls, cabinets etc. will reduce the range.	
Operating conditions	-5°C - +45°C, for indoor mounting, the MotorController must not be covered	
Max actuator activation duration (duty cycle)	ED 40% (4 min. per 10 min.)	
Material	Plastic	
Colour	White (RAL 9016)	
Size	MotorController: 215 x 206 x 37mm (W x H x D)	
Weight	MotorController: 0.92kg	
Protection class	IP 20	
Safety class	I (with PE)	
Delivery	Standard version:	MotorController with 1.2 m cable with Schuko plug
	UK version:	MotorController with 1.2 m cable with Schuko plug and UK network adapter
Note	We reserve the right to make technical changes	

5 Mounting

The MotorController may either be mounted horizontally or vertically on a wall.

The MotorController is fixed to the wall through the back plate's Ø4.5 mm mounting holes.

The MotorController should be mounted in a secure location so that it is protected against the effects of fire and smoke.

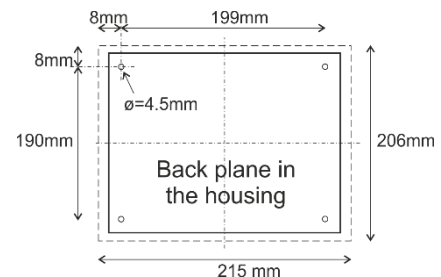

6 Installation

6.1 Cable routing

The safety regulations in these guidelines must be closely followed. Regarding low power cable configuration we refer you to the chapter “Cable dimensioning”. The cable cross sections listed in the table of cable lengths must not be reduced.

The cables are led into the MotorController’s cabinet via cut-outs in the bottom. When routing cables, all applicable national regulations must be complied with. The MotorController is supplied with a 1.2 m cable with Schuko plug.

6.2 Connecting cables in the MotorController

Cables are to be connected in accordance with the chapter “Connection plan for WCC 106 A”, the short chapters and other relevant paragraphs in these guidelines.

Please ensure that connections are correctly executed - incorrect connection can lead to functional failure in the MotorController or external products.

The installation must at all times adhere to the applicable regulations, standards and guidelines.

6.3 Connecting protective earth and 230V AC

WCC 106 A is factory-fitted with a power supply cable with a 230V Schuko plug with earth wire.

6.4 Installation of comfort keypad

Any comfort keypad should be mounted in a visible position and within easy reach.

6.5 Assembly instructions

Always have assembly, installation, repair and maintenance of ventilation systems carried out by qualified personnel trained for this purpose.

Rules to be adhered to for setting up and installation

The following safety relevant rules have to be adhered to when planning the use of a ventilation system and its set-up and installation:

- The Provincial Building Ordinance of the provinces

Accident prevention regulations Adhere to the general accident prevention regulations (APR), the APR for power operated windows and doors, and the installation rules in your country.

Caution:

If internal coverings are removed the live current parts are exposed.

Guidelines for mounting / installation

- the MotorController should be mounted on the wall in such a way that there is free access for service inspections
- adhere to the installation instructions and your local energy providers
- select the place of installation such that free access is guaranteed for maintenance purposes
- select cables according to regulations in this instruction - take the calculation of the actuators supply cable lengths into account when laying the cables
- connect the cables in accordance with the drawings provided by the manufacturer
- route the cables in the building according to the regulations in this instruction
- check all system functions

7 Cable dimensioning

Cables should be routed in compliance with applicable regulations.

7.1 Max. cable length

The maximum permitted cable lengths from the MotorController to the actuators, taking into account the cable cross-section, are shown in the following table.

7.1.1 Formula for calculating max. actuator cable length

Max. cable length = $\frac{\text{permitted voltage drop } 2V \text{ (UL)} \times \text{copper's conductivity } (56) \times \text{cable cross-section in mm}^2 \text{ (a)}}{\text{Max. total actuator current per motor line in amperes (I)} \times 2}$

For ±24V standard actuators, the cable cross-section may not be less than 0.75 mm², irrespective of the result of the above formula.

Maximum actuator cable length: Always measured from the MotorController to the last junction box + actuator cable

Permissible max. voltage drop in the line: 2 Volt

Total actuator current: The sum of all the connected actuators max. current consumption per motor line

Note: do not use the PE wire / green/yellow wire in the actuator cable!

Example

Max. actuator cable length with cable cross-section of 0.75mm² and 2A current consumption: $(2 \times 56 \times 0.75) : (2 \times 2) = \underline{21m}$

7.1.2 Max. cable length – ±24V standard actuators

The actuator cable must have 2 wires minimum.

±24V standard actuators						
The PE wire/the green-yellow earth wire must <u>not</u> be used						
Cable-cross-section [a]	3-wire 0.75mm ²	3-wire 1.50 mm ²	5-wire 1.50 mm ² 2-wire parallel	3-wire 2.50 mm ²	5-wire 2.50 mm ² 2-wire parallel	3-wire 4.00 mm ²
Total actuator current [I]						
1A	42m	84m	168m	140m	280m	224m
2A	21m	42m	84m	70m	140m	112m
3A	14m	28m	56m	47m	93m	75m
4A	11m	21m	42m	35m	70m	56m
5A	8m	17m	34m	28m	56m	45m
6A	7m	14m	28m	23m	47m	37m

7.1.3 Max cable length – actuators with MotorLink®

The actuator supply cable must have 3 wires: 2 wires current carrying / 1 wire for communication.

When a 5-wire cable is used for MotorLink®

It is not recommended to use parallel-wire.

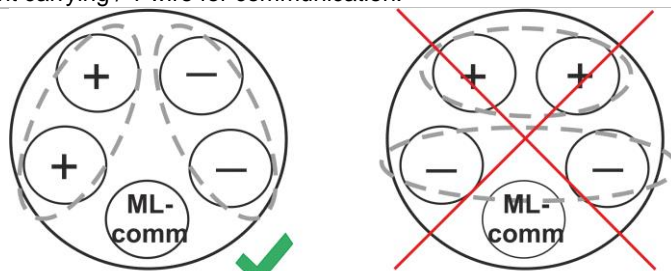

ML-comm = MotorLink® communication.

Furthermore, when using a 5-core cable, the distance between "-" and "Com" must be the same as the distance between "+" and "Com".

Meaning if L2 e.g. is being used as "Com" L1 and L3 must be used for "+" and "-".

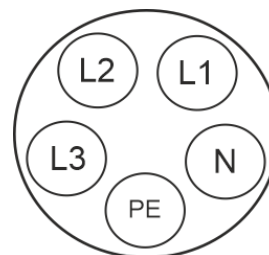

When using actuators with MotorLink® the max/total cable length is 50m regardless of the result of the above mentioned formula.

Actuators with MotorLink®						
Do not use the PE wire / green/yellow wire!						
cable cross section [a]	3 wire 0.75mm ²	3 wire 1.50 mm ²	5 wire 1.50 mm ² 2 wire parallel	3 wire 2.50 mm ²	5 wire 2.50 mm ² 2 wire parallel	3 wire 4.00 mm ²
Total actuator current [I]						
1A	42m	50m				
2A	21m	40m	50m			
3A	14m	28m	50m	47m	50m	
4A	11m	21m	42m	35m	50m	
5A	8m	17m	34m	28m	50m	45m
6A	7m	14m	28m	23m	47m	37m

Definition of total cable length

The total cable length is defined as the sum of all cables from the MotorController output to the last actuator. Including the cable mounted on the actuator.

For example, in case of 4 actuators with 5m cable each, the remaining cable length is 30m.

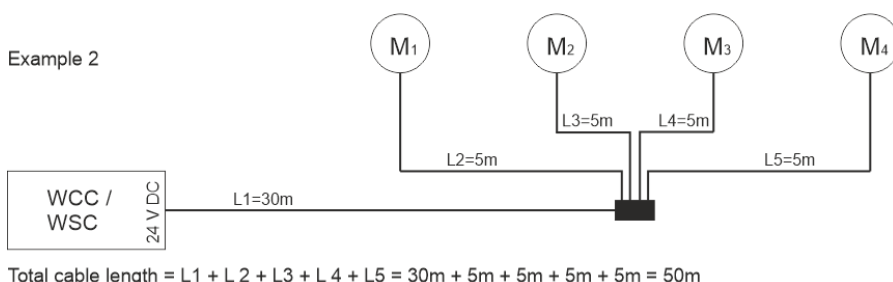
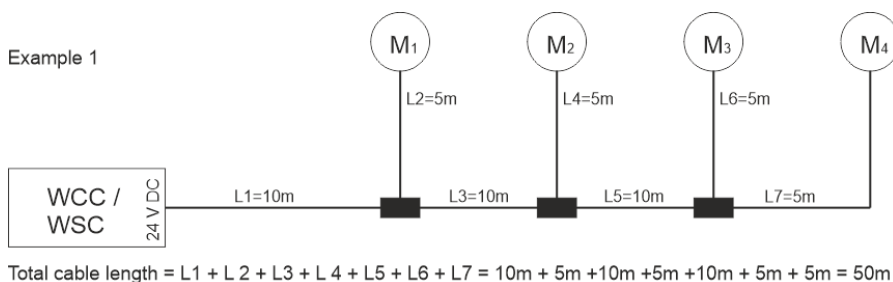

8 Connection plan for WCC 106 A

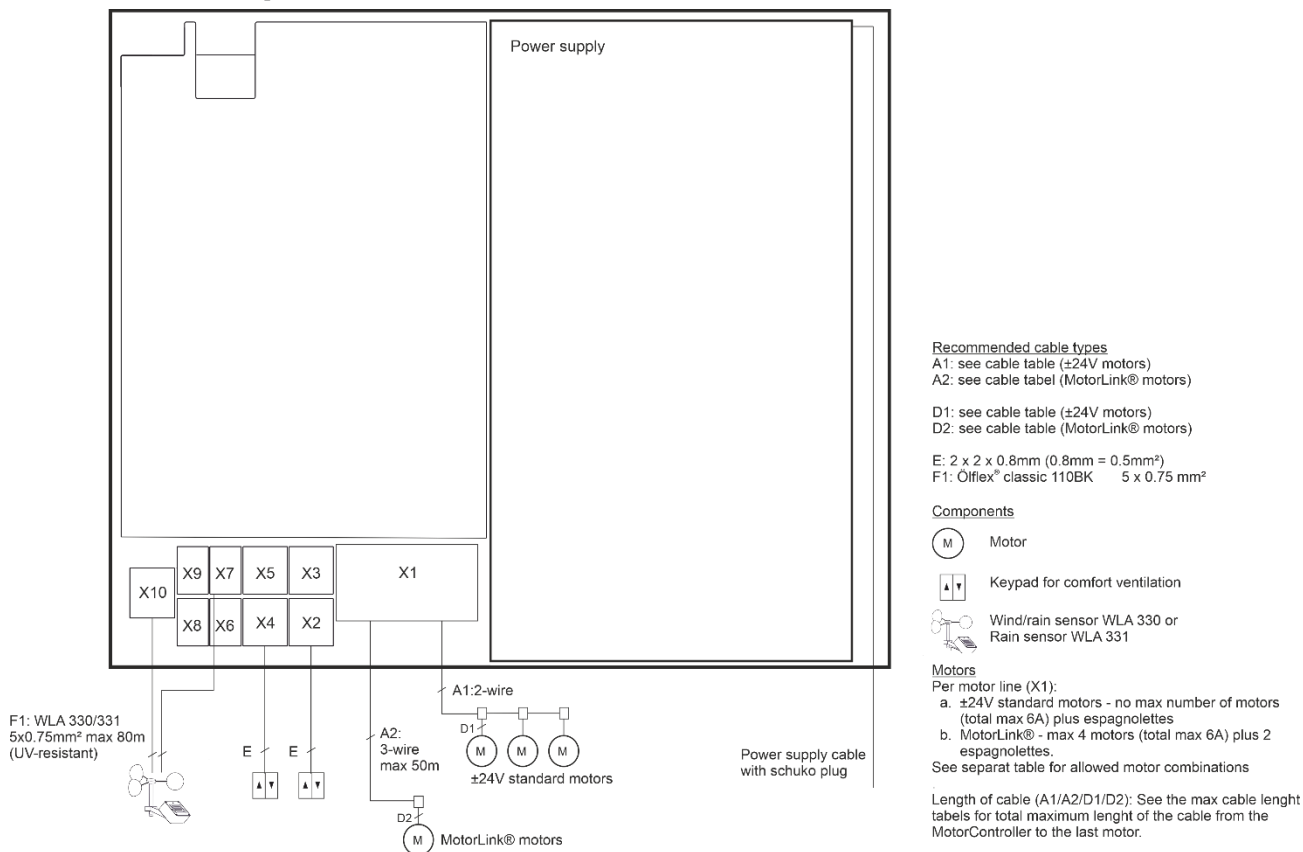

The above connection plan shows a WCC 106 A MotorController

9 Connection description

On the WCC 106 A the following can be connected: ±24V standard actuators, MotorLink® actuators, comfort keypad, thermostat and similar plus wind / rain sensor.

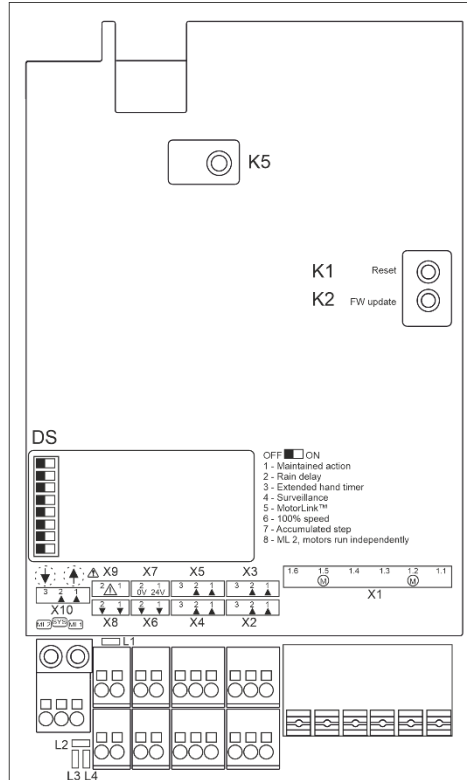

- | | |
|------------------------------------------------------------------------------------------------------------------------------------------------------------------------------------------------------------------------------------------------------------------------------------------------------------------------------------------------------------------------------------------------------------------------------------------------------------------------------------------------------------------------------------------------------------------------------------------------------------------------------------------------------------------------------------------------------------------------------------------------------------------------------------------------------------------------------------------|------------------------------------------------------------------------------------------------------------------------------------------------------------------------------------------------------------------------------------------------------------------------------------------------------------------------------------------------------------------------------------------------------------------------------------------------------------------------------------------------------------------------|
| <p>X1 1.1 24V / 0V } Motor line #1
 1.2 MotorLink®
 1.3 0V / 24V</p> <p>1.4 24V / 0V } Motor line #2
 1.5 MotorLink®
 1.6 0V / 24V</p> <p>X2 2.1 Open } Comfort keypad #1
 2.2 Close
 2.3 GND / 0V</p> <p>X3 3.1 Open } Automatic control #1
 3.2 Close
 3.3 GND / 0V</p> <p>X4 4.1 Open } Comfort keypad #2
 4.2 Close
 4.3 GND / 0V</p> <p>X5 5.1 Open } Automatic control #2
 5.2 Close
 5.3 GND / 0V</p> <p>X6 6.1 Output #1 } Status (open)
 6.2 Output #1</p> <p>X7 7.1 24V } AUX, power supply for external sensor
 7.2 0V</p> <p>X8 8.1 Output #2 } Status (open)
 8.2 Output #2</p> | <p>X9 9.1 Fault } Output
 9.2 Fault</p> <p>X10 10.1 Common open
 10.2 Common close (Rain) } Common /
 10.3 GND / 0V } Weather station</p> <p>DS DIP switch 1-8</p> <p>↓ ↑ Close and open all windows</p> <p>K1 Reset</p> <p>K2 Firmware update</p> <p>K5 Pairing</p> <p>L1 LED 1 - Sum error</p> <p>L2 LED 2 - System status</p> <p>L3 LED 3 - Motorline #2 status</p> <p>L4 LED 4 - Motorline #1 status</p> |
|------------------------------------------------------------------------------------------------------------------------------------------------------------------------------------------------------------------------------------------------------------------------------------------------------------------------------------------------------------------------------------------------------------------------------------------------------------------------------------------------------------------------------------------------------------------------------------------------------------------------------------------------------------------------------------------------------------------------------------------------------------------------------------------------------------------------------------------|------------------------------------------------------------------------------------------------------------------------------------------------------------------------------------------------------------------------------------------------------------------------------------------------------------------------------------------------------------------------------------------------------------------------------------------------------------------------------------------------------------------------|

X1 WCC 106 A contains two motor lines to which ±24V standard actuators or MotorLink® actuators can be connected. The two motor lines must run with the same type of actuators, meaning either ±24V standard actuators or MotorLink® actuators. When running MotorLink® actuators, DIP switch #5 must be set, see chapter about DIP switches for details.

±24V standard actuators

- Data:
- | | |
|--------------|-----------------|
| 1.1 24V / 0V | } motor line #1 |
| 1.2 | |
| 1.3 0V / 24V | |
| 1.4 24V / 0V | } motor line #2 |
| 1.5 | |
| 1.6 0V / 24V | |

MotorLink® actuators

- Data:
- | | |
|-------------------|-----------------|
| 1.1 0V | } motor line #1 |
| 1.2 Communication | |
| 1.3 24V | |
| 1.4 0V | } motor line #2 |
| 1.5 Communication | |
| 1.6 24V | |

The number of permitted actuators on the motor line depends on the actuator type. The total current consumption connected to the motor line may not exceed 6A and the total current consumption for both motor lines may not exceed 6A incl. load on X7 (AUX). In addition to the actuators, locking actuators of type WMB 8xx

may also be connected. The locking actuators' power consumption is not included in the calculated 6A as the actuators and locking actuators do not run simultaneously.

All actuators on the same motor line run/are operated at the same time.
All actuators on a motor line must be the same type.

Connection / cable diameter: flexible max 6 mm² / solid max 10 mm².
Cable length: see the chapter "Cable dimensioning".

Standard ±24V actuators

Example with max. 3A current consumption

- a) 3 pcs. WMX 826-1
- b) 2 sets of 3 pcs. WMX 504-3
- c) 1 pc. WMU 883-1
- d) 2 pcs. WMU 861-2

Connecting variants to standard actuators on motor line 1

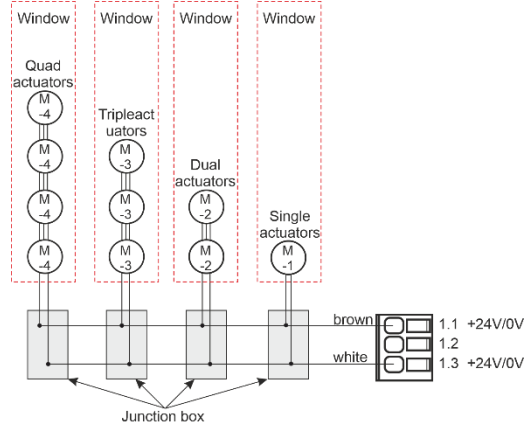

MotorLink® actuators

Examples with actuators per motor line

- Ex. 1: 4 pcs. WMX 823-1
- Ex. 2: 2 pcs. WMX 836-2
- Ex. 3: 3 pcs. WMU 826-3

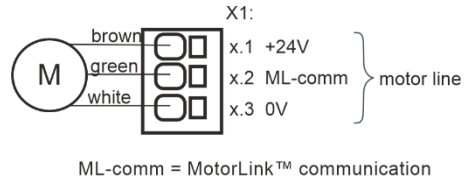

Allowed actuator combinations on a MotorLink® motor line

The two motor lines can each be connected to one of the below shown combinations.

- 1 (single): one window with one single window actuator. Up to four windows each with one single window actuator can be connected
- 2 (double): one window with two double window actuators.
- 3 (triple): one window with three triple window actuators.
- 4 (quad): one window with four quad window actuators.

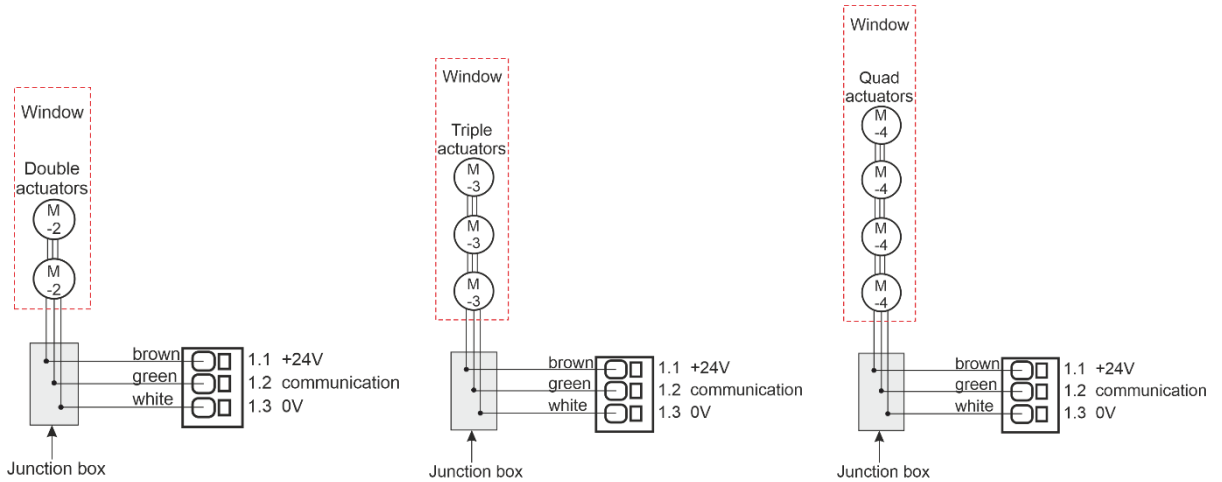
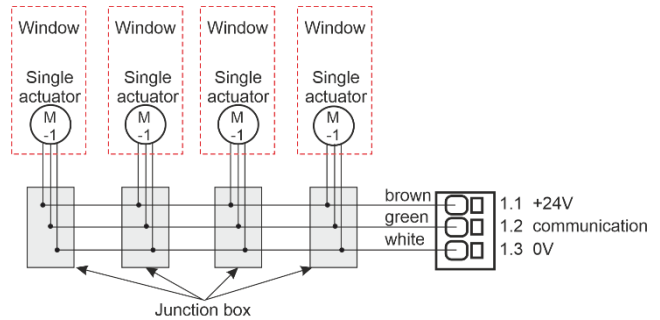

X2 / X4

Input for connection of comfort keypad

Motor line 1:

Data:

- 2.1 Open
- 2.2 Close
- 2.3 GND / 0V

Motor line 2:

Data:

- 4.1 Open
- 4.2 Close
- 4.3 GND / 0V

With the factory-set values the input is:

"Active" if resistor is less than 5k Ω "Inactive" if resistor is greater than 8k Ω .

Input has pull-up current of approx. 1mA (min. 0.9mA, max. 1.1mA) if input short-circuits.

Example: Comfort keypad connected to input X2

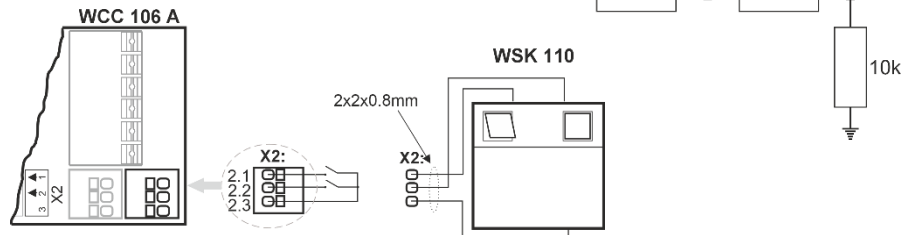

Long press (>500ms): open/close actuator, actuator runs to end stop

Short press: actuator stops running

X3 / X5

Input for automatic control.

Motor line 1:

Data:

- 3.1 Open
- 3.2 Close
- 3.3 GND / 0V

Motor line 2:

Data:

- 5.1 Open
- 5.2 Close
- 5.3 GND / 0V

X3 and X5 must be controlled by potential/volt free contact.

X3 and X5 have lower priority than X2 and X4 respectively.

X3 and X5 are blocked for 30 minutes after X2 and X4 respectively has received a command (from production code 11BM03KW).

X6 / X8

Motor line status (open) possibility to connect to BMS

Solid state relay output. Output is off (infinite resistance) when windows are assumed closed.

Motor line 1:

Data:

- 6.1 Output
- 6.2 Output

Motor line 2:

Data:

- 8.1 Output
- 8.2 Output

Solid state output for signal transmission.

Data

Max. voltage: 30 Vp (peak)

Max. current: 150 mA

Typical On-resistor: 15 Ω Max. On- resistor: 18 Ω

Max. Switching speed: 2 ms

Output circuit (simplified)

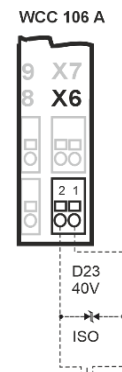

Example with solid state and relay (polarization is not important)

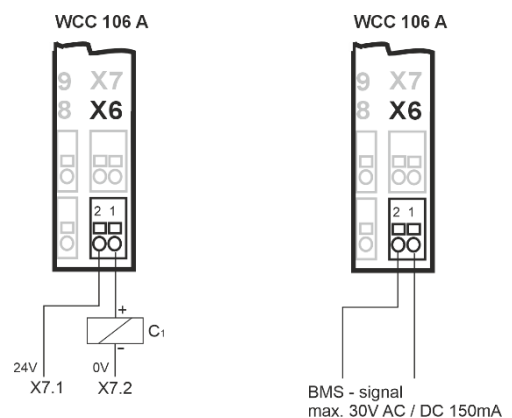

X7

AUX, power supply for weather station, for example. See "X10" for a description of connection of rain/wind sensors.

Data:
7.1 24V
7.2 0V

Maximum 500 mA

Main power must be switched off, before connecting any kind of external equipment to X7!
Connected consumption must be included in the controller's total load, which must not exceed 6A.

X9

Solid state output, for transmission of fault signal

Data:
9.1 Fault – Open contact = Fault, Closed contact = OK
9.2 Fault – Open contact = Fault, Closed contact = OK

Data
Max. voltage: 30 Vp (peak)
Max. current: 150 mA
Typical On- resistance: 15Ω
Max. On-resistance: 18 Ω
Max. switching speed: 2 ms

X10

Connecting wind / rain sensors of type WLA 330 or WLA 331.
Wind / rain sensor must be connected on both X10 and X7.

Data:
10.1 Common Open
10.2 Common Close (Rain)
10.3 GND / 0V

X10 has highest priority over X2/X4 and X3/X5.

With the factory-set values the input is:
"Active" if resistor is less than 5kΩ
"Inactive" if resistor is greater than 8kΩ.

Input has pull-up of approx. 1mA (min. 0.9mA, max. 1.1mA)

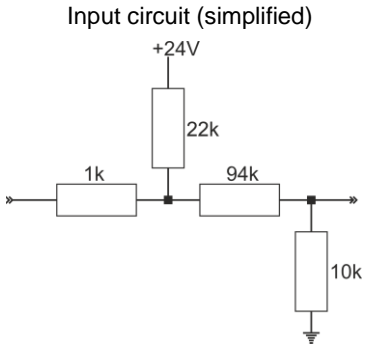

Connecting wind/rain and rain sensor

WLA 330 and WLA 331– the sensors settings are set on the sensor.

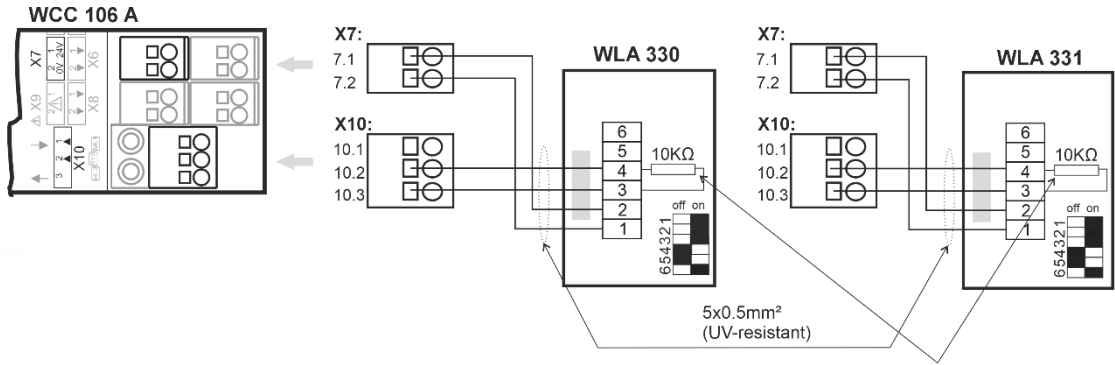

DIP switches 1-3 on WLA 330 must be set in relation to windspeed tolerances. See the guideline for WLA 330 for DIP switch settings.

DS	DIP switch block with 8 DIP switches. 1 Maintained action 2 Rain delay 3 Extended hand timer 4 Surveillance 5 MotorLink® 6 100% speed 7 Accumulated step 8 Motor line 2, motors run independently Factory setting = OFF See chapter "DIP switch configuration" for detail information.
↓ ↑	Close / Open all windows
K1	Reset
K2	FW update; to be used in line with firmware updates
K5	Pairing, used when the MotorController is to be paired with the remote control type WCA 100
LED 1	Yellow LED that indicates error on the MotorController. As a reference to fault output X9. If the diode is off, there is no error/failure. Output X9 is OFF. See chapter, "Status and troubleshooting via LED on the MotorController" for more information.
LED 2	Green LED that shows status of MotorController. If diode lights constantly, there is no error/failure. If the diode blinks, see chapter, "Status and troubleshooting via LED on the MotorController" for more information.
LED 3	Green LED that shows status of the motor line 2. The diode can light constantly or blink asynchronously. See chapter, "Status and troubleshooting via LED on the MotorController" for more information.
LED 4	Green LED that shows status of the motor line 1. The diode can light constantly or blink asynchronously. See chapter, "Status and troubleshooting via LED on the MotorController" for more information.

10 DIP switch configuration

The MotorController has 8 DIP switches for easy configuration. The factory setting for the DIP switches is OFF.

DIP switch	Description on the MotorControlleren	DIP switch position
1	Maintained action	ON: the actuators open/close completely when the comfort keypad is pressed. OFF: the actuators run for as long as the comfort keypad is being pressed.
2	Rain delay	ON: the rain signal must be active min. 60 sec. before the actuators begin to close. OFF: the actuators begin to close as soon as the rain signal is activated.
3	Extended hand timer	ON: after manuel override the actuators are locked for 2 hours (except rain/safety signals). OFF: after manuel override the actuators are locked for 30min (except rain/safety signals).
4	Surveillance	ON: activate cable surveillance on input X10.1 (rain). The Input must be terminated with 10k resistor. OFF: no cable surveillance.
5	MotorLink®	ON: MotorLink® motors are connected to the MotorController. It might be necessary to reset the MotorController when activating this DIP switch. OFF: ±24V standard motors are connected to the MotorController.
6	100% speed	ON: actuators run with 100% speed, when run manually. (this setting requires MotorLink® actuators and that DIP switch 5 is set to "ON") OFF: actuators run with 75% speed, when run manually.
7	Accumulated step	ON: actuators open/close in steps, when a thermostat e.g., WLA 110 is connected to the MotorController and the setpoint is exceeded. Opening step: 5% for every 5min Closing step: 10% for every 10min OFF: actuators open/close completely when a thermostat e.g., WLA 110 is connected to the MotorController and the setpoint is exceeded

DIP switch	Description on the MotorControlleren	DIP switch position
8	ML 2, motors run independently	<p>ON: the actuators on motor line 2 are controlled individually via input X2, X3, X4 and X5. Up to 4 actuators can be connected to motor line 2 and all actuators must be single / -1 actuators. The actuator's serial number determines, which input controls which actuator, the serial number is automatically identified by the firmware in the MotorController. X2 – controls the actuator with the highest serial number X3 – controls the actuator with the second-highest serial number X4 – controls the actuator with the second-lowest serial number X5 – controls the actuator with the lowest serial number</p> <p>The actuators can be identified by activating the different inputs. The serial number can also be read on the product label on the actuator.</p> <p>Actuators on motor line 1 are controlled together via input X10. Up to 4 actuators can be connected to motor line 1. All actuators on motor line 1 must be of the same type, incl. team size and chain length. The actuators must be either single /-1 or quad /-4.</p> <p>All connected actuators on both motor lines must be MotorLink® actuators and DIP switch #5 must also be set to ON.</p> <p>This DIP switch setting does not influence how the actuators on the two motor lines are controlled via the remote control. (this setting requires MotorLink® actuators and that DIP switch 5 is set to "ON")</p> <p>OFF: 2 Motor groups with a motor line each</p>

11 Control via remote control – WCA 100









The window actuators connected to the MotorController can be controlled (opening and closing) with the remote control type WCA 100.

The remote control has an operation range up to 50m outside and 10m inside.
Physical barriers such as walls, cabinets etc. will reduce the operation range.



The remote control has 3 buttons, each with 3 keys (functions) – OPEN, STOP and CLOSE.

Button and key functions on the remote control

<div style="display: flex; flex-direction: column; align-items: center;"> <div style="display: flex; gap: 10px;"> <div style="border: 1px solid gray; padding: 2px;">#1</div> <div style="border: 1px solid gray; padding: 2px;">#4</div> <div style="border: 1px solid gray; padding: 2px;">#7</div> </div> <div style="display: flex; gap: 10px;"> <div style="border: 1px solid gray; padding: 2px;">#2</div> <div style="border: 1px solid gray; padding: 2px;">#5</div> <div style="border: 1px solid gray; padding: 2px;">#8</div> </div> <div style="display: flex; gap: 10px;"> <div style="border: 1px solid gray; padding: 2px;">#3</div> <div style="border: 1px solid gray; padding: 2px;">#6</div> <div style="border: 1px solid gray; padding: 2px;">#9</div> </div> <p>Button and key function overview</p> </div>	Key number Function	 #1 Actuators connected to ML #1 open	 #4 Actuators connected to ML #1 stop	 #7 Actuators connected to ML #1 close
	Key number Function	 #2 Actuators connected to ML #2 open	 #5 Actuators connected to ML #2 stop	 #8 Actuators connected to ML #2 close
	Key number Function	 #3 All actuators connected to WCC 106 A open	 #6 All actuators connected to WCC 106 A stop	 #9 All actuators connected to WCC 106 A close

ML = motor line

A short blink on the remote control's green LED indicates that the command from the remote control to the MotorController has been received by the MotorController.

A short blink on the remote control's red LED indicates that the command from the remote control to the MotorController has not been received by the MotorController.

11.1 Before use

The remote control is supplied with 2 x AAA batteries, which must be inserted before use.

Furthermore, the remote control and the MotorController must be paired with each other before the remote control can operate the actuators connected to the MotorController.

11.1.1 Pairing of remote control and MotorController

To avoid any disturbances the remote control must be held close to the MotorController during pairing. Only activate pairing mode on one MotorController at the time, otherwise, the remote control will pair with the MotorController with the strongest signal.

A remote control can only be paired with one MotorController.

MotorController

1. Activate pairing mode on MotorControlleren by pressing K5 (pairing button) on the MotorControlleren.

Remote control

The remote control differs between two different presses; a short and a long press.

The short press is used for normal/daily operation, meaning control of the window actuators. The long press is used for the pairing process.

Short press: the press lasts max. 3 sec.

Long press: the press lasts min. 3 sec.

1. Activate pairing mode on the remote control, by pressing simultaneously on key #3 and #9 – see above "Button and key function overview". The press must be a long press on both keys meaning min. 3 sec.
When the remote control is in pairing mode it starts blinking first red and then green double blinks.
2. As the remote control only can be paired with one MotorController, the remote control automatically deletes any previously paired MotorControllers before it starts the pairing process with the desired MotorController.
3. The remote control starts a scanning process to identify the desired MotorController, which also must be the one closest to the remote control.
On the remote control, the scanning is indicated by the green LED, which every second blinks two short blinks.
4. a) The LED on the remote control blinks one long green blink. The pairing process was a success, the remote control and the MotorController is now paired.
b) The LED on the remote control blinks one long red blink. The pairing process failed.

The pairing process succeeded:

The MotorController and remote control are now ready for use. Carry out a test run, if this is the MotorController's first pairing, see chapter "Commissioning and test run".

The pairing process failed:

- Ensure that the batteries are inserted correctly into the remote control.
- Ensure that the MotorController has been connected to 230V and that pairing mode is activated.
- Ensure that MotorController and remote control – during the pairing process – are close to each other and that there are no disturbances between them, such as walls, furniture etc.
- Replace the batteries in the remote control.
- Repeat the pairing process.

If the pairing process continues to fail please contact your local WindowMaster office.

12 Control via app – Fresh Air Control

The windows can also be controlled via app. The MotorController must be version 02 or higher for the app to be used.

The app "Fresh Air Control" can be downloaded from Google Play or App Store.

The app can connect to several MotorControllers. WindowMaster recommends connecting max. 5 MotorControllers to a smartphone/tablet and max. 5 smartphones/ tablets to a MotorController.

13 Status and troubleshooting via LED on the MotorController

In the event of failure/error of the MotorController one or more diodes will light and/or blink.

On the WCC 106 A there are 4 diodes - 3 green and 1 yellow - that can indicate errors and status on the MotorController.

Irrespective which diode lights or blinks, the indicator is based on a 3.2 second sequence that is repeated continuously. Each sequence is defined by 32 x 0.1 second time segments.

If there are several errors on the MotorController simultaneously they are displayed by priority, i.e. error messages for the most critical failures are shown first and repeated until the failure is remedied. Then error number two is shown, which likewise is repeated until the error is remedied etc. The following overview shows the most frequently occurring errors, if an error other than those listed below is indicated, contact WindowMaster.

Yellow diode – LED 1

If the yellow diode lights, this indicates an error on the MotorController.
 Black = diode off



Error indicator on the yellow diode is a total errors indicator. Detailed information on the error type can be decoded on the green diode.

Green diode – LED 2

If the green diode LED 2 (closest to X10) blinks, this indicates the error on the MotorController.
 Black = diode off

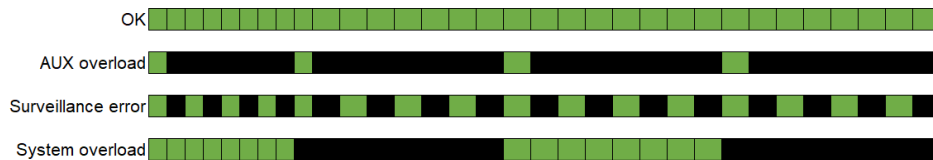

Green diode – LED 3

The green diode LED 3 (furthest away from X8) indicates status of or error on the motor line #2.
 Black = diode off

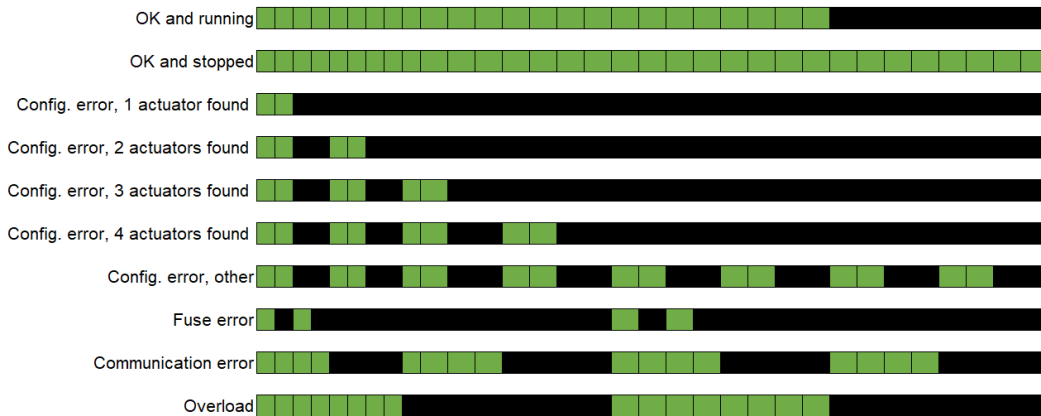

Green diode – LED 4

The green diode LED 4 (closest to X8) indicates status of or error on the motor line #1.
 Black = diode off

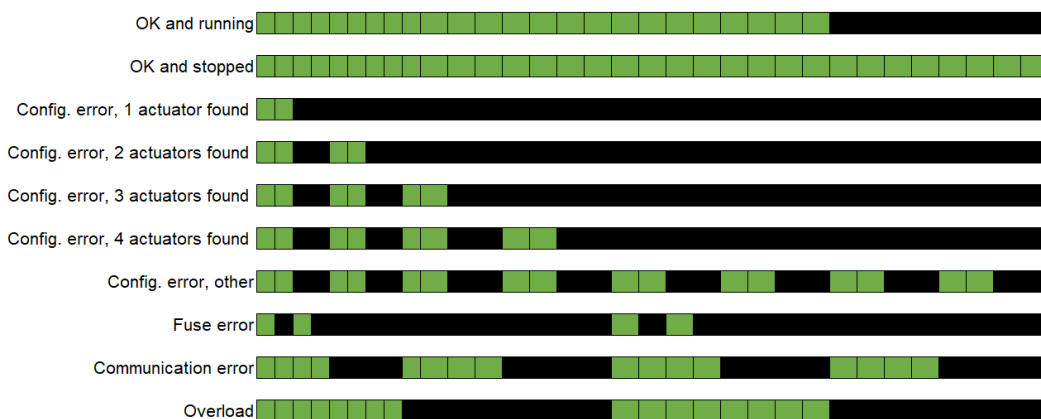

14 Commissioning and test run

In the event of error messages, refer to chapter “Status and troubleshooting via LED on the MotorController”.

14.1 MotorController fully installed, without operating power

1. Check all mechanical and electrical components for damage.
2. Check all screw and plug connections for tightness and/or firm seating.
3. Check that all external components are installed; check polarity for the ±24V actuators

14.2 With network power

Adhere to the relevant regulations!

Connect the mains cables and reapply the mains voltage.

14.3 Remote control and comfort keypad

Look closely at the actuators as they open and close - there must not be any obstacles in any position and the actuator connection wires must not be overstrained with pulling or pinching.

Test the remote control and every single comfort keypad if installed.

14.4 Wind/rain sensor

1. Open the actuators with the comfort keypads.
2. Dampen the rain sensor, the actuators close completely.
3. While the actuators are running, press Open button on the comfort keypad. The actuators must neither open nor stop.

If commissioning proceeds correctly, the lid of the MotorController may be fitted.

If commissioning does not proceed correctly, i.e. there is an error in one of the test points, refer to chapter "Connection description" if necessary, re-test the cable routing in accordance with chapter "Connection plan for WCC 106 A".

15 Maintenance

Control and maintenance should only be done by the manufacturer or an authorized partner.

Remove all soiling from the MotorController. Check fastening and clamping screws for firm seating.

Carry out a test run of the entire system (see chapter 19 'Commissioning and test run').

Only have defective units repaired in our factory. Only install original spare parts.

The expected minimum lifetime for the MotorController is 10 years.

15.1 Maintenance agreement

WindowMaster offers a maintenance agreement for MotorController. Contact our service department for further information:

Tel. +44 1536 614 070 or info.uk@windowmaster.com

16 Components declaration

The MotorController has been produced and tested in compliance with European guidelines.

The "Declaration of Conformity" is supplied with the MotorController as a separate document.