



## WMS 309 Spindle actuator 900N



Natural  
ventilation

24V

±24V control

6.15

### Description

- for comfort ventilation
- strong actuator suitable for roof openings
- to be used together with  $\pm 24V$  control units
- soft close function
- automatically switches off when it reaches its end positions due to the built-in electronic load switch-off.
- electronic actuator with micro controller
- the actuator has an integrated reverse function to ensure a prolonged life span of the window gaskets
- easy mounting
- maintenance free through permanent lubrication
- outer parts corrosion-free
- heat resistant silicone connection cable

Technical specifications	
Pressure / Tractive force	900N / 900N
Locking force	2800N
Spindle length	300, 500, 750 and 1000mm
Opening speed	5.8mm/s (full load)
Nominal voltage	24V DC (max. 10% ripple)
Voltage	19 - 29 VDC
Open circuit voltage	Max. 32V DC
Current consumption	Max. 1A
Consumption of energy	Max. 24W
Operating conditions	-5°C - +74°C max. 90% relative humidity (not condensing)
Switch on duration	ED 30% (max. 3min. per 10min.)
Material	Aluminium tube
Colour	Natural anodised (EV1), other RAL-colours at additional cost
Size	ø36mm, length depending on spindle stroke – see table
Connection cable	5m grey connection cable in silicon 3-core 0.75mm <sup>2</sup> ø7.0mm
Weight	See table
IP rating	IP54 according to EN 50529
Delivery includes	Actuator with 5m connection cable
Note	We reserve the right to make technical changes

Stroke [mm]	Length (L) [mm]	Weight [kg]	Item no.
300	671	1.7	WMS 309 0300
500	871	2.1	WMS 309 0500
750	1121	2.5	WMS 309 0750
1000	1371	3.1	WMS 309 1000

Brackets	Item no.
Actuator bracket with clamping ring – 40mm	WSB 300 0001
Actuator bracket with clamping ring – 73 / 86mm	WSB 300 0002
Actuator bracket with clamping ring – 65mm	WSB 300 0003
Bottom screw	WSB 300 0004
Bracket with bolt and retaining cotter pin	WSB 300 0010
Bracket with fixing bolt	WSB 300 0011
Bracket with pin and retaining bracket	WSB 300 0012
<b>See separate product sheets for further information.</b>	

Installation suggestion 1

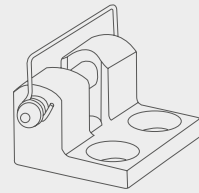
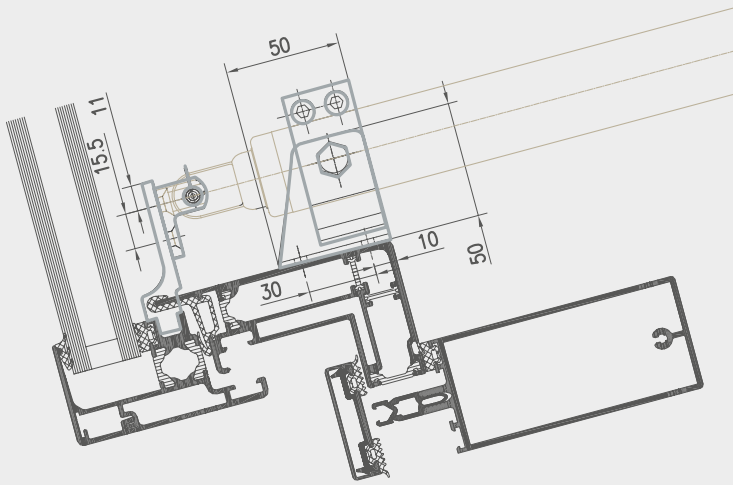

WSB 300 0012

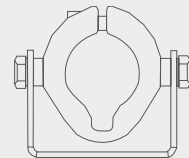

WSB 300 0001

Installation suggestion 2

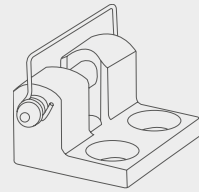
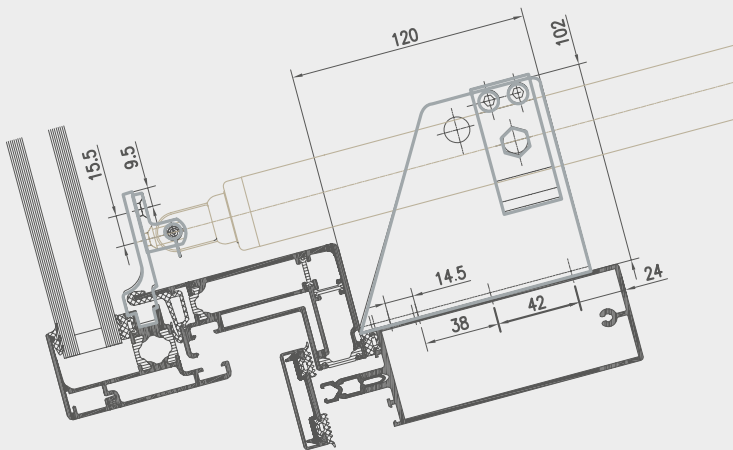

WSB 300 0012

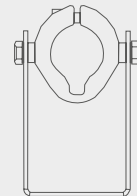

WSB 300 0002

Installation suggestion 3

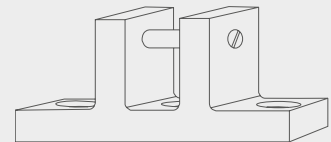
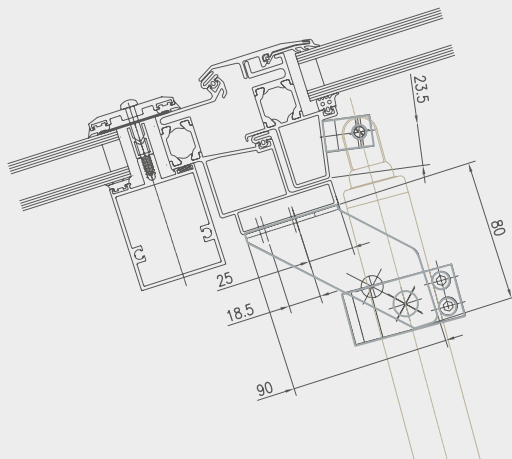

WSB 300 0011

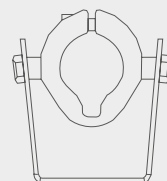

WSB 300 0003

WMS 309

# Spindle actuator 900N

## Installation suggestion 4

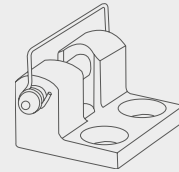
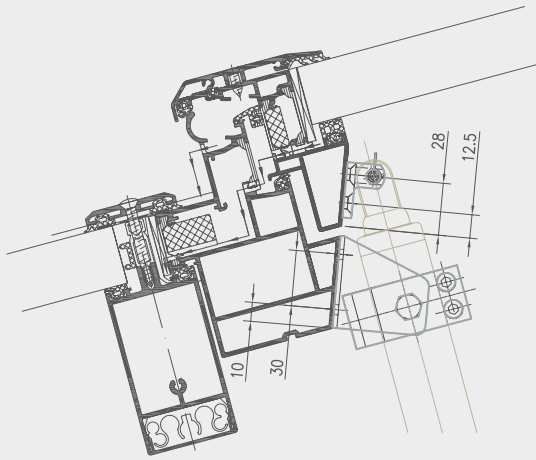

WSB 300 0012

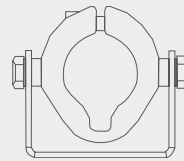

WSB 300 0001

