

WSC 310 & WSC 320 Standard versions

Installation instruction

CompactSmoke™

(Version 2307 – from firmware version 1.38 (main card))



Save this installation instruction to the end user

UK

+44 (0) 1536 614 070

Info.uk@windowmaster.com

Other markets

+45 4567 0300

Info.dk@windowmaster.com

www.windowmaster.com

1	Safety information	3
1.1	Safety	3
1.2	230V AC	3
1.3	Back-up batteries	3
1.4	Application	3
1.5	Cable routing and electrical connection	3
2	Structure of the smoke panel	4
3	Variants of panels	5
3.1	Max numbers of actuators per motor line and panel	5
4	Accessories and spare parts	7
5	Technical data	7
6	Mounting	9
7	Installation	9
7.1	Cable routing	9
7.2	Cables into housing	9
7.3	Connection of safety earth wire and 230V AC	9
7.4	Installation of the break glass unit, ventilation keypad and smoke detector	9
7.5	Assembly instructions	10
8	Cable dimensioning	10
8.1	Maintaining the cable functions	10
8.2	Max. cable Length	10
8.2.1	Formula for the calculation of the maximum actuator cable length	10
8.2.2	Max cable length – ±24V standard actuators	11
8.2.3	Max cable length – actuators with MotorLink®	11
9	Cable plan for connection to WSC 310 / 320 Standard version	13
10	Description of cards and mains connection	14
10.1	WSC 310 mains connection and power supply (WCA 3P1)	14
10.2	WSC 320 mains connection and power supply (WCA 3P2)	14
10.3	Main control card WCA 3SS – Standard Version	15
11	DIP switch configuration	21
12	Back-up batteries	22
13	Configuration of panel	23
13.1	Motor lines – motor groups – smoke zones	23
13.1.1	Assigned components per smoke zone	23
13.1.2	Examples with motor lines / motor groups / smoke zones	24
13.1.3	Motor line	24
13.1.4	Smoke zone	24
13.1.5	Local input	24
13.1.6	Local output	25
14	Fault detection via LED	25
14.1	Fault detection on the smoke panel	25
14.2	Fault indication on break glass unit	26
15	Hardware error	27
15.1	Error on the Power supply	27
15.1.1	Blown fuse – 20A fast	27
16	Commissioning and test run	27
16.1	The control ventilation panel is completely installed, without the operating voltage applied	28
16.2	With mains voltage, without accumulator	28
16.3	With mains voltage, with accumulator	28
16.4	Ventilation keypad	28
16.5	Break glass unit WSK 50x	28
16.6	Smoke detectors	28
16.7	Emergency power supply test	28
16.8	Wind/rain detector	28
17	Maintenance	29
17.1	Maintenance agreements	29
17.2	Replacement 3SS card	29
18	Declaration of Conformity and Declaration of Performance	29

1 Safety information

1.1 Safety

Only allow correspondingly trained, qualified and skilled personnel to carry out installation work.

Reliable operation and the avoidance of damage and hazards are only guaranteed if installation and settings are carried out carefully in accordance with these instructions.

There may be personal danger by electrically operated windows:

- the forces occurring in the automatic mode can be such that parts of the body could get crushed
- when opened, actuators (spindles) could protrude into the room

For this reason, measures have to be taken prior to starting up the actuators, which exclude the danger of injury.

For safety reasons we recommend to install opening restrictors on bottom-hung windows.

In the event that windows are subjected to rain and/or high wind loads, we recommend connecting a wind/rain sensor to the smoke ventilation panel for the automatically closing of the windows.

The smoke ventilation panel is to be located in a safe place, protected from the effects of fire and smoke.

The smoke ventilation panel is to be surface mounted.

The smoke ventilation panel has two energy suppliers: 230V AC and back-up batteries.

The manufacturer does not assume any liability for possible damage resulting from inappropriate use.

1.2 230V AC

230V AC can cause death, severe injury or considerable damage to assets.

The connection of the smoke ventilation panel is reserved for qualified personnel.

Disconnect all poles of the panel from the supply voltage prior to opening, installation or assembling.

Installation and use according to the national regulations.

1.3 Back-up batteries

Back-up batteries 2 batteries per panel can cause severe injury or considerable damage to assets.

The connection of the smoke ventilation panel is reserved for qualified personnel.

Disconnect all poles of the panel from the back-up batteries prior to installation or assembling.

Ensure that the mains cable can be switched via an external or customer-supplied two-pole switch element or a switch element controlling all poles – see section 7.1 “Cable routing”

Installation and use according to the National regulations.

Dispose of used batteries according to the National regulation.

CAUTION

RISK OF EXPLOSION IF BATTERIES ARE REPLACED BY AN INCORRECT TYPE.

1.4 Application

The smoke ventilation panel is exclusively designed for the automatic opening and closing of smoke extraction systems, windows, flaps or doors.

Always check that your system meets the valid national regulations.

Pay particular attention to the opening cross section, the opening time and opening speed.

The cable cross sections depend on the cable length and current consumption (amperage).

1.5 Cable routing and electrical connection

Fuse the 230V AC power supply cable separately on site.

Cable routing and connection - adhere to national regulations.

Establish the cable types, if necessary, with the local approval bodies or the fire protection authority.

Do not conceal flexible cables.

Junction box must be accessible for maintenance purposes.

Disconnect all poles of the mains voltage and the back-up batteries prior to starting maintenance work or making changes to the system.

Secure the system to prevent unintentional switching on again.

Route all low voltage cables (24V DC) separate from the power current cables.

Design cable types, lengths and cross sections in accordance with the technical information.

Cable specifications is a guide only, the overall responsibility resides with the electrical contractor on site.

Installation must be in accordance with the national electrical regulations.

2 Structure of the smoke panel

Sizes & Versions

The WSC 310 and WSC 320 smoke ventilation panels are available in two different versions namely a Standard and a Plus version. This installation instruction only deals with the Standard versions. Please see separate installation instruction for the Plus versions of WSC 310 and WSC 320.

Cards

Each panel contains a power supply unit (SMPS), either a WCA 3P1 or a WCA 3P2 for the 10A or 20A version respectively. Aside from the power supply unit the Standard version also includes a main control card type WCA 3SS.

If additional motor lines, inputs or fieldbus connection is required a Plus version of the panel is necessary.

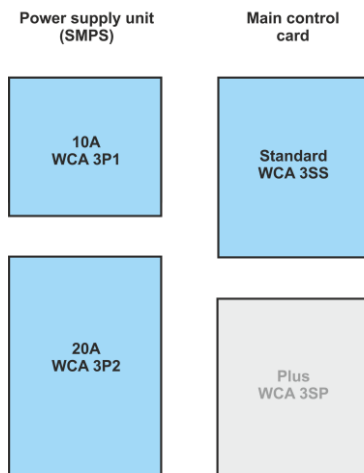

The Main control card type WCA 3SS allows connections of 2 motor lines and 2 keypads.

Motor groups and motor lines

A motor group consists of one or more motor lines and all the motor lines are operated simultaneously.

Both motor lines on the main control card (WCA 3SS) can be configured for either a $\pm 24V$ standard actuators or MotorLink[®] actuators. A motor group can contain motor lines with both $\pm 24V$ standard actuators and MotorLink[®] actuators, whereas a motor line only can have $\pm 24V$ standard or MotorLink[®] actuators connected.

Break glass unit

Break glass unit type WSK 50x are to be used together with WSC 310/320. The number of smoke zones is determined by the number of inputs to which break glass units are connected. On the Standard version max 2 smoke zones are possible.

Inputs

Cabling

The WSC 3xx CompactSmoke[™] uses bus technology and the overall cabling for break glass units, smoke detectors and keypads is significantly reduced compared to other types of smoke panels.

The main control card has 1 input for a smoke detector, 2 inputs for break glass units (where up to 10 break glass units can be connected) and 2 inputs for ventilation keypads (no max number of keypads).

Smoke detectors are either connected to the smoke detector input or to a break glass unit (type WSK 501 / 502).

The panel can have up to 2 smoke zones and 2 motor groups.

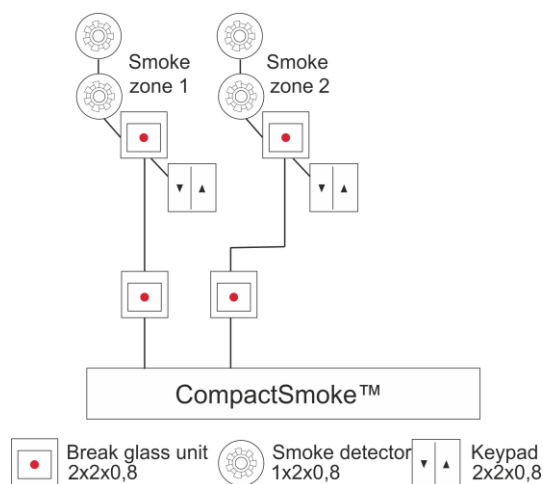

System example with WSC 320

Smoke ventilation panel (20A) with 2 smoke zones.

The keypads and smoke detectors are cabled directly to the break glass units in the smoke zones, which means that the need for cabling in the building is significantly reduced.

A wind/rain sensor is connected to close the windows during comfort ventilation in case of high wind and/or rain.

The smoke ventilation panel is connected to the Fire Alarm System via the WCA 3SS card.

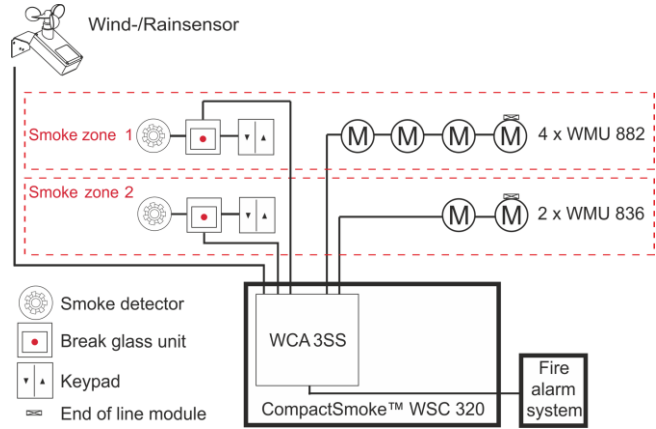

3 Variants of panels

Number of motor lines and other functions	Cards	Item number
WSC 310		
Standard version 2 motor lines 2 keypads / inputs	No cards	WSC 310 S 0202 Ex
WSC 320		
Standard version 2 motor lines 2 keypads / inputs	No cards	WSC 320 S 0202 Ex

The standard version of the panels have 16 DIP switches for easy configuration of the panel, see section 11 for further information.

3.1 Max numbers of actuators per motor line and panel

The table shows the maximum number of actuators, which can be connected per motor line and panel depending on the type of the actuators, panel and connected cards. The total power consumption of all the connected actuators must not exceed 10A or 20A depending on panel size.

WSC 320 with 20A includes up to two motor lines each with 10A. If there is a need of more than 10A on one motor line, DIP switch 2.6 is set to 20A. Hereafter one motor line can be loaded with 20A or two motor lines can be loaded up to a total of 20A e.g. 17A and 3A.

	Per Motor line		Per 10A Panel		Per 20A Panel	
	± 24V Actuator	MotorLink® Actuator	± 24V Actuator	MotorLink® Actuator	± 24V Actuator	MotorLink® Actuator
WMD 820-1	10	4	10	8	20	8
WMD 820-2	10	2	10	4	20	4
WMD 820-3	9	3	9	6	18	6
WMD 820-4	8	4	8	8	20	8
WMS 306-1	10	4	10	8	20	8
WMS 306-2	10	2	10	4	20	4
WMS 306-3	9	3	9	6	18	6
WMS 306-4	8	4	8	8	20	8
WMS 309-1	10	4	10	8	20	8
WMS 309-2	10	2	10	4	20	4
WMS 309-3	9	3	9	6	18	6
WMS 309-4	8	4	8	8	20	8
WMS 409 xxxx 01	5	0	5	0	10	0
WMS 409-1	5	4	5	4	10	8
WMS 409-2	4	2	4	4	8	4
WMS 409-3	3	3	3	3	9	6
WMS 409-4	4	4	4	4	8	8

	Per Motor line		Per 10A Panel		Per 20A Panel	
	± 24V Actuator	MotorLink® Actuator	± 24V Actuator	MotorLink® Actuator	± 24V Actuator	MotorLink® Actuator
WMU 831 / 836 / 851-1	10	4	10	8	20	8
WMU 831 / 836 / 851-2	10	2	10	4	20	4
WMU 831 / 836 / 851-3	9	3	9	6	18	6
WMU 831 / 836 / 851-4	8	4	8	8	20	8
WMU 861-1	6	4	6	6	12	8
WMU 861-2	6	2	6	4	12	4
WMU 861-3	6	3	6	6	12	6
WMU 861-4	4	4	4	4	12	8
WMU 842 / 852 / 862 / 882-1	4	4	4	4	8	8
WMU 842 / 852 / 862 / 882-2	4	2	4	4	8	4
WMU 842 / 852 / 862 / 882-3	3	3	3	3	6	6
WMU 842 / 852 / 862 / 882-4	4	4	4	4	8	8
WMU 863 / 883-1	2	2	2	2	6	6
WMU 863 / 883-2	2	2	2	2	6	4
WMU 863 / 883-3	0	0	0	0	6	6
WMU 863 / 883-4	0	0	0	0	4	4
WMU 864 / 884-1	2	2	2	2	4	4
WMU 864 / 884-2	2	2	2	2	4	4
WMU 864 / 884-3	0	0	0	0	3	3
WMU 864 / 884-4	0	0	0	0	4	4
WMU 885 / 895-1	2	2	2	2	4	4
WMU 885 / 895-2	2	2	2	2	4	4
WMU 885 / 895-3	0	0	0	0	3	3
WMU 885 / 895-4	0	0	0	0	4	4
WMX 503 / 504 / 523 / 526-1	20	4	20	8	40	8
WMX 503 / 504 / 523 / 526-2	20	2	20	4	40	4
WMX 503 / 504 / 523 / 526-3	18	3	18	6	39	6
WMX 503 / 504 / 523 / 526-4	20	4	20	8	40	8
WMX 803 / 804 / 813 / 814 / 823 / 826-1	10	4	10	8	20	8
WMX 803 / 804 / 813 / 814 / 823 / 826-2	10	2	10	4	20	4
WMX 803 / 804 / 813 / 814 / 823 / 826-3	9	3	9	6	18	6
WMX 803 / 804 / 813 / 814 / 823 / 826-4	8	4	8	8	20	8
WML 820/825	10	0	10	0	20	0
WML 860-1	10	4	10	8	20	8
WML 860-2	10	2	10	4	20	4
WML 860-3	9	3	9	6	18	6
WML 860-4	8	4	8	8	20	8
WMB 801/802*	max. 4A connected to the WMB					
WMB 811/812 */**	10	2	10	4	20	4

* Do not exceed the total power consumption of the motor line

** When having two locking actuators per motor line, it must be one of each type: 1 x WMB 811 and 1 x WMB 812

4 Accessories and spare parts

Accessories	
Back-up battery for WSC 310 - 7Ah (2 x WSA 007 per panel)	WSA 007
Back-up battery for WSC 320 - 12Ah (2 x WSA 012 per panel)	WSA 012
Break glass unit, primary, with data communication, PVC housing. With input for smoke detector and comfort keypads. Only one unit per line. x = colour of the housing: 1=red, 2=yellow, 3=grey, 5=orange	WSK 501 000x
Break glass unit, primary, with data communication, metal housing. With input for smoke detector and comfort keypads. Only one unit per line. x = colour of the housing: 2=yellow, 3=grey, 5=orange	WSK 502 000x
Break glass unit, primary, with data communication, PVC housing. No input for smoke detector or keypad. Max five units per line. x = colour of the housing: 1=red, 2=yellow, 3=grey, 5=orange	WSK 503 000x
Break glass unit, primary, with data communication, metal housing. No input for smoke detector or keypad. Max five units per line. x = colour of the housing: 2=yellow, 3=grey, 5=orange	WSK 504 000x
Smoke detector	WSA 311
Rain sensor	WLA 331
Rain/wind speed sensor	WLA 330
End of line motor module	WSA 510
End of line smoke detector module (10kΩ resistor), 10 pcs.	WSA 501
Cables for smoke ventilation – see separate data sheet for further information	WLL 8xx
USB stick for log-data, back-up and firmware updates	WCA 304
Comfort keypad for 1 window or 1 window group	WSK 110 0A0B
Comfort keypad for 2 windows or 2 window groups	WSK 120 0A0B 0A0B
Spare parts	
10A power supply unit for WSC 310	WCA 3P1
20A power supply unit for WSC 320	WCA 3P2
Main control card for Standard version WSC 310 / WSC 320 incl. cover + 2 end of line modules (WSA 510)	WCA 3SS
Plastic cover for the main control card in the WSC 310 / WSC 320 Standard version	WCA 302
Lock cylinder incl. 2 keys for WSC 310/320 panel	WCA 307
Replacement glass for break glass units type WSK 501 / 502 / 503 / 504, 5 pcs.	WSK 397
Keys for break glass units type WSK 501 / 503, 5 pcs.	WSK 398
Keys for break glass units type WSK 502 / 504, 1 pcs.	WSK 453
Lockable replacement PVC housing for break glass unit x=colour of the housing: 1 = red, 2 = yellow, 3 = grey, 5 = orange	WSK 399 000x
Back-up battery cable kit for WSC 310 / 320 (cable between WCA 3SP / 3SS and the batteries and between the batteries)	WSA 330 0101
20A battery fuse. The battery fuse on the WCA 3SP/3SS, 10 pcs	WSA 331 0101

5 Technical data

Technical data	
Output current (nominal)	WSC 310: 10A / WSC 320: 20A
Secondary voltage	Voltage 24V DC (±15%) Open circuit voltage (no load) 27.6V DC @ 20°C Ripple at max load max. 6% (3.5Vpp)
Motor lines Motor groups Smoke zones	2 motor lines – a line can be either ±24V standard motor line or MotorLink® motor lines - in max 2 motor groups and max 2 smoke zones

Primary voltage	WSC 310: 230V AC, 50Hz (85-264V AC, 47-63Hz) WSC 320: 230V AC, 50Hz (85-264V AC, 47-63Hz)	
Power consumption	WSC 310: min 3.2W ¹⁺² , typ. 4.8W ¹⁺³ . At max load 300W WSC 320: min 5.0W ¹⁺² , typ. 5.6W ¹⁺³ . At max load 600W 1) no load: system operational but no actuators are running 2) min: 1 x break glass unit WSK 501 and 1 x smoke detector WSA 311 3) max load: 1 x break glass unit WSK 501, 4 x break glass unit WSK 503 and 10 x smoke detector WSA 311	
Inrush current on primary site	70A<5ms Max. 3 x WSC 310/320 per 10A supply group. Circuit breaker "C" characteristic.	
±24V change over time	min 500ms	
Back-up batteries	WSC 310: 2 x WSA 007 (12V / 7Ah) WSC 320: 2 x WSA 012 (12V / 12Ah) Expected lifetime max 4 years, only use genuine WindowMaster batteries	
Emergency power	>72 hours in accordance with EN 12101-10	
Automatic smoke triggering	Smoke triggering when the temperature inside the compact unit exceeds 72°C	
Charging unit (integrated in WCA 3SS card)	Charging voltage: 27.7 – 27.8V at 20°C Charging current: 1.7A, current limited	
Priority	Smoke signal has always highest priority	
Cable monitoring	±24V standard actuators with end of line module and smoke detectors are monitored by closed-circuit Actuators with MotorLink® and break glass units are monitored by data communication Back-up batteries are monitored by cyclic measuring	
LED message OK, fault and alarm	Green Yellow Red	all OK fault fire
Reopening the actuators	Every 2.min. in 30min. after a SHE open (selectable) Pre-set: <u>no</u> reopening	
Connection cable	Actuators Other components	flexible max 6 mm ² / solide max 10 mm ² min 0,2mm ² / max 1,5mm ²
Operating conditions	-5°C - +40°C, max. 95% relative humidity (not condensing) EN 12101-10: Operation class A, Environmental class 1, with IP value increased to IP 54 (according to EN 12101-10 is min. IP 30 required)	
Max actuator activation duration (duty cycle)	ED 40% (4min. per 10min.)	
Max allowed current drawn from the battery when the primary power source is disconnected	WSC 310: 10A WSC 321: 20A	
Max interruption time during switching between power sources	<2.0sec	
Break glass unit	Up to 10 break glass units type WSK 50x can be connected to the WCA 3SS, but only 1 WSK 501 / 502 per line, meaning max 2 WSK 501 / 502 per panel. Smoke detectors and ventilation keypads can only be connected to the break glass units type WSK 501 / 502. Up to 10 smoke detectors can be connected to each WSK 501 / 502, and 10 smoke detectors can be connected to the smoke detector input on the main control card, which give a total maximum of 30 smoke detectors. There is no limit on the number of ventilation keypads connected to the WSK 501 / 502. Smoke detectors and ventilation keypads <u>cannot</u> be connected to WSK 503 / 504.	
Number of motor lines	2 x 10A motor line for ±24V standard or MotorLink® actuators	
Material	Metal housing for surface mounting	

Colour	Grey (RAL 7035)
Size	WSC 310: 300 x 400 x 120mm (HxWxD) WSC 320: 300 x 400 x 210mm (HxWxD)
Weight	WSC 310: 6kg no batteries, 10.8kg with batteries (2 x WSA 007) WSC 320: 8.6kg no batteries, 16.6kg with batteries (2 x WSA 012)
Protection class	IP 54
Approval / certification	Approved and certified according to EN 12101-10
Delivery	CompactSmoke™ smoke ventilation panel with WSA 501 (10kΩ resistors, 10 pcs.) and 2 pcs. end of line module WSA 510. Back-up batteries included.
Note	We reserve the right to make technical changes

6 Mounting

The smoke ventilation panel is fixed to the wall through the Ø8.5mm holes in the back plane of the housing.

If the panel is fixed in different way, the holes are to be blinded with the 4 blind grommets, this way the IP class is maintained.

The door is turnable.

When turning the door also move the blind grommets to the new holes.

The smoke ventilation panel is to be located in a safe place, protected from the effects of fire and smoke.

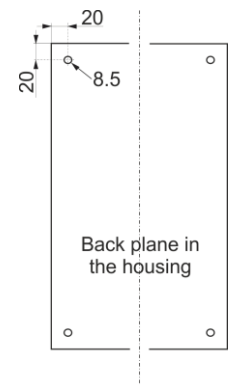

7 Installation

7.1 Cable routing

For cable routing we recommend the use of fire protected cables retaining their function E90 or E30.

See also chapter 8 "Cable dimensioning" in this instruction.

However, this has to be agreed with the Engineer or, if necessary, with the local fire protection department.

Do not reduce the cable cross sections specified in the cable lengths table.

All cables of the control (except the mains supply cable) carry 24V DC and have to be routed separate from the mains supply cable.

Adhere to the pertinent national and local regulations when routing the cables.

Lead the connection cables into the housing of the control panel from above and the cable glands shall comply with fire class V-1 (IEC/EN 60695-11-20 / UL 94) or higher and be in accordance with national and local regulations.

Ensure that the mains cable can be switched via an external or customer-supplied two-pole switch element or a switch element controlling all poles – see drawing.

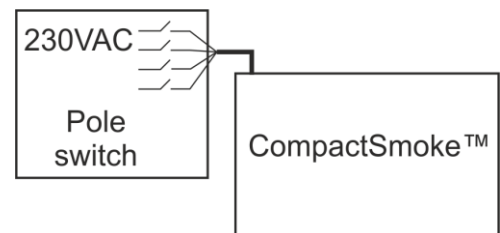

7.2 Cables into housing

All connection terminals (except the mains terminals) are of the plug-in type.

Connect the connection cables in accordance with the terminal plan. Ensure that the connections are made correctly.

Incorrect cable clamping, mixing up numbers or colours could lead to malfunctions of the control panel or of the external components.

Ensure that the electrical cables are always routed according to the valid national and local regulations.

7.3 Connection of safety earth wire and 230V AC

See chapter 10 'Description of cards', section 10.1 for further description.

7.4 Installation of the break glass unit, ventilation keypad and smoke detector

Ensure that the break glass unit and the ventilation buttons are visible and well accessible. Do not install behind protruding walls, door panels or hidden by the building structure.

Note: Installation height of the break glass unit 1.5 – 1.7m above floor.

Install the smoke detectors in accordance with their enclosed instructions

7.5 Assembly instructions

Always have assembly, installation, repair and maintenance of smoke and heat extraction systems carried out by qualified personnel trained for this purpose.

Rules to be adhered to for setting up and installation

The following safety relevant rules have to be adhered to when planning the use of a smoke and heat extraction system and its set-up and installation:

- The Provincial Building Ordinance of the provinces,
- The regulations of the competent fire protection authority,

Accident prevention regulations

Adhere to the general accident prevention regulations (APR), the APR for power operated windows and doors, and the installation rules in your country.

CAUTION:

Live components are directly accessible after opening the system housing.

Prior to inserting / removing cards disconnect to the panel from the mains supply and the back-up batteries.

- adhere to the installation instructions and your local energy providers
- select the place of installation such that free access is guaranteed for maintenance purposes
- select cables according to regulations in this instruction - take the calculation of the actuator supply cable lengths into account when laying the cables
- power cables entered via the cable glands
- connect the cables in accordance with the drawings provided by the manufacturer
- route the cables in the building according to the regulations in this instruction
- after the smoke panel is installed the back-up batteries will be fully charged after ca. 8 hours
- check all system functions

Electric cable routing for smoke and heat extraction systems

Electrical cables always have to be laid in accordance with the national and local rules in your country.

Do not use the PE wire / green/yellow wire!

Cables of type NYM, concealed, can be used.

For surface laying, halogen free safety cables are recommended (see cable plan).

If possible, the use of cable types should be agreed with the Technical Services and the competent fire protection authority.

For the maximum permissible cable lengths of the actuator supply cables for the WSC 3xx system, taking the specified cable cross sections into account (cable information for surface laying), please refer to chapter 8 "Cable dimensioning".

8 Cable dimensioning

8.1 Maintaining the cable functions

According to valid national regulations.

The cable network for smoke ventilation systems ("Cable system") ends normally at the interface (junction box) for the actuator! The flexible, heat resistant connection cable of actuator is part of the system component, electric actuator actuation, and is not a part of the electrical installation!

We recommend in all cases to discuss the type of cable routing with the competent fire fighting authorities.

8.2 Max. cable Length

Maximum permissible cable length from the smoke ventilation panel to the actuators and pyrotechnic gas generator taking into account the cable cross-section is shown in the following tables for "± 24V standard actuators", "MotorLink® actuators" and pyrotechnic gas generator.

8.2.1 Formula for the calculation of the maximum actuator cable length

$$\text{Max. cable length} = \frac{\text{permissible voltage drop } 2V \text{ (UL)} \times \text{conductivity of copper(56)} \times \text{cable cross section in mm}^2 \text{ (a)}}{\text{max. actuator current total in amps (I)} \times 2}$$

For both ±24V standard actuators and actuators with MotorLink® the cross section of the cable must not be less than 0.75mm² regardless of the result of above formula.

Maximum actuator cable length: Always measured from the smoke to the last junction box

Permissible max. voltage drop in the line: 2 Volt

Actuating current: Sum of all actuator power consumption per motor line

Note: do not use the PE wire / green/yellow wire!

Example

Max actuator cable length with cable cross section 0.75mm² and actuator current 2A: $(2 \times 56 \times 0.75) : (2 \times 2) = \underline{21m}$

8.2.2 Max cable length – ±24V standard actuators

The actuator supply cable must have 3 wires: 2 wires current carrying / 1 wire for monitoring.

±24V standard Actuators						
Do not use the PE wire / green/yellow wire!						
cable cross section [a]	3 wire 0.75mm²	3 wire 1.50 mm²	5 wire 1.50 mm² 2 wire parallel	3 wire 2.50 mm²	5 wire 2.50 mm² 2 wire parallel	3 wire 4.00 mm²
Total actuator current [I]						
1A	42m	84m	168m	140m	280m	224m
2A	21m	42m	84m	70m	140m	112m
3A	14m	28m	56m	47m	93m	75m
4A	11m	21m	42m	35m	70m	56m
5A	8m	17m	34m	28m	56m	45m
6A	7m	14m	28m	23m	47m	37m
7A	6m	12m	24m	20m	40m	32m
8A	5m	11m	21m	18m	35m	28m
9A		9m	18m	15m	31m	25m
10A		8m	16m	14m	28m	22m
20A		4m	8m	7m	14m	11m

8.2.3 Max cable length – actuators with MotorLink®

The actuator supply cable must have 3 wires: 2 wires current carrying / 1 wire for communication.

When a 5 wire cable is used for MotorLink®

It is not recommended to use parallel-wire.

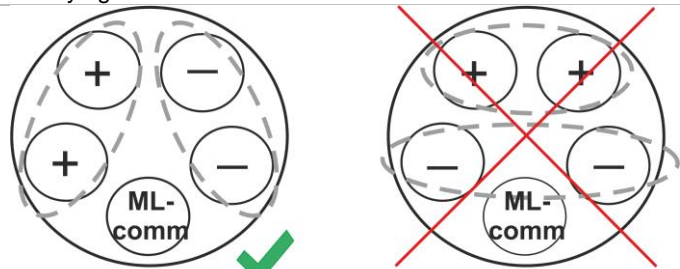

ML-comm = MotorLink® communication

Furthermore, when using a 5-core cable, the distance between "-" and "Com" must be the same as the distance between "+" and "Com".

Meaning if L2 e.g. is being used as "Com" L1 and L3 must be used for "+" and "-".

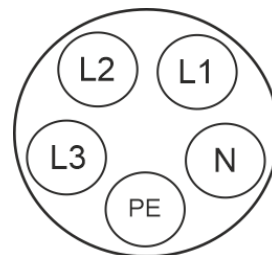

When using actuators with MotorLink® the max/total cable length is 50m regardless of the result of the above mentions formula.

Actuators with MotorLink®						
Do not use the PE wire / green/yellow wire!						
cable cross section [a]	3 wire 0.75mm ²	3 wire 1.50 mm ²	5 wire 1.50 mm ² 2 wire parallel	3 wire 2.50 mm ²	5 wire 2.50 mm ² 2 wire parallel	3 wire 4.00 mm ²
Total actuator current [I]						
1A	42m	50m				
2A	21m	40m	50m			
3A	14m	28m	50m	47m	50m	
4A	11m	21m	42m	35m	50m	
5A	8m	17m	34m	28m	50m	45m
6A	7m	14m	28m	23m	47m	37m
7A	6m	12m	24m	20m	40m	32m
8A	5m	11m	21m	18m	35m	28m
9A		9m	18m	15m	31m	25m
10A		8m	16m	14m	28m	22m
20A		4m	8m	7m	14m	11m

Definition of total cable length

The total cable length is defined as the sum of all cables from the MotorController output to the last actuator. Including the cable mounted on the actuator.

For example, in case of 4 actuators with 5m cable each, the remaining cable length is 30m.

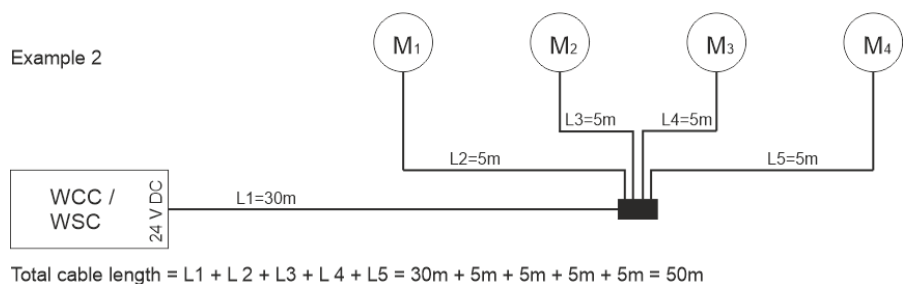
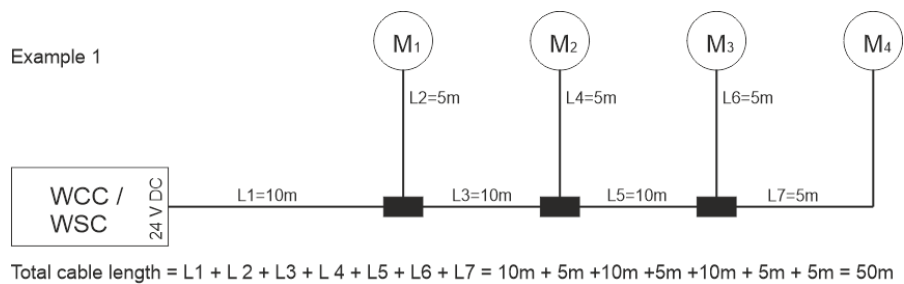

9 Cable plan for connection to WSC 310 / 320 Standard version

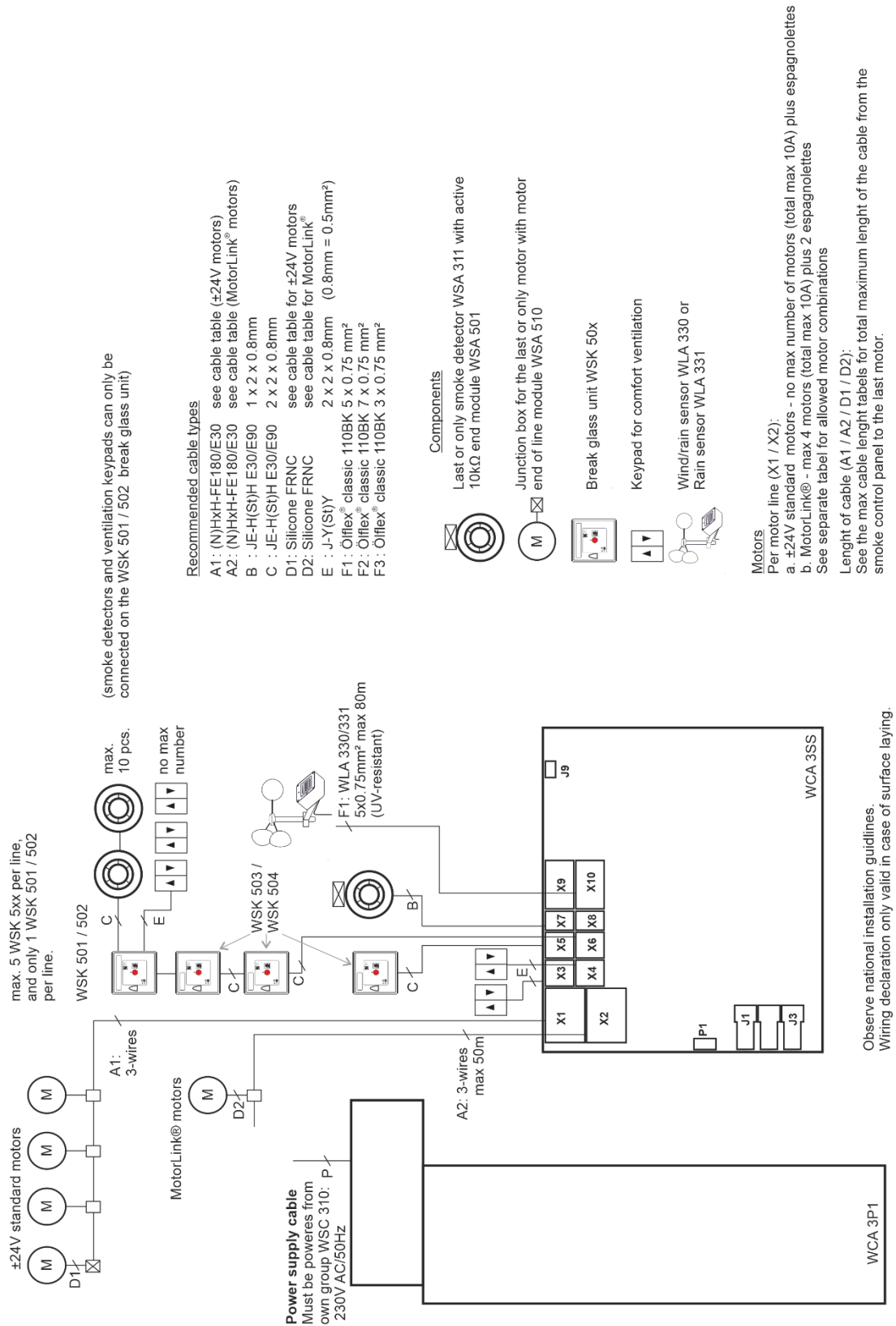

The above plan shows a WSC 310 panel, where the power supply unit is located in the left side of the panel wherefrom also mains is pulled. The power supply unit for the WSC 320 panel is located underneath the main control card and mains is pulled from the top right side. See section 10.1.

10 Description of cards and mains connection

Each panel includes a power supply unit (SMPS) and a main control card.

The size of the power supply unit determines the size of the panel and the number and/or types of actuators, which can be connected to the panel. See table with overview of max number of allowed actuators per motor line/panel (chapter 0).

The size of the power supply also determines the physical design of the panel inside the cabinet and thereby eg. where mains is connected to the main control card (WCA 3SS).

10.1 WSC 310 mains connection and power supply (WCA 3P1)

<p>WSC 310 – WCA 3P1 With 300W SMPS unit</p> <p>The power supply is located to the left of the main control card.</p> <p>The cable inlet is in the top left corner of the panel.</p> <p>The panel must be grounded by means of protective earth on the top panel plate.</p>	
<p>Connection to mains.</p>	

10.2 WSC 320 mains connection and power supply (WCA 3P2)

<p>WSC 320 - WCA 3P2 With 600W SMPS unit</p> <p>The power supply is located underneath the main control card.</p> <p>The cable inlet is in top right corner of the panel.</p> <p>The panel must be grounded by means of protective earth on the top right side of the panel.</p>	
<p>Connection to mains.</p>	

10.3 Main control card WCA 3SS – Standard Version

Each WCA 3SS contains the following:

- 2 motor line for ±24V standard or MotorLink® actuators
- 2 input for keypads for comfort ventilation
- 2 input for break glass units
- 1 input for smoke detector
- 1 input for 24V/48V
- output for fault signal to Fire Alarm System
- Input for weather station (WLA 330 / 331)
- Connection of power supply
- Connection for battery back-up
- Connection for USB device

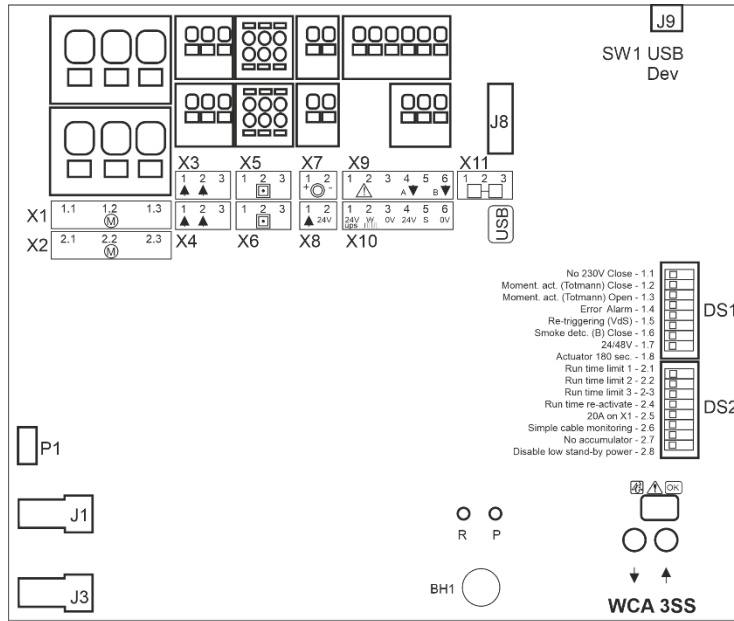

<p>X1 1.1 24V / 0V 1.2 Cable monitoring / MotorLink® 1.3 0V / 24V</p> <p>X2 2.1 24V / 0V 2.2 Cable monitoring / MotorLink® 2.3 0V / 24V</p> <p>X3 3.1 Open 1.1 3.2 Close 1.2 3.3 GND / 0V</p> <p>X4 4.1 Open 2.1 4.2 Close 2.2 4.3 GND / 0V</p> <p>X5 5.1 24V 5.2 Comm. 5.3 0V</p> <p>X6 6.1 24V 6.2 Comm. 6.3 0V</p> <p>X7 7.1 + 7.2 -</p> <p>X8 8.1 + 8.2 -</p> <p>X9 9.1 Fault 9.2 Fault 9.3 Output A 9.4 Output A 9.5 Output B 9.6 Output B</p>	<p>Motorline</p> <p>Motorline</p> <p>Comfort key pad #1</p> <p>Comfort key pad #2</p> <p>Break glass unit WSK 501 #1</p> <p>Break glass unit WSK 501 #2</p> <p>Smoke detector WSA 311</p> <p>24V / 48V input</p> <p>Output</p>	<p>X10 10.1 24V UPS 10.2 Wind speed 10.3 GND / 0V 10.4 24V 10.5 Rain 10.6 GND / 0V</p> <p>X11 11.1 24V IN 11.2 Comm. IN 11.3 0V IN</p> <p>DS1 DIP switches 1.1 - 1.8</p> <p>DS2 DIP switches 2.1 - 2.8</p> <p>J1 Power from power supply</p> <p>J3 Battery pack connection</p> <p>J8 USB host</p> <p>J9 USB device</p> <p>P1 Control for power supply</p> <p>R / P Reset / Programming</p> <p>↓ ↑ Close and open all windows Auto configuration</p> <p>BH1 VBAT, back-up battery for CPU and system clock</p>	<p>Weather station</p> <p>WSK-Link™ for Master/Slave connection (Isolated) (only available on Plus version)</p>
--	--	--	---

X1 / X2 The WCA 3SS card has 2 motor lines (X1 and X2) for connection of ±24V standard or MotorLink® actuators.

±24V standard actuators

1.1 24V / 0V	2.1 24V / 0V
1.2 Cable monitoring	2.2 Cable monitoring
1.3 0V / 24V	2.3 0V / 24V

MotorLink® actuator

1.1 0V	2.1 0V
1.2 Communication	2.2 Communication
1.3 24V	2.3 24V

The number of actuators per motor line depends on the actuator type, the total power consumption of actuators connected to a motor line can max be 10A and the total max power consumption for both motor lines must not exceed 10A or 20A depending on panel type.

Besides actuators also locking actuators (espagnolettes actuators) type WMB 801/802 and WMB 811/812 can be connected. The power consumption of the locking actuators are not to be included in the 10A / 20A as actuators and locking actuators do not run at the same time.

All actuators on the same motor line will run/be operated simultaneously.
 All actuators on the same motor line must be of the same type.

Connection / cable diameter: flexible max 6 mm² / solid max 10 mm².
 Cable length: see the chapter "Cable dimensioning".

Standard ±24V actuators

- Examples with 20A power consumption
- a) 20 pcs. WMX 826-1
 - b) 10 sets of 2 pcs. WMX 826-2
 - c) 4 pcs. WMU 885-1
 - d) 2 sets of 2 pcs. WMU 885-2

Connection of standard actuators on motor line X1 (with cable monitoring)

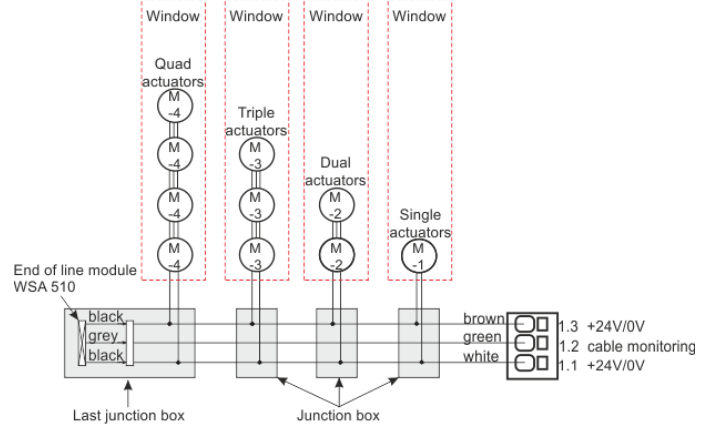

Cable monitoring

When using ±24V standard actuators or non-WindowMaster actuators and cable monitoring is wanted a 10kΩ resistor is used. An "end of line motor module" type WSA 510 must be added in the last junction box. Actuator are per default monitored.

MotorLink® actuators

- Examples with actuators per motor line
- Ex. 1: 4 pcs. WMX 823-1
 - Ex. 2: 2 pcs. WMX 885-2
 - Ex. 3: 3 pcs. WMU 826-3

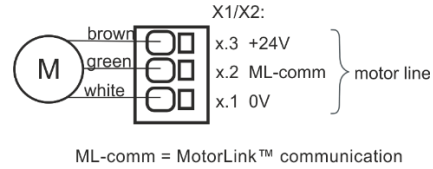

Allowed actuator combinations on a MotorLink® motor line

The two motor lines on the SS card can each be connected to one of the below shown combinations.

- 1 (single): one window with one single window actuator. Up to four windows each with one single window actuator can be connected
- 2 (double): one window with two double window actuators.
- 3 (triple): one window with three triple window actuators.
- 4 (quad): one window with four quad window actuators.

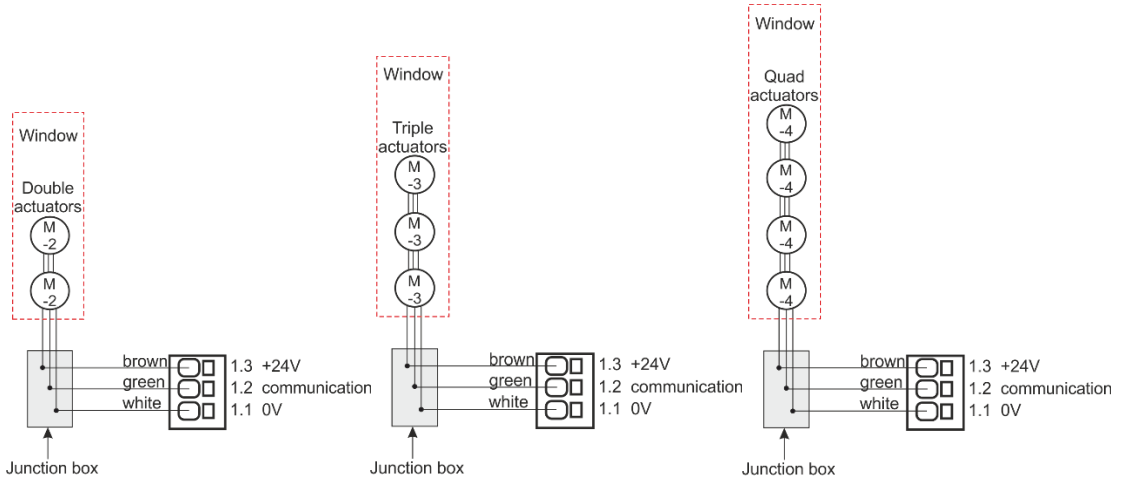
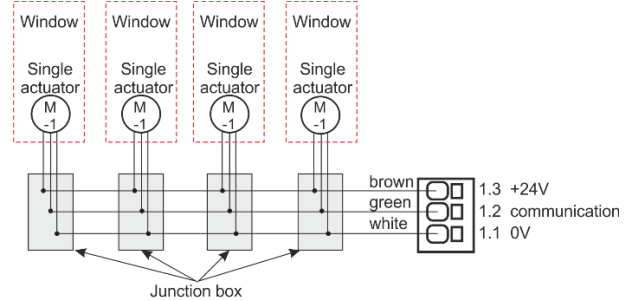

Cable monitoring

When using actuators with MotorLink® the actuators with MotorLink® are monitored by data communication. When the team-size does not match, an error is indicated on the diodes.

X3 / X4

For connection of comfort keypads. S1.X3 and S1.X4 are potential free / dry contacts.

Data

- | | |
|--------------|--------------|
| 3.1 Open | 4.1 Open |
| 3.2 Close | 4.2 Close |
| 3.3 GND / 0V | 4.3 GND / 0V |

With the default values are input:

"Active" if the contact resistance is smaller than 2kΩ

"Inactive" if the contact resistance is bigger than 3kΩ.

Input has pull up current of approx. 0.8mA. (min 0.7mA, max 1mA)

Example: comfort keypad connected to input X3

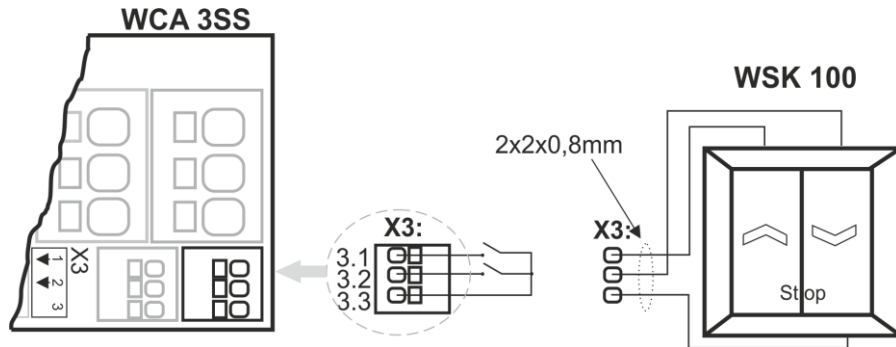
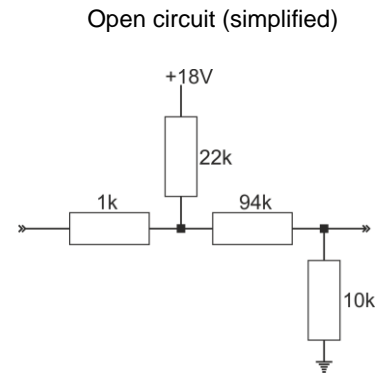

X5 / X6

For connection of break glass unit type WSK 50x.

Data

- | Break glass unit bus 1 | Break glass unit bus 2 |
|------------------------|------------------------|
| 5.1 24V | 6.1 24V |
| 5.2 Communication | 6.2 Communication |
| 5.3 0V | 6.3 0V |

If there is only 1 smoke zone, the break glass unit must be connected to X5 and not X6.

Up to 5 break glass units type WSK 503 or WSK 504 can be connected to each line. If keypad and smoke detector are to be connected to the break glass unit, WSK 501 or WSK 502 are to be used. Max one of these break glass unit on each motor line, the remaining units (up to four) must be of type WSK 503 or WSK 504.

As the break glass units are monitored, the connection of the break glass units depends therefore of the number of smoke zones.

Break glass unit must not be connected in a ring bus.

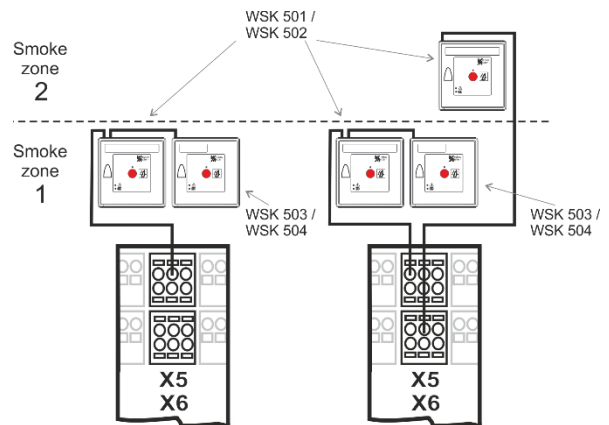

Keypads and smoke detectors can also be connected on the break glass unit type WSK 501 / 502.

Per panel up to 10 break glass units can be connected.

But only 2 of these 10 (one per line) can be a type WSK 501 / 502 to which keypads or smoke detectors can be connected. The remaining break glass units must be type WSK 503 / 504.

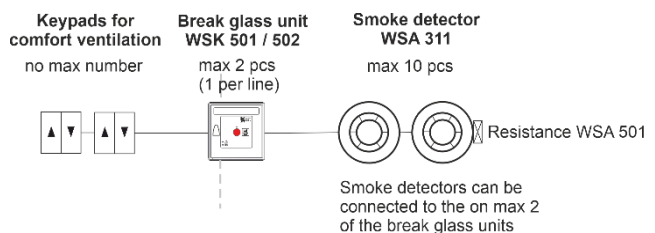

Example:

2 smoke zones and connected components; 2 break glass units type WSK 501 / 502 and 1 break glass unit type WSK 503 / 504, 3 smoke detectors WSA 311, 2 resistances WSA 501 and 3 comfort keypads.

Example

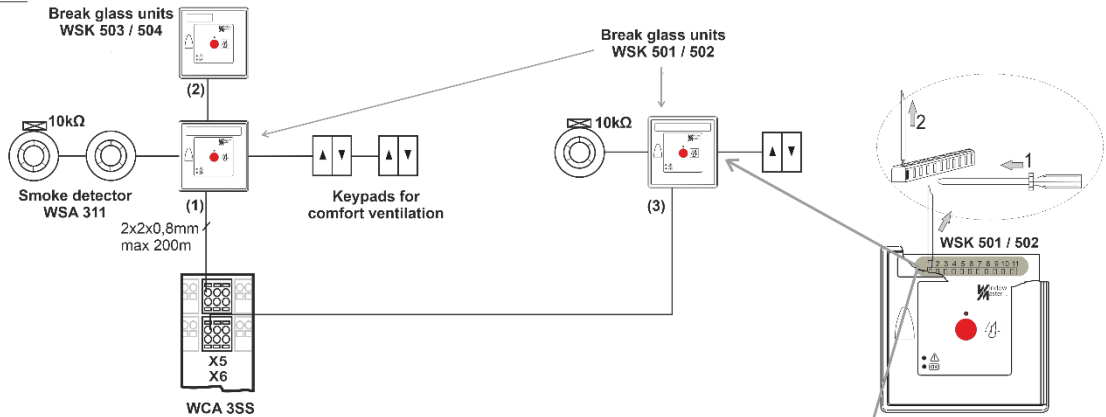

Wiring diagram for example

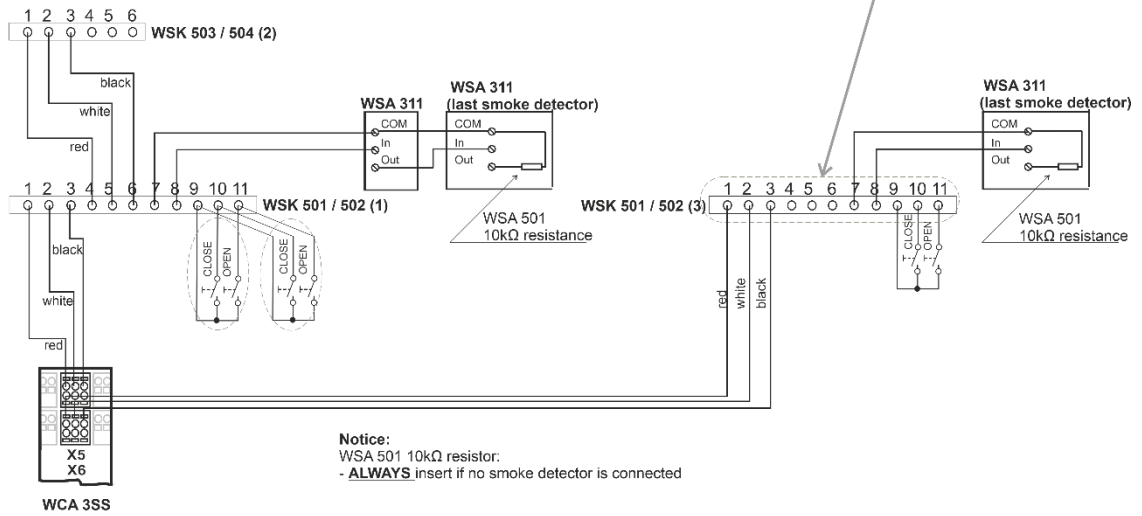

Notice:
WSA 501 10kΩ resistor:
- **ALWAYS** insert if no smoke detector is connected

When there is no smoke detector connected to the WSK 501 / 502 a 10kΩ resistor must be connected to the break glass unit in to pin 7 and 8.

When a smoke detector is connected to the break glass unit, the 10kΩ resistor must be connected to the last smoke detector.

See chapter 9 "Cable plan for connection to WSC 3xx" for cable types and lengths.

Connection of different types of smoke detectors to CompactSmoke™

		Smoke detector type			
		WSA 300	WSA 311	Hekatron MSD 523 (max 5 pcs)	Hekatron SSD 521/a (WSA 200 6101)
Connect to WCA 3SS	X1,1	L1 In	In +	2	2
	X1,2	L2	Com -	1	1
Connect to WSK	p 7	L2	Com -	1	1
	p 8	L1 In	In +	2	2
ALWAYS connect 10 KOhm in between		L2 and L1 Out	Com - and Out +	1 and 3	1 and 3

X7

For connection of smoke detector type WSA 311.

Data

7.1 +

7.2 -

$I_{max} = 3,4mA$

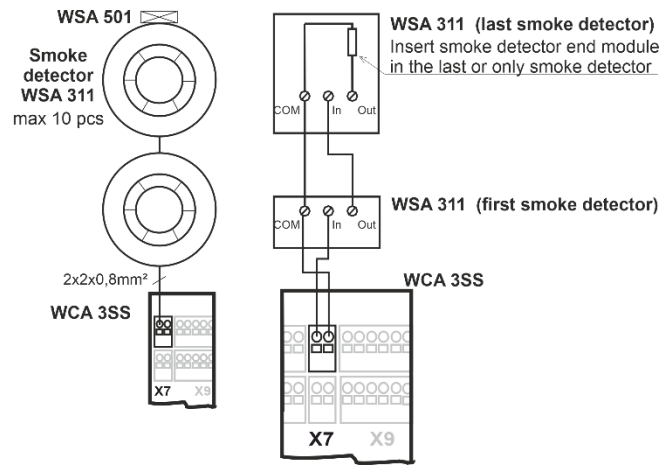

For connection of a different type smoke detector, see above.

When no smoke detector is connected to X7, a 10kΩ resistor is connected to the input.

X8

24/48V input from e.g. Fire Alarm System (used primarily in France).

Data

8.1 +

8.2 -

Active at voltages between 18 and 50V

Passive below 1V

Max.50V

This input is only active when DIP switch 1.7 is ON, see section 11.

When this input is in use, break glass units cannot be connected to the panel.

Connection example

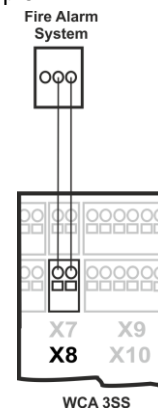

X9

Solid state outputs, one solid state output for transmission of fault signal to Fire Alarm System and 2 outputs indicating alarm in the smoke zones.

Data

9.1 Fault – Open contact = Fault, closed contact = OK

9.2 Fault – Open contact = Fault, closed contact = OK

9.3 Output A, smoke zone 1 alarm – Open contact = normal, closed contact = Alarm

9.4 Output A, smoke zone 1 alarm – Open contact = normal, closed contact = Alarm

9.5 Output B, smoke zone 2 alarm – Open contact = normal, closed contact = Alarm

9.6 Output B, smoke zone 2 alarm – Open contact = normal, closed contact = Alarm

Solid state output for transmission of fault signal to Fire Alarm System.

A fault must last a minium of 20 seconds before the relay indicate a fault.

Data

Max voltage: 30 Vp (peak)

Max output: 150 mA

Typical On-resistance: 4,7 Ω

Max On-resistance: 8 Ω

Max switching speed: 2 ms

X10

For connection of weather station.

Connection of wind / rain sensors type WLA 330 or rain sensor WLA 331.

Data

- 10.1 24V UPS (only available with Plus version)
- 10.2 Wind speed (only available with Plus version)
- 10.3 GND / 0V (only available with Plus version)
- 10.4 24V
- 10.5 Rain (potential free / dry contact) (10kΩ resistor is to be inserted when a rain sensor is not connected)
- 10.6 GND / 0V

With the default values are input:

"Active" if the contact resistance is smaller than 4kΩ

"Inactive" if the contact resistance is bigger than 8kΩ.

For values between 4 and 8kΩ the result will depend on the supply voltage.

Input has pull up approx. 1mA. (min 0.7mA, max 1.4mA)

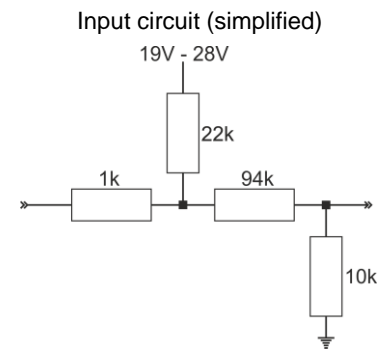
**Example: Wind/rain and rain sensors**

WLA 330 and WLA 331 – the settings of the sensors are set on the sensor.

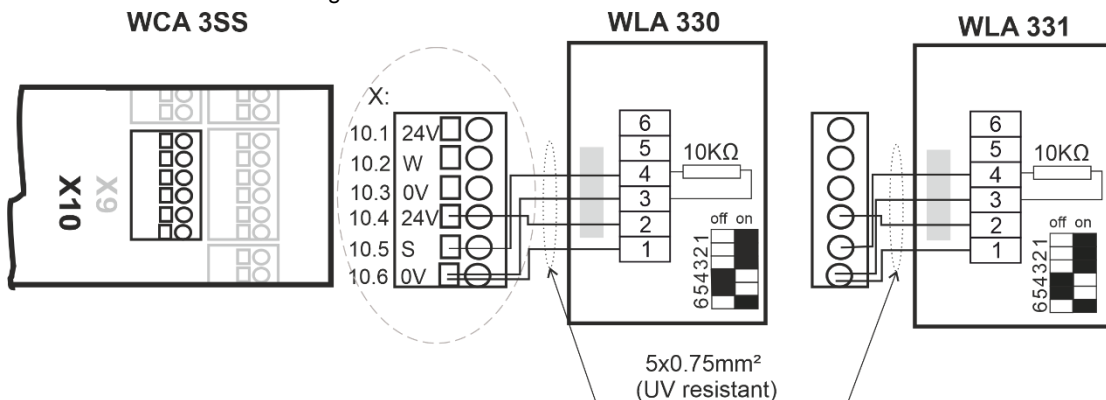
**J1**

Connection for power supply

J3

Connection for battery (power back-up)

J8

USB host. Used for event log creation for e.g. error detection

J9

USB device. Used for remote control and update of firmware

P1

Power supply control

R / P

Reset / Programming (used for firmware updates)

DS 1 / DS 2

2 DIP switch blocks with 8 DIP switches each

- 1.1 – 230V power failure
- 1.2 – Momentary action CLOSE (comfort ventilation)
- 1.3 – Momentary action OPEN (comfort ventilation)
- 1.4 – System fault triggers alarm
- 1.5 – VdS triggering by alarm
- 1.6 – Smoke detector – CLOSE (primarily used in Switzerland)
- 1.7 – 24V / 48V input active (primarily used in France)
- 1.8 – Actuators with higher run time than 61sec (both closing and opening speed)
- 2.1 – Run time limitation (comfort ventilation)
- 2.2 – Run time limitation (comfort ventilation)
- 2.3 – Run time limitation (comfort ventilation)
- 2.4 – Re-activation of run time limitation (OPEN)
- 2.5 – 20A on output X1
- 2.6 – Simple cable monitoring
- 2.7 – No grace timer
- 2.8 – Disable low stand-by power

See section 11 for further detail

LED	<u>Shows the status of the panel</u> Red = alarm Yellow = fault Green fast flickering = all OK (CPU working), Green constant = CPU communication stopped (possible reset or contact WindowMaster)
↓ ↑	Close / open all windows. When pressed together right after power has been connected the panel configures / registers connected components.
BH1	vBAT, back-up battery for CPU and system clock The VBAT battery is a 3V lithium coin cell battery, which keeps the CPU and system clock running in case of total power failure (both mains and mains backup battery failure). If VBAT voltage drops below 1.65 V the diodes will indicate an error and the battery must be replaced. vBAT type: 1 pcs. Lithium CR 1220 3V

11 DIP switch configuration

For easy configuration of the smoke panel the Standard version includes 16 DIP switches. The factory settings for all the DIP switches is OFF.

DIP switch	Description on the panel	Description	DIP switch position	Possible consequence
1.1	No 230V Close	230V power failure	ON: The windows close in case of power failure. OFF: No change in position in case of power failure.	This function becomes suspended when DIP switch 1.2 is ON.
1.2	Moment. act. (Totmann) Close	Momentary action CLOSE (comfort ventilation)	ON: The window actuators run for as long as the comfort keypad is pressed. OFF: The windows close completely when pressing the comfort keypad once.	This function becomes suspended when DIP switch 1.1 is on.
1.3	Moment. act. (Totmann) Open	Momentary action OPEN (comfort ventilation)	ON: The window actuators run for as long as the comfort keypad is pressed. OFF: The windows open completely when pressing the comfort keypad once.	
1.4	Error Alarm	System fault triggers alarm	ON: In case of fault (yellow diode lights), the system will go into Alarm and the windows will open. OFF: Only fault indication	
1.5	Re-triggering (VdS)	VdS triggering by alarm	ON: when the alarm is triggered the actuators will, in accordance with VdS 2581, for a duration of 30min be triggered to shortly reverse and open every second minute. OFF: Normal alarm	
1.6	Smoke detc. (B) Close	Smoke detector – CLOSE (primarily used in Switzerland)	ON: When the alarm is triggered by a smoke detector, the windows will close in all smoke zones. A following operation of a break glass unit will leave the system in alarm but trigger the actuators to open the windows. Break glass units have higher priority than smoke detectors. OFF: regardless if the alarm is triggered by smoke detectors or break glass units, the window actuators will open the windows	
1.7	24/48V	24V / 48V input active (primarily used in France)	ON: The 24V / 48V input becomes active. Only <u>one</u> smoke zone is possible. OFF: the 24V / 48V input is deactive. Up to 2 smoke zones are possible.	
1.8	Actuator 180 sec.	Actuators with higher run time than 61sec (both closing and opening time)	ON: The panel will leave actuator voltage on for 180 sec. Used for non EN 12101-2 actuators. OFF: Used with actuators with a run time of less than 60 sec (normal)	

DIP switch	Description on the panel	Description	DIP switch position	Possible consequence			
2.1- 2.3	Run time limit 1 Run time limit 2 Run time limit 3	Run time limitation (OPEN) (comfort ventilation)	The opening run time of the window actuators can be limited via the DIP switch 2.1 - 2.3.	When using 24V DC actuators, a full close cycle must be carried out (2 x run time ca. 120 sec.). Activated by pressing the "Close all windows" button and wait for min 2min. This resets the current position.			
			DIP switch				
			Run time		2.1	2.2	2.3
			No run time limitation (normal)		OFF	OFF	OFF
			83% (~ 50sec)		ON	OFF	OFF
			67% (~ 40sec)		OFF	ON	OFF
			50% (~ 30sec)		ON	ON	OFF
			42% (~ 25sec)		OFF	OFF	ON
			33% (~ 20sec)		ON	OFF	ON
25% (~ 15sec)	OFF	ON	ON				
17% (~ 10sec)	ON	ON	ON				
2.4	Run time re-activate	Re-activation of run time limitation (OPEN)	ON: If DIP switch 2.1 - 2.3 is activated, the run time limitation can be reactivated. OFF: normal	If DIP switch 2.1 - 2.3 is not activated, there is no function on DIP switch 2.4.			
2.5	20A on X1	20A actuator output on X1	ON: actuator output X1 is 20A and actuator output X2 is 10A. The max total output must not exceed 20A. OFF: both actuator outputs (X1 & X2) are 10A				
2.6	Simple cable monitoring	Type of motor line cable monitoring.	ON: simple monitoring. Short circuit between all wires or cable break is detected. OFF: Full monitoring. Short circuit between any of the wires and break of any of the wires is detected.				
2.7	No grace timer	Deactivate grace timer (manual operation after an safety command)	ON: Deactivate grace timer OFF: Use standard grace timer 30 sec. (default) The grace timer is a safety feature that gives the user the possibility to interfere with automatic (non smoke) safety commands for 30 sec. After the 30 sec. has ran out the actuator will return to the automatic position. Smoke commands (Alarm/Reset) always has first priority.				
2.8	Disable low stand-by power	Disalbes low power consumption	ON: Low power mode is disable. Main power supply is kept on. OFF: Low power mode is enabled. Main power shuts off, but turns on every 90sec due to cable monitoring.				

12 Back-up batteries

Connect 2 pcs. back-up batteries type WSC 007 for WSC 310 and type WSA 012 for WSC 320.

See section 17 "Maintenance" for further information.

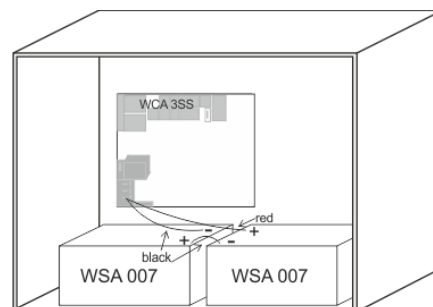

Example of WSC 310 panel with back-up batteries.

13 Configuration of panel

The smoke panel is configured by pressing the two keys "↑" and "↓" on the main card, at the same time for 5-10 seconds. The smoke panel must be configured

- After re-installation, changes, or change of actuators
- When / if MotorLink® actuators are connected
- If the cables have been moved
- When components are removed from the panel
- If there has been a fault on the WSK-Link™. Error blink sequence 6, see section 14.

Note, during reconfiguration both actuator outputs can be activated in both directions.

If the yellow diode on the main card blinks after a configuration, an error has occurred in the configuration, see section "Fault detection via LED" for identification of errors.

13.1 Motor lines – motor groups – smoke zones

All the components connected to the Standard panel are automatically assigned to groups and zones:

- motor lines are assigned to motor groups
- motor groups are assigned to smoke zones
- break glass units and smoke detectors are assigned to smoke zones
- keypads are assigned to one or more motor groups (via hard wiring)

13.1.1 Assigned components per smoke zone

The number of used inputs for break glass units (X5 and X6) determines the number of smoke zones. If break glass units are only connected to one of the inputs (X5), the systems will only have one smoke zone, whereas if break glass units are connected to both inputs the system will have 2 smoke zones.

In case of 2 smoke zones, the connected components are assigned to the two smoke zones as shown in table below.

Connected components	Smoke zone 1	Smoke zone 2
Actuators connected to actuator output X1	X	
Actuators connected to actuator output X2		X
Comfort keypads connected to input X3*	X	
Comfort keypads connected to input X4*		X
Break glass units connected to input X5**	X	
Break glass units connected to input X6**		X
Smoke detectors connected to input X7***		

* will always only control motorline 1 (X3) respectively 2 (X4). One comfort keypad can be connected to both X3 and X4 for control of both outputs.

** comfort keypads and smoke detectors belong to the same smoke zone as the break glass unit they are connected to.

*** both smoke zones will be triggered by these smoke detectors.

If a rain/rain-wind sensor is connected to X10, the safety commands are sent to both smoke zones.

13.1.2 Examples with motor lines / motor groups / smoke zones

- 2 motor lines: one or more actuators connected to the lines
- 2 motor groups: the actuators in the motor group are operated simultaneously on the keypad
- 2 smoke zones: the actuators in the smoke zone are operated simultaneously on the break glass unit

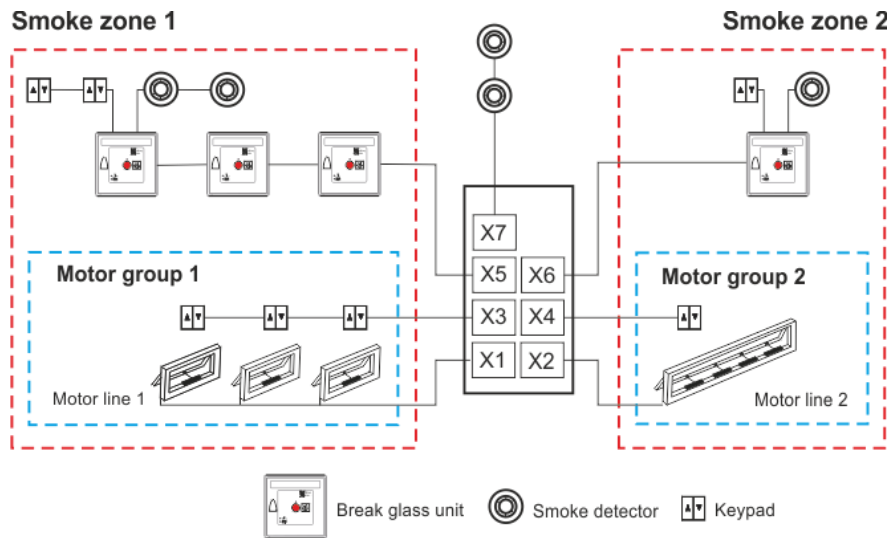

13.1.3 Motor line

Actuators are to be connected on the motor lines. $\pm 24V$ standard actuators and actuators with MotorLink[®] can be connected to all motor lines, but a motor line can only be connected to one type of actuators – either $\pm 24V$ standard or MotorLink[®] actuators. The panel will automatically detect the type of actuator, which is connected to the panel.

13.1.4 Smoke zone

Depending on the settings on the DIP-switches the actuators will either open or close when the smoke panel is triggered, see section 11.

13.1.5 Local input

The seven inputs on the Standard version panels are pre-configured with the functions as shown below.

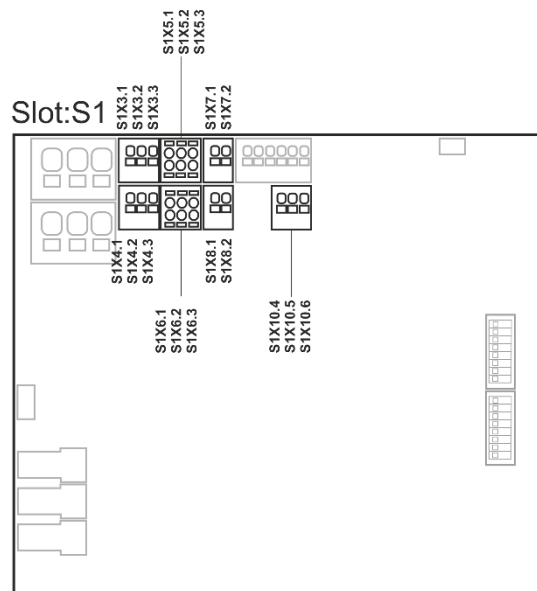

Inputs on the smoke ventilation panel

- S1 X3 – X4 Comfort keypads configuration
- S1 X5 – X6 Break glass units configuration
- S1 X7 Smoke detector configuration
- S1 X8 24V / 48V configuration
- S1 X10 Weather station with wind direction configuration (only possible with the Plus version)

13.1.6 Local output

The output on the Standard version panels are pre-configured with the functions as shown below.

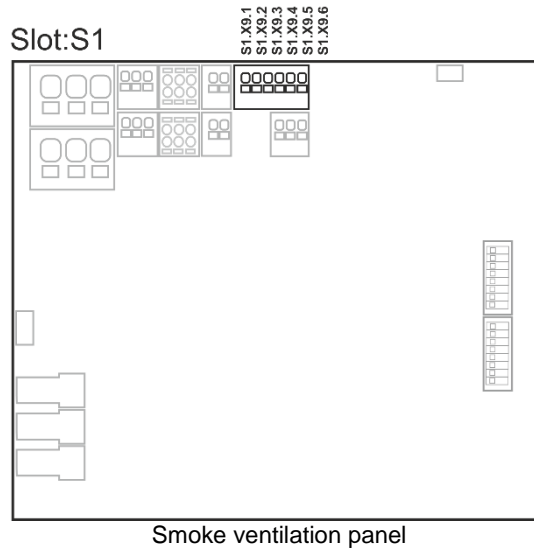

- S1 X9.1 – X9.2 Fault signal to fire alarm system configuration
- S1 X9.3 – X9.4 Alarm triggering in smoke zone 1 configuration
- S1 X9.5 – X9.6 Alarm triggering in smoke zone 2 configuration

14 Fault detection via LED

14.1 Fault detection on the smoke panel

In case of error on the panel, the yellow diode on the main card will blink and via blink sequence indicate an error message. Depending on the type of error message will consist of 2 or 3 blink sequences, separated by a seconds pause. The first blink in an error message has a duration of one second, and thereby indicating when the error message (1st blink sequence) begins. The remaining blinks of the error message has a duration of 0.5 seconds. The error message is repeated until the error has been rectified. Between 2 error messages there is a pause of 2 sec.

Example of an error message

"7 blinks – 1sec. pause – 2 blinks – 1 sec. pause – 1 blinks".

1. There is an error on a local input
2. The error is on input X10.5, to which a rain sensor might be connected
3. The error is due to no connection to the sensor.

If there are more errors on the panel simultaneously, they are shown with priority, i.e. the error message for the most critical error is shown first and repeated until rectified. Then the error message number 2 is shown and repeated as well until the error is rectified etc.

Below table, list the most common errors.

Error message					
1. Blink sequence		2. Blink sequence		3. Blink sequence	
Number of blink	Error on	Number of blink	Error on or error type	Number of blink	Error type
1	System	1	Internal error (Watchdog reset)		
		2	Internal error (Program CRC)		
3	Smoke zone	1	Max temp. in the panel has been exceeded – re-configure and check the panel, see section 13 for re-configuration of the smoke panel		

Error message								
1. Blink sequence		2. Blink sequence		3. Blink sequence				
Number of blink	Error on	Number of blink	Error on or error type	Number of blink	Error type			
5	Actuator	1	X1 (actuator output)	1	Actuator configuration – check the actuators, check the configuration, when using $\pm 24V$ standard actuators check the termination			
				2	Expected number of actuators, the found and expected number of MotorLink [®] actuators does not match – check actuator connections			
				4	Internal error			
		2	X2 (actuator output)	1	Actuator configuration – check the actuators, check the configuration, when using $\pm 24V$ standard actuators check the termination			
				2	Expected number of actuators, the found and expected number of MotorLink [®] actuators does not match – check actuator connections			
				4	Internal error			
6	WSK-Link™	1	Bus	1	Closed ring – the standard version does not allow break glass units connected in a closed ring, check connection of break glass units and disconnect the ring and re-configure			
				2	Problem on X5 (break glass unit) – communication with the break glass unit cannot be established			
				3	Problem on X6 (break glass unit) – communication with the break glass unit cannot be established			
		2	WSK	1	Problem (short circuit, cable problem or termination) with break glass unit #2 connected to a break glass unit– check connection of break glass unit and termination smoke detector input			
				2	Slave panel – the standard version does not allow connection of a slave panel. Remove the slave panel and re-configure			
				3	Offline break glass unit, one or more break glass are offline – check and re-configure			
	1	Local input	1	X7 (smoke detector)	1	Termination – check connection of detectors as well as termination		
					2	X10.5 (rain sensor)	1	Termination – check connection of sensor as well as termination
							1	Termination – check connection of sensor as well as termination
					10	Power supply	1	Internal error
2	Mains – check connection	1	Mains – check connection					
		1	Back-up batteries – check connection or replace the batteries					
3	Back-up batteries – check connection or replace the batteries	1	Back-up batteries – check connection or replace the batteries					
		1	Max temp. in the panel has been exceeded – re-configure and check the panel, see section 13 for re-configuration of the smoke panel					
4	Internal error	1	Internal error					
5	Lithium battery, low voltage	1	Lithium battery, low voltage					

If other errors or an “Internal error” are indicated, please contact WindowMaster.

14.2 Fault indication on break glass unit

If the smoke panel loses the mains connection (230V), the green LED on the break glass unit (WSK 501 / 502 / 503 / 504) will flash. The green LED will flash until the system goes into alarm (check power supply (error message 10.2)).

With the standard settings it can take up to 10min before the loss of connection is registered.

15 Hardware error

If there are any hardware error on the panel it will be indicated by the diodes (yellow diode is lit).

15.1 Error on the Power supply

Mains power failure will trigger an error. Within the first minute after the failure has been detected, the green LED in the break glass unit will start to blink. After 30 minutes (parameter setting), the error is indicated via LED blink sequence, see "Fault detection on the smoke panel", and the windows will close.

Furthermore, non connected, wrong connected or "dead" batteries can trigger an error on the "Power supply".

15.1.1 Blown fuse – 20A fast

Additionally, an error on the "Battery status" can also be triggered if the fuse (20A fast) is blown.

The fuse is located in the bottom left corner of the main card.

20A Fast fuse
Location of 20A fast fuse

15.1.2 Voltage drop on the vBAT and replacement

If VBAT voltage drops below 1.65 V the diodes will indicate error "10 – 6" and the battery must be replaced.

vBAT type: 1 pcs. Lithium CR 1220 3V

Replacement:

1. The vBAT battery is located on the main PCB.
2. Turn off 230 V mains and remove 20A backup battery fuse.
3. Remove the main PCB plastic cover by unscrewing the 4 fixing screws
4. Remove the button cell battery by inserting a small screwdriver in the right side of the vBAT. Press firmly to the left and lift.
5. Insert the new battery with the plus side upwards, slide it in on the left side of the holder and press down. Put the plastic cover back.
6. Reconnect all power supplies.

Location of vBAT

16 Commissioning and test run

In case of hardware error please see chapter 14 "Hardware error". To configure the smoke panel press „↑“ and „↓“ (on the main card) at the same time for 5-10 seconds, see section 13.

The break glass unit WSK 50x will only give an acoustic fault signal if the door on the break glass unit is closed or if the door contact on the break glass unit is pressed.

We recommend that the software of the panel is updated during the annual maintenance check!

We recommend that the commissioning of the smoke panel should be done by a competent smoke ventilation controls installer.

16.1 The control ventilation panel is completely installed, without the operating voltage applied

- a) Check all mechanical and electrical components for damage.
- b) Check all screw and plug connections for tightness and/or firm seating
- c) Check that all external components are installed:
 - 1) $\pm 24V$ actuators: Is the motor end module inserted in the last or only actuator?
 - 2) Automatic smoke detectors: Is the passive end module inserted in the last or only smoke detector?

16.2 With mains voltage, without accumulator

Adhere to the relevant regulations!

Connect the mains cables and reapply the mains voltage.

16.3 With mains voltage, with accumulator

- a) Remove the protection film from one face of the supplied foam rubber. Glue each foam rubber to the bottom side of the accumulators. Connect the accumulators to the black accumulator bridge according to the wiring diagram, then connect the red and the black connection cable to the red and the black flat plug. Remove the bottom protection film of the foam rubber and insert the batteries in the smoke ventilation panel according to section 11, and firmly press down to the housing bottom!
- b) Plug the red connection cable to the + and the black connection to the flat plug of the control panel.
Note: Check correct polarity!

16.4 Ventilation keypad

Closely observe the actuators during opening and closing. They must not be impaired in any position by the building structure. Observe that the actuator cables are not being subject to pulling or pinching.

Check each ventilation keypad individually.

16.5 Break glass unit WSK 50x

- a) Open the door and press the red Open button. The actuators move open through to the end position. The red alarm LED (also in the control panel) is ON; at the same time a permanent acoustic signal sounds (door contact on the break glass unit is pressed!).
- b) Press the Reset/Closed button in the break glass unit. The actuators close through to the end position. The comfort ventilation function is released again. The red alarm LED (also in the smoke ventilation panel) and the acoustic smoke alarm are turned off.

16.6 Smoke detectors

- a) Spray test aerosol on the smoke detectors (aerosol item no. 9549).
- b) The actuators move open through to the end position. The red LED in the smoke detector, the red alarm LED (also in the smoke ventilation panel) and the permanent acoustic signal in the break glass unit are ON.
- c) Press the Reset/Closed button in the break glass unit - the actuators close through to the end position. The comfort ventilation function is released again. The red alarm LED in the break glass unit and in the smoke control panel as well as the acoustic smoke alarm are turned off.

16.7 Emergency power supply test

- a) Remove the mains fuse from the smoke ventilation panel. Wait 10 minutes (or run the actuators shortly). See also national guidelines.
- b) When a mains error have occurred the green LED in the break glass units will flash for 10 minutes. The green LED on the WCA 3SS card in the smoke ventilation panel is still on and the yellow LED is turned off.
- c) After 10 minutes the green LEDs will turn off and all the yellow LEDs in the smoke ventilation panel and the break glass units will lit continuously.
- d) Check that the comfort ventilation keypads are deactivated.
- e) Check that the break glass units are working (section 15.5)
- f) Refit the mains fuse.
- g) The green mains and operating LED's are on, the yellow LED is off, the malfunction message at the break glass unit is off.

16.8 Wind/rain detector

- a) Open the actuators with the comfort ventilation keypads.
- b) Wet the rain sensor, the actuators will fully close.
- c) While the actuators are running, press the Open button at the keypad. The actuators must neither open nor stop!
Exception: If a manual override time (Man. operation after auto comm.).
- d) Any smoke and heat extraction signal will always take priority over the wind/rain signal.
- e) While the rain sensor is active (wet) the smoke ventilation panel is activated (alarm) and the actuators move open through to the end position (alternatively to the SHE position)

If the start-up was successful, close the doors of the break glass units and of the smoke ventilation panel.

If the start-up was unsuccessful (error with one of the test run processes), please see chapter 10 "Description of cards".

If necessary, check the wiring in accordance with the cable plan – see chapter 9 "Cable plan for connection to WSC 3xx".

17 Maintenance

The panels of the smoke and heat exhaust ventilation system have to be checked, serviced and, if necessary, repaired at least once per year by the manufacturer or an authorized partner

Remove all soiling from the units of the smoke and heat exhaust system. Check fastening and clamping screws for firm seating. Carry out a test run of the entire system (see chapter 15 'Commissioning and test run').

Only have defective units repaired in our factory. Only install original spare parts.

Check the operational condition at regular intervals. We recommend a WindowMaster service contract is taken out to ensure the right function of the smoke and heat exhaust system.

All back up batteries coming with the smoke control panel as standard; have to be subjected to regular checks.

The smoke ventilation panel will signal fault on the batteries if the battery voltage is below 17V.

Within the framework of the service, they have to be replaced after the specified **maximum 4** year operating period.

Dispose of used batteries according to the National regulation.

CAUTION: RISK OF EXPLOSION IF BATTERIES ARE REPLACED BY AN INCORRECT TYPE.

We recommend that the software of the panel is updated during the annual maintenance check!

The expected minimum lifetime for the CompactSmoke™ is 10 years excluding the batteries.

17.1 Maintenance agreements

Be aware that regular inspection of smoke ventilation systems is a legal requirement. The legislation requires that the smoke ventilation system's owner inspects and tests the system once every year.

WindowMaster offer maintenance agreements for the smoke ventilation system and every year we inspect the complete system to ensure it complies with the applicable legislation. Maintenance of the smoke ventilation system includes checking windows, window actuators and emergency power and checking that triggering and control functions are fully functional.

Contact our service department for further information: **telephone +44 1536 510990 or info@windowmaster.co.uk**

17.2 Replacement 3SS card

1. Disconnect the 230 V and the batteries.
2. Insert the 3SS replacement card.
3. Turn on the 230 V and connect the batteries.
4. The system will be ready again after approx. 2 seconds.

18 Declaration of Conformity and Declaration of Performance

The smoke ventilation panels are manufactured and tested accordingly to the European requirements.

The total system is not to be put into service until a declaration of conformity for the total system has been made.

The "Declaration of Conformity" and the EN certificate are supplied with panel as separate documents.