

WSC 304 6102

Smoke control unit

Operating manual / Technical information



Table of contents:

- Safety information
- Operating elements and fuse review
- Technical data
- Installation
- Cable lengths table
- Cable plan
- Standard wiring diagram
- Various wiring diagrams
- Commissioning
- Maintenance

www.WindowMaster.com

WindowMaster A/S Skelstedet 13 2950 Vedbæk **Danmark** Tel.: +45 4567 0300 Fax: +45 4567 0390

WindowMaster GmbH Hellerweg 180 32052 Herford **Deutschland** Tel.: +49 (0) 5221 6940 500 Fax: +49 (0) 5221 6940 610

WindowMaster Control Systems Ltd. UNIT 21 Port Tunnel Business Park Dublin 17 **Ireland** Tel: +353 (0) 1894 1444 Fax: +44 (0) 1536 526321

WindowMaster AG Industriestrasse 7 4632 Trimbach **Schweiz** Tel.: +41 (0) 62 289 22 22 Fax: +41 (0) 62 289 22 20

WindowMaster Control Systems Ltd. Kettering Parkway Wellingborough Road Kettering Northants NN15 6XR **United Kingdom** Tel.: +44 (0) 1536 510990 Fax: +44 (0) 1536 526321

Safety information

Attention!

Adherence to the following information is mandatory:

Only allow correspondingly trained, qualified and skilled personnel to carry out installation work.

Reliable operation and the avoidance of damage and hazards is only guaranteed if installation and settings are carried out carefully in accordance with these instructions.

Check the technical data on the system plate.

Hazards to persons ensuing from flaps and wings operated by electric motors.

The forces occurring in the automatic mode can be such that parts of the body could get crushed. When opened, actuators could protrude into the room. For this reason, measures have to be taken prior to starting up the actuators which exclude the danger of injury.

With wings tilting inwards or outwards, the wing must be protected from hinging down once the actuator is unhooked (e.g. for window cleaning). For safety reasons we recommend the use of catching shears.

In the event that wings or flaps are subjected to high wind loads, we recommend to connect the central control unit to a wind detector which will automatically close the flaps.

The fastening methods are exclusively intended for the intended use for which they are designed. The manufacturer does not assume any liability for possible damage resulting from inappropriate use.

230V AC dangerous voltage

Can cause death, severe injury or considerable damage to assets.

The connection of the control system is reserved for qualified personnel.

Disconnect all poles of the unit from the supply voltage prior to opening, installation or assembling. Adhere to the national regulations.

Field of application

The central control system is exclusively designed for the automatic closing of smoke extraction systems, windows, flaps or doors.

Always check that your system meets the valid regulations.

Pay particular attention to the opening cross section, the opening time and opening speed. The cable cross sections depend on the cable length and current consumption (amperage).

Maintenance work

Where devices are used in smoke and heat extraction systems, ensure that they are checked, maintained and, if necessary, repaired at least once per year.

Remove all soiling from the devices, check the fastening and clamping screws for firm seating. Trial run the entire system. Defective devices may only be repaired in our factory. Only use original spare parts.

The supplied accumulators are subject to regular checks and must be replaced every 4 years.

Cable routing and electrical connection

Fuse the 230V AC power supply cable separately on site. **Leave the insulation of the power supply cable in place up to the mains terminal.**

Adhere to the DIN and VDE regulations (Germany) or equivalent in your country.

Establish the cable types, if necessary, with the local approval bodies or the fire protection authority.

Do not conceal flexible cables. Junction box must be accessible for maintenance purposes.

Disconnect all poles of the mains voltage and the accumulators prior to starting maintenance work or making changes to the system.

Secure the system to prevent unintentional switching on again.

Design cable types, lengths and cross sections in accordance with the technical information.

Route all low voltage cables (24V DC) separate from the power current cables.

Manufacturer's declaration

The devices have been inspected and manufactured in accordance with the European directives.

A corresponding manufacturer's declaration is available.

You are only authorised to use the devices if a conformity declaration is issued for the entire system.

Operating elements and fuse review

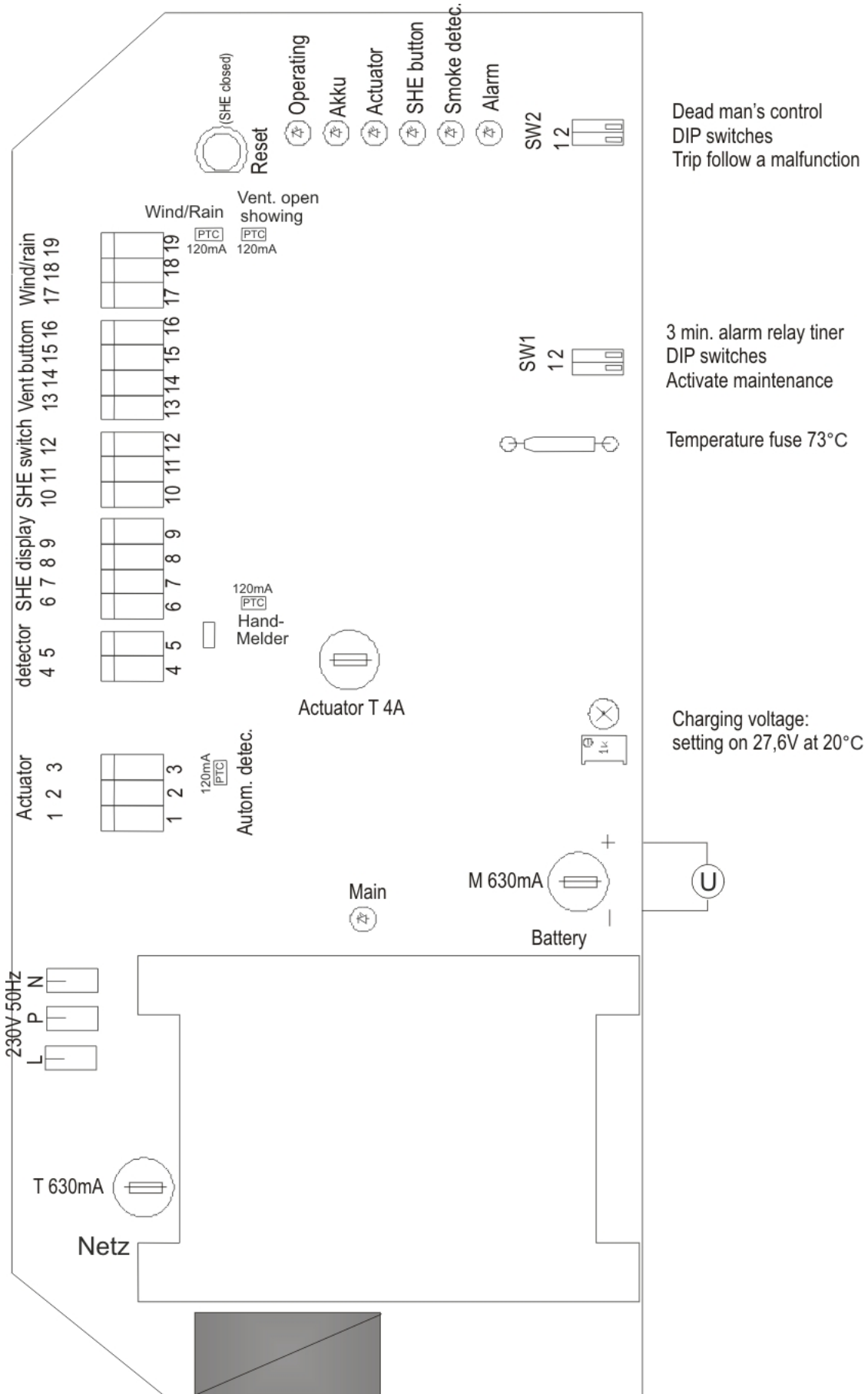

Technical data

Smoke and heat extraction system alarm trip:

The acoustic signal will only sound in the break glass unit if the door is closed or if the door contact switch is pressed.

Break glass unit::

Break the glass in the break glass unit! Press the red button min. 0,5 sec.. The smoke extraction opens.

An acoustic alarm signal sounds (continuous sound) in the break glass unit.

All ventilation functions are out of operation.

Display: The red alarm LED in the smoke control unit and the red LED in the break glass unit are lit.

Smoke detector:

If smoke develops, the smoke extraction system automatically opens.

An acoustic alarm signal sounds (continuous sound) in the break glass unit.

All ventilation functions are out of operation.

Display: The red alarm LED in the smoke control unit, the red LED in the break glass unit, and the red LED at the tripped automatic detector are lit.

Reopening the actuators

The first 30 min. after a SHE-trip the actuators will be cyclically activated every 2 min in OPEN direction (to loosen frost fastened windows, domes e.g.).

Resetting a tripped smoke control unit:

Press the „CLOSE button“ in the break glass unit or the „Reset button“ in the smoke control unit.

The acoustic alarm signal in the break glass unit stops sounding.

The ventilation functions are operational again once the smoke extraction system has closed.

(Prior to resetting, blow out or replace the detector after it was tripped by an automatic detector).

Display: The red alarm LED in the smoke control unit, the red LED in the break glass unit, and the red LED at the tripped automatic detector extinguish.

Resetting a trip caused by high temperature:

The smoke extraction system can be closed again by pressing the „Reset button“ in the smoke control unit or the „CLOSE button“ in the break glass unit.

After operating the CLOSE function, an acoustic pulse tone sounds, and the flashing malfunction LED is only displayed in the break glass unit. The green operation LED remains lit as a special fault diagnosis.

Operating the ventilation button, OPEN or STOP will lead to the tripping of another alarm.

Note:

The built-in thermal switch will then be irreversibly destroyed. The smoke control unit has to be returned for checking.

Option: Alarm trip caused by a malfunction signal:

When this function is activated (SW2/1 = ON), the smoke control unit will trip in the event of a motor, smoke detector or break glass unit circuit malfunction. An acoustic alarm signal sounds (continuous sound) in the break glass unit.

If the temperature exceeds 73°C the automatically SHE-alarm will be activated.

An acoustic alarm signal in the smoke control unit will start.

No trip occurs as a result of a malfunction in the mains or battery circuit.

Display: The red alarm LED in the smoke control unit and the red LED in the break glass unit are lit.

The yellow malfunction LED in the break glass unit and the corresponding yellow malfunction LED in the smoke control unit flash.

Option: Accumulative signalling of the alarm or malfunction signal

Module WSA 301:

It is possible to send an alarm or malfunction signal potential free, by plugging in the alarm/malfunction signalling module.

The sending of the alarm can be stopped. If this is done, the yellow LED on the module will lit.

Technical data

Cascading smoke control units:

The smoke control units can be cascaded by a monitored 2 wire connection from the alarm module of the master smoke control unit to the smoke detector input of the slave central panel.

A malfunction in the cascaded smoke control units is detected via the 2 wire BUS cable. The malfunction is only displayed in the corresponding smoke control unit and in the break glass unit connected to the master smoke control unit.:

Ventilation functions:

Ventilation OPEN:

With the dead man's circuit activated (SW2/2 = ON), the actuators only move open for as long as the OPEN button of the ventilation button is kept pressed.

If no dead man's function is activated (SW2/2 = OFF), the actuators open after pressing the OPEN button (self hold).

Display: The ventilation open LED in the ventilation button is lit (only with LED integrated in the button).

Ventilation stop:

The actuators stop when both buttons are pressed.

Display: The ventilation open LED in the ventilation button remains lit (only with LED integrated in the button).

Ventilation closed:

The actuators close after pressing the CLOSED button.

Display: The ventilation open LED in the ventilation button has extinguished (only with LED integrated in the button).

Option: Ventilation time module

Timemodule WSA 303:

Time to be set between 1 and 30 min. Once this time has elapsed, the actuators close after ventilation „OPEN“ or ventilation „STOP“. This function is not operative if the setting potentiometer is on the right-hand stop.

Wind/rain CLOSE:

The actuators close when the wind/rain sensor has tripped (potential free contact in the sensor switches). The ventilation functions are out of operation as long as a tripped situation is pending.

The tripped signal is shown with the green wind/rain LED.

Alarm tripping has 1. priority.

Option: Transmission of the wind/rain signal

Module WSA 302:

The trip signal of the wind/rain sensor can be transmitted potential free to the next smoke control unit.

CLOSE after a power failure:

2 minutes after a power failure actuators opened for natural ventilation will automatically.

In the event of alarm, this function will be out of operation.

General information:

EMC protection:

All inputs and outputs are protected from coupled in interferences.

Short-circuit protection:

All outputs are protected against short-circuit and overload.

Technical data

Connection possibilities:

- | | |
|--|------------------------|
| 1) Actuators with a total power consumption of max. 4A | |
| 2) Smoke detectors, up to 10 pieces in 1 sensor group
Optical smoke detector and/or thermo-differential sensor
and/or heat max. sensor | WSA 300, WSA 310 |
| 3) Break glass units (main), up to 4 per sensor group | WSK 320 000X |
| 4) Break glass units (secondary), up to 15 | WSK 330 000X |
| 5) Ventilation buttons with 'indicator, up to 15,
any number without 'open' indicator | WSK 100 1161 |
| 6) Wind/rain detector with potential free close contact | WLA 330 01, WLA 331 01 |
| 7) SHE activation on potential free
ASV contact in the smoke sensor entrance | WSA 306 install |

Operation / LED diagnose

Pushing the reset button on the circuit board the SHE activation is reset and the actuators closes.

Setting possibilities via slide switch SW1

SW 1/1 = ON	Inspection indication activated
SW 1/1 = OFF	Inspection indication not activated. After activation only a coded deactivation is possible

To show the activation the LED will flash 10 sec. If this time SW1/1 is once again set on OFF, the prioritised activation is cancelled.

After a period of 12 month the inspection indication will be activated: the yellow fault LED in the main break glass unit will flash and the audible fault alarm will sound. The green operating LED will still flash to show that there is no fault. An alarm signal has first priority.

SW 1/2 = ON	Forwarding the alarm signal (WSA 301). After 3 min. it will stop.
SW 1/2 = OFF	Forwarding the alarm signal (WSA 301) as long as the alarm is triggered.

Setting possibilities via slide switch SW2

SW 2/1 = ON Notice	The SHE alarm trips when malfunction signal from actuator, smoke sensor, break glass unit, max. temperature sensor. This setting is NOT approved accordingly to VdS
SW 2/1 = OFF	No SHE alarm tripped when malfunction signal. Malfunction only shown on the LEDs.

SW 2/2 = ON	The actuators only open for as long as the ventilation button is pressed (dead man control)
SW 2/2 = OF	The actuators opens all up when the ventilation buttons is pressed (self hold)

Diagnosis / monitoring in the control unit and fault elimination

LED on the circuit board	Function is OK	Malfunction	Diagnose
Mains (green)	Lit	Off	Check mains voltage and mains fuse
Operation (green)	Lit	Off	Check all functions
Battery/load control (yellow)	Off	Flashes when main failure or when charging voltage is under 26V. Lits when battery no connection, battery fuse defect, Battery voltage under 19V	Check main fuse and charging voltage. Check battery connection. Check battery fuse. Check battery voltage
Motor circuit (yellow)	Off	Flashes when interrupted	Check actuator fuse and actuator end module
Break glass unit (yellow)	Off	Flashes when interrupted. Lits when short circuit.	Check wiring and jumper J1 in the last or only break glass unit.
Smoke detector (yellow)	Off	Flashes when interrupted. Lits when short circuit	Check wiring and the active end module.

Battery and actuator circuit malfunction be about 8 sec. delayed.

Technical data

Operation / LED diagnose

Alarm (red)	Lits when triggered
Wind / rain (green)	Lits when triggered

Battery charge

Charging voltage: 26,5V to 29V. depending on the surrounding temperature.

Charging current: 350mA, current restricted.

Short-circuit monitoring of the connection cables.

Charging voltage disconnected in the event of a short-circuit.

Note

Replace the emergency power batteries every 4 years!

Optional plug-in modules

Multi malfunction warning module (WSA 301):

Multi malfunction warning:

1 x change-over contact (max. load: 60V, 1A) with 3 pole connection terminal for potential free transmission to the BMS / panel etc.

2 pole connection terminal for 2 wire BUS cable for the feedback of malfunctions in cascaded control units to the break glass unit connected to the master smoke control unit.

Alarm message:

1 x change-over contact (max. load: 60V, 1A) with 3 pole connection terminal for potential free transmission to BMS / panel etc., or as monitored 2 wire alarm cable for cascading control centres.

Jumper plugged in J1 = Only for the alarm transmission to the next smoke control unit (cascading).

Jumper plugged in J2 = pot.-free alarm contact (factory setting).

The transmitting can be interrupt. If so, it will be shown by the yellow LED.

Wind/rain relaying module (WSA 302):

1 x change-over contact (max. load: 60V, 1A) with 3 pole connection terminal for potential free transmission of the wind/rain trip.

Ventilation time module (WSA 303):

Automatic closing in the ventilation mode according to pre selected time (1 min. to 30 min.) after ventilation OPEN or STOP was actuated.

Technical data

Supply voltage	230V AC / 50Hz (+10% / -15%)		
Safety transformer	According to EN 61558		
Mains amperage	Max. 100VA		
Motor output voltage			Load at actuator output
			0A
			4A
	Main supply voltage	207V	25V DC
	230V	28V DC	18V DC
	253V	31V DC	21V DC
			24V DC
Emergency power supply batteries	2x 12V / 1,9Ah. Lifetime 4 years.		
Charging unit:	Charging voltage		
	26,5V to 29V		
..... Charging current	350mA, current limited		
Operating duration (emergency power supply)	72 hours if batteries are fully charged (1,9Ah)		
Current load of the actuators	Max. 4A		
Current load of the smoke unit (batteries, surveillance, periphery)	Max. 0,7A		
Switch-on duration	40% ED		
Reopening the actuators	During the first 30 min. after a SHE-trig the actuators cyclically every 2 min.		
Review of fuses	Mains 630mA slow-blow Motor 4 A slow-blow Battery 630mA medium slow-blow		
Type of connection to external	Mains screw terminal / plug-screw terminals / 0.5-2.5qmm		
Cable monitoring	Automatic detectors (detector circuit with active end module), break glass unit (detector circuit with end resistor), actuators (with motor end module), batteries (cyclic measurement)		
Message Alarm trip / malfunction	Optically alternating or steady signals by LED's. Operating and alarm tripping = steady signal. Malfunction of battery, actuator, break glass unit and smoke detector in the event of an interruption = alternating, in the event of a short circuit = steady signal		
Temperature	-5°C - 40°C. Max. 90% relative humidity (not condensing)		
Protection type	IP 30		
Housing	Plastic house type UK 511 with metal door. Build in or surface mounted (with plastic frame). Protection class II. Dimensions (WxHxD) 335x350x95mm. Cut-out dimension hole (WxDxH) 335 x 350 x 95mm. Upgradeable with 1,9Ah to 2,2Ah batteries.		

Installation

Cable routing

Observe the safety information on page 2.

For cable routing we recommend the use of fire protected cables retaining their function E90 or E30.

However, this has to be agreed with the Engineer or, if necessary, with the local fire protection department.

Do not reduce the cable cross sections specified in the cable lengths table.

All cables of the control centre (except the mains supply cable) carry 24V DC and have to be routed separate from the mains supply cable.

Adhere to the pertinent national and local regulations when routing the cables.

Do not use the green/yellow conductor.

Ensure that the mains cable can be switched via an external or customer-supplied two-pole switch element or a switch element controlling all poles.

Smoke unit installation

Note that the control centre has to be installed in a dry room.

Concealed housing
Refer to the sketch below for the installation position

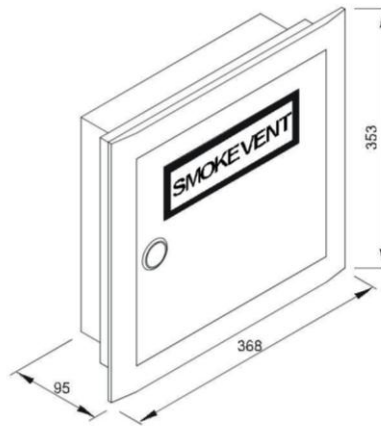

Open central control and remove the housing top section (door) from the housing bottom section.

Fasten the housing bottom section in the wall cut-out (cut-out dimension 335 x 350 x 95) and refit the housing top section.

Also possibility for surface mounting with the included frame.

Installation of the Break glass unit, ventilation buttons and detectors

Ensure that the Break glass unit and the ventilation buttons are visible and well accessible.

Do not install behind protruding walls, door panels or hidden by the building structure.

Note: Installation height of the Break glass unit = 1.4 m above floor.

Install the automatic detectors in accordance with their enclosed instructions.

Installation

Lead the connection cables into the housing of the control centre from above.

All connection terminals (except the mains terminals) are of the plug-in type.

Connect the connection cables in accordance with the terminal plan. Ensure that the connections are made correctly.

Incorrect clamping, mixing up numbers or colours could lead to malfunctions of the central control or of the external components.

Ensure that the electrical cables are always routed according to the valid national and local regulations of the individual country.

Cable lengths table

Maintaining the cable functions

According to valid national regulations.

The cable network for smoke ventilation systems („Cable system“) ends at the interface (junction box) for the actuator!

The flexible, heat resistant connection cable of the smoke ventilation system actuator is part of the system component ‚electric motor actuation‘ and does not belong to the electrical installation!

We recommend in all cases to discuss the type of cable routing with the competent fire fighting authorities.

Cable length table

For determining the maximum permissible cable lengths between the smoke control unit and the actuators, taking into account the specified cables cross sections, please refer to the following table:

Maximum motor current: 4A (**Note:** Be aware of the overall capacity of the smoke control unit!)

Maximum cable length: (always routed from the central smoke control unit to the last junction box)

Actuating current: Sum of all motor currents per group module

Note: Do not use the green/yellow wire!

Per motor supply line, 3 wires are required (2 wires current carrying /1 wire for monitoring)

Cross section	3 wire 1,5 mm ²	5 wire 1,5 mm ² (2 wires in parallel)	3 wire 2,5 mm ²	5 wire 2,5 mm ² (2 wires in parallel)	3 wire 4 mm ²
Actuator current in Amps					
1	84,00 m	168,00 m	140,00 m	280,00 m	224,00 m
2	42,00 m	84,00 m	70,00 m	140,00 m	112,00 m
3	28,00 m	56,00 m	46,67 m	93,33 m	74,67 m
4	21,00 m	42,00 m	35,00 m	70,00 m	56,00 m

(The information is valid for ambient temperatures of 25°C)

Formula for the calculation of the maximum cable length

Permissible max. voltage drop in the line UL : 2 Volt

max. cable length = $\frac{\text{permissible voltage drop (UL)} \times \text{conductivity of copper (56)} \times \text{cable cross section (A)}}{\text{max. actuator current total (I) in amps} \times 2}$

Permissible cable length for the break glass unit supply cable when using.....4x2x0.8mm: **up to 200m**

The motor connection cable length to the junction box (or control module) must not exceed **10 m**.

Standard wiring diagram

Wiring diagram Smoke control unit WSC 304 6102

Attention!
If the direction of the actuator is wrong, please exchange the - and the + wire of the actuator-lead wire.

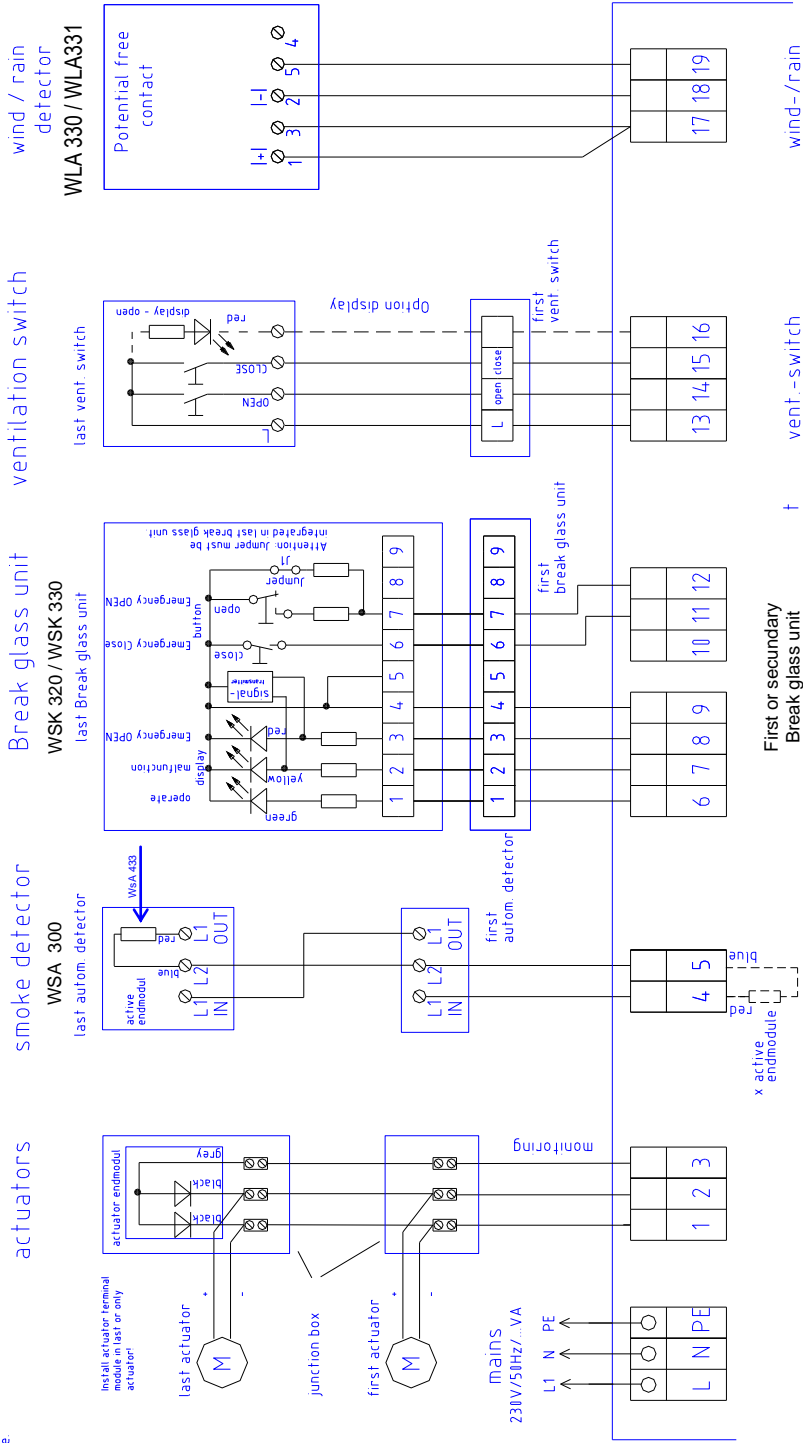

If only one break glass unit – use a main break glass unit.

Attention!
Remove isolation of mains not more than max. 3cm to avoid that cores can get in touch with metal case or other controlling parts!

Attention!
In case of using autom. detectors please remove the endmodule of clamp 4, and clamp 5 and install inside the last or only detector! Active end-module to install only, when no detector is connected!

First or secondary Break glass unit

Various wiring diagrams

Wiring diagram smoke control unit WSC 304 6102 autom. detector WSA 310 / ASV module WSA 306

Thermo detector
WSA 310

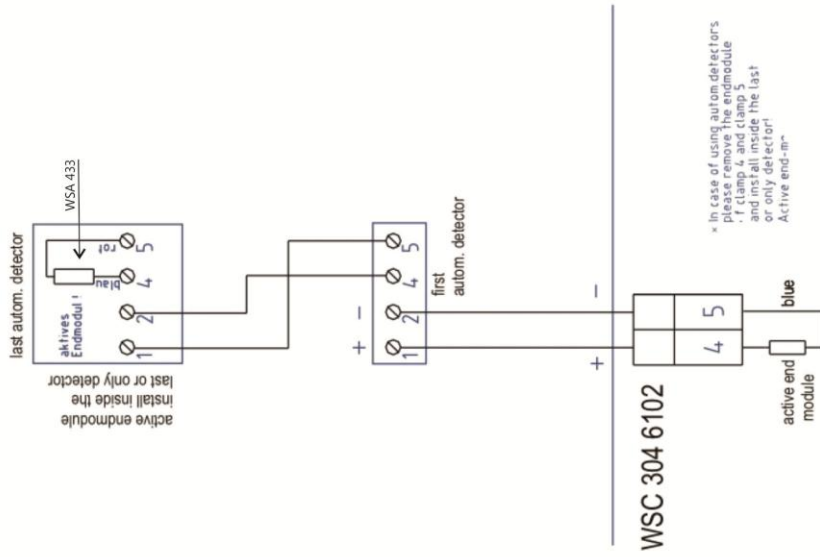

ASV System
WSA 306

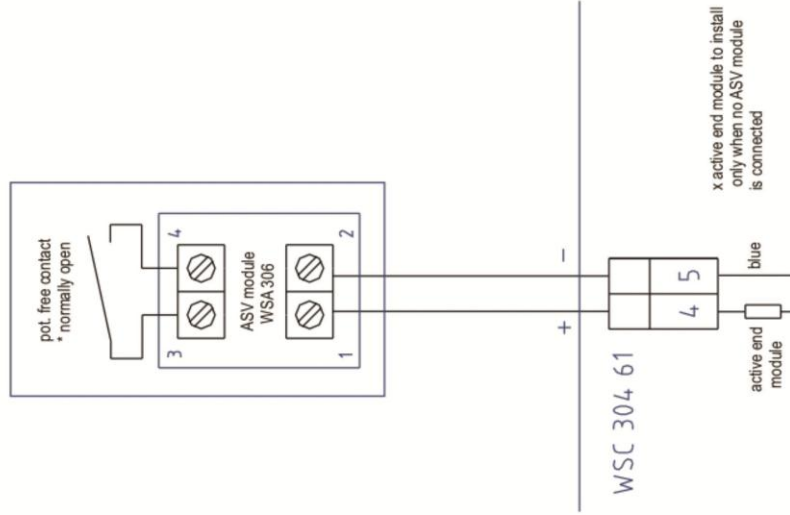

Commissioning

When error message occur, please refer to chapter Operating elements and fuse review.

An acoustic message only occurs in the Break glass unit with the door closed or the door contact switch pressed!

- 1) **The control centre is completely installed, without the operating voltage applied**
 - a) Check all mechanical and electrical components for damage.
 - b) Check the DIP slide switches in the control centre for their correct (required) position.
 - c) Check all screw and plug connections for tightness and/or firm seating.
 - d) Check that all external components are installed.

Actuators:	Is the final module at the last or only actuator inserted?
Automatic detectors:	Is the active end module at the last or only detector inserted?
Manual detectors:	Is the jumper only inserted in the last or only operating panel?

- 2) **With mains voltage, without accumulator**

Adhere to the relevant regulations! Externally disconnect the mains voltage.

 - a) Connect the mains cables and reapply the mains voltage.
 - b) The mains LED is ON, the operating LED is OFF, the accumulator LED is ON. The malfunction message at the operating panels is ON.

- 3) **With mains voltage, with accumulator**
 - a) Remove the protection film of the lateral adhesive tape for the 1.9 Ah battery, and firmly press the two batteries together according to the picture (next page).
 - b) Remove the protection film from one face of the supplied foam rubber. Glue each foam rubber to the bottom side of the accumulators. Connect the accumulators to the black accumulator bridge according to the wiring diagram, then connect the red and the blue connection cable to the red and the black flat plug. Remove the bottom protection film of the foam rubber and insert the batteries in the control unit according to figure 1, and firmly press down to the housing bottom!
 - c) Plug the red connection cable to the + and the blue connection to the flat plug of the control unit. Note: Check correct polarity!
 - d) The operating LED is ON, the accumulator LED is OFF. The malfunction message at the operating panels is OFF.

- 4) **Ventilation button**
 - a) **Closely observe the actuators during opening and closing. They must not be impaired in any position by the building structure. Also the motor connection cables must not be subject to pulling or crushing.**
 - b) Briefly actuate the Open button to have the actuators move open up to the final position. With the SW2/2 =ON (hold-to-run) setting, the actuators only move as long as the button is pressed. The OPEN display (if existing) in the button is ON.
 - c) Briefly actuate the CLOSED button, the actuators close. The Open display is OFF.
 - d) Press both buttons simultaneously while running, this corresponds to stop. The ventilation Open display is ON, the actuators stop.
 - e) Briefly press the Closed button again, the actuators fully close, the Open display is OFF.

- 5) **Break glass unit**
 - a) Open the door and press the red Open button. The actuators move open through to the end position. The red alarm LED (also in the control unit) is ON, at the same time a permanent acoustic signal sounds (door contact pressed!).
 - b) While running, press the Closed button at the ventilation button, then press both buttons, the actuators must neither close nor stop!
 - c) Press the reset/Closed button in the break glass unit. The actuators close through to the end position. The ventilation function is released again. The red alarm LED (also in the control unit) and the signal generator are OFF.

- 6) **Break glass unit (secondary)**
 - a) Check as described under 5). „Operation“, „Malfunction“ and the acoustic signal are missing!

Commissioning

7) Automatic detectors

- a) Spray test aerosol on the detectors.
- b) The actuators move open through to the end position. The red LED in the detector, the red alarm LED (also in the control unit) and the permanent acoustic signal in the operating panel are ON.
- c) While running, press the Closed button at the ventilation button, then press both buttons, the actuators must neither close nor stop!
- d) Press the reset/Closed button in the operating panel. The actuators close through to the end position. The ventilation function is released again. The red alarm LED (also in the control unit) and the signal generator are OFF.

8) Emergency power supply test

- a) Remove the mains fuse from the control centre. Adhere to the relevant regulations!
- b) The green mains and operating LED's are OFF, the yellow accumulator Led is flashing (control unit in the accumulator mode).
The malfunction message at the break glass unit is ON.
- c) The ventilation buttons are deactivated.
- d) If the actuators were open, they will automatically close after 2 minutes.**
- e) Test the SHE trip and reset/closed as described under 5).
- f) Refit the mains fuse.
- g) The green mains and operating LED's are ON, the yellow accumulator LED is OFF. The malfunction message at the break glass units is OFF.

9) Aktivation of internal check

- a) Disconnect the smoke vent unit from the mains and back-up batteries
- b) Exchange the blind jumper J2 for active jumper J1
- c) Reconnect the smoke vent unit to the mains and back-up batteries
- d) The operation LED flashes app. 10 seconds to control the activation

10) Wind/rain detector

- a) Open the actuators with the ventilation button.
- b) Wet the rain sensor, the actuators will fully close, the green wind/rain LED in the control centre is ON.
- c) While running, press the Open button at the ventilation button, then press both buttons, the actuators must neither open nor stop!
- d) The Smoke trip has priority.**

When the start-up was successful, then close the doors of the break glass units and of the control unit.

If the start-up was unsuccessful (error with one of the test run processes), please refer to the chapter **Function description** and **Operating elements and fuse review**. If necessary, check the wiring in accordance with the **wiring diagram**.

Maintenance

The units of the smoke detection and heat extraction system have to be checked, serviced and, if necessary, repaired at least once per year by the manufacturer or an authorised specialist company. We also recommend the above to be carried out for pure ventilation units.

Remove all soiling from the units of the smoke ventilation system. Check fastening and clamping screws for firm seating.

Carry out a test run of the entire system (see chapters Start-up and Test Run).

Only have defective units repaired in our factory. Only install original spare parts.

Check the operational condition at regular intervals.

We recommend to sign a maintenance contract with the manufacturer or an authorised specialist company.

All batteries coming with the smoke control unit as standard, have to be subjected to regular checks.

Within the framework of the service, they have to be replaced after the specified 4 year operating period.

Adhere to the laws governing the disposal of hazardous substances (e.g. batteries).