

Technical information

Thermal-Differential-Detector WSA 310 (Apollo 55000-127)

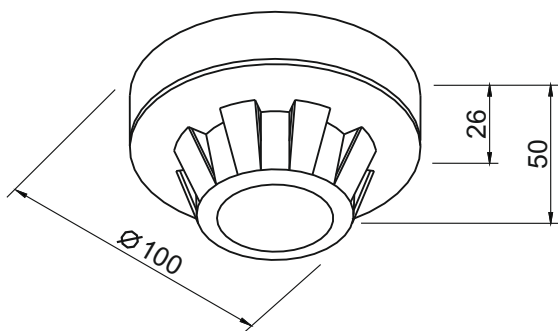

Description:

Thermal-Differential-Detector for early fire detection.
Alarm release in case of fast temperature increase. Max. approx 75°C with visual "release" display, including mounting base.



Approval-
NO.: G200060

Technical data:

Connection voltage: 24V DC
Current consumption (rest): 0,1 mA
Casing: AP-plastic, round, white
Operating temp.: -20° till +90°C

Electrical connection:

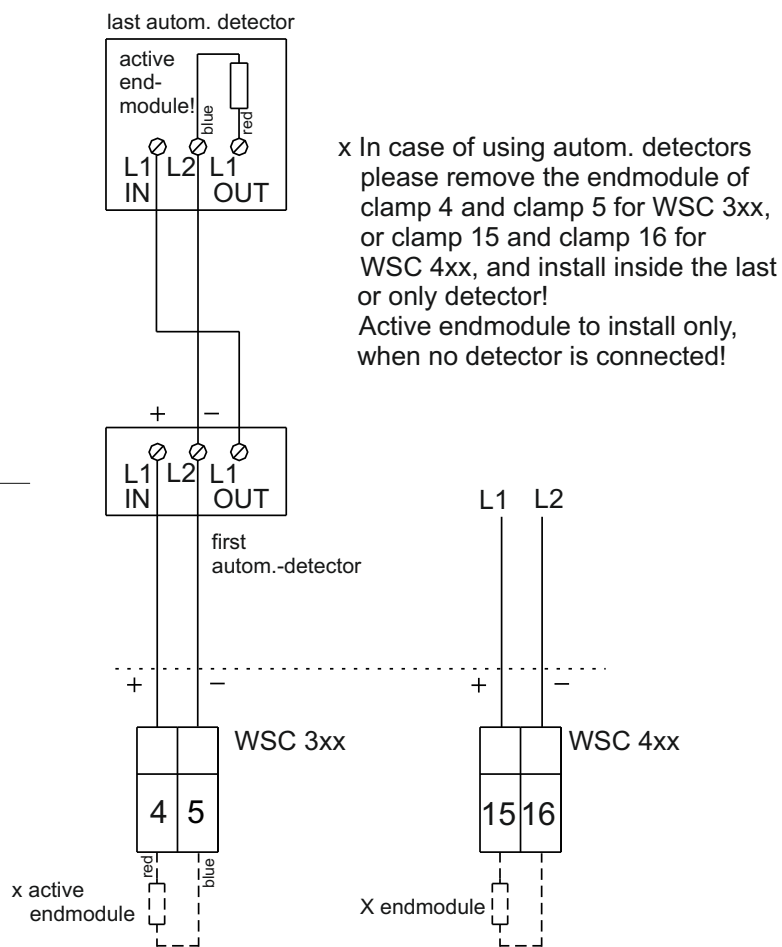
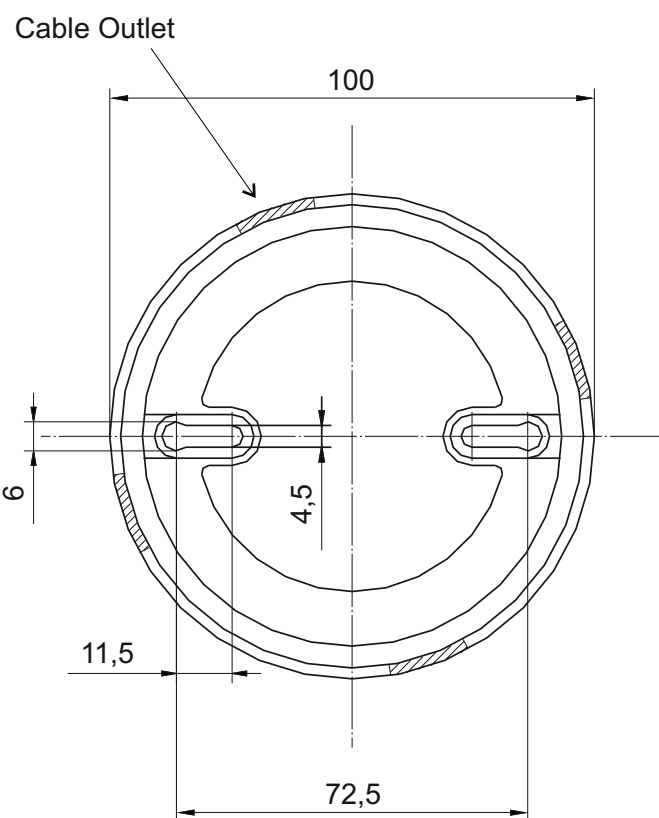

Windowmaster.com

WindowMaster A/S **Danmark** Tel.: +45 4567 0300 Fax: +45 4567 0390
 WindowMaster GmbH **Deutschland** Tel.: +49 (0) 5221 6940 500 Fax: +49 (0) 5221 6940 610
 WindowMaster Control Systems Ltd. **Ireland** Tel.: +353 (0) 1894 1444 Fax: +44 (0) 1536 526321
 WindowMaster AG **Schweiz** Tel.: +41 (0) 62 289 22 22 Fax: +41 (0) 62 289 22 20
 WindowMaster Control Systems Ltd. **United Kingdom** Tel.: +44 (0) 1536 510990 Fax: +44 (0) 1536 526321