

# WCC 103 A

Installation instruction

## MotorController

(Version 2603)



Save this installation manual for the end user  
The latest version of this document can always be found on our website

**UK** +44 1536 614070 info.uk@windowmaster.com  
**Others** +45 45 670 300 info.dk@windowmaster.com

[www.windowmaster.com](http://www.windowmaster.com)

<b>1</b>	<b>Safety regulations</b>	<b>3</b>
1.1	Safety	3
1.2	230V AC	3
1.3	Application	3
1.4	Cabling and electrical connection	3
<b>2</b>	<b>Introduction to WCC 103 A</b>	<b>3</b>
2.1	The MotorController's construction	3
2.2	MotorController variants	4
2.3	Max number of actuators per MotorController	4
<b>3</b>	<b>Accessories</b>	<b>5</b>
<b>4</b>	<b>Technical data</b>	<b>5</b>
<b>5</b>	<b>Mounting</b>	<b>6</b>
<b>6</b>	<b>Installation</b>	<b>6</b>
6.1	Cable routing	6
6.2	Connecting cables in the MotorController	6
6.3	Connecting protective earth and 230V AC	6
6.4	Installation of comfort keypad	6
6.5	Assembly instructions	6
<b>7</b>	<b>Cable dimensioning</b>	<b>7</b>
7.1	Max. cable length	7
7.1.1	Formula for calculating max. actuator cable length	7
7.1.2	Max. cable length – $\pm 24V$ standard actuators	7
<b>8</b>	<b>Connection plan for WCC 103 A</b>	<b>7</b>
<b>9</b>	<b>Connection description</b>	<b>8</b>
<b>10</b>	<b>Control via remote control – WCA 100</b>	<b>11</b>
10.1	Before use	11
10.1.1	Pairing of remote control and MotorController	11
<b>11</b>	<b>Control via app – Fresh Air Control</b>	<b>12</b>
<b>12</b>	<b>Status and troubleshooting via LED on the MotorController</b>	<b>13</b>
<b>13</b>	<b>Commissioning and test run</b>	<b>13</b>
13.1	MotorController fully installed, without operating power	13
13.2	With network power	13
13.3	Remote control and comfort keypad	13
13.4	Wind/rain sensor	14
<b>14</b>	<b>Maintenance</b>	<b>14</b>
14.1	Maintenance agreement	14
<b>15</b>	<b>Components declaration</b>	<b>14</b>

# 1 Safety regulations

## 1.1 Safety

Only allow correspondingly trained, qualified and skilled personnel to carry out installation work.

Reliable operation and the avoidance of damage and hazards are only guaranteed if installation and settings are carried out carefully in accordance with these instructions.

There may be personal danger by electrically operated windows:

- the forces occurring in the automatic mode can be such that parts of the body could get crushed
- when opened, actuators (spindles) could protrude into the room

For this reason, measures must be taken prior to starting up the actuators, which exclude the danger of injury.

For safety reasons we recommend installing opening restrictors on bottom-hung windows.

In the event that windows are subjected to rain and/or high wind loads, we recommend connecting a wind/rain sensor to the MotorController for the automatically closing of the windows.

The MotorController is to be in a safe place, protected from the effects of fire and smoke.

The MotorController is to be surface mounted.

The MotorController is supplied by 230V AC.

The manufacturer does not assume any liability for possible damage resulting from inappropriate use.

## 1.2 230V AC

230V AC can cause death, severe bodily injury, or significant damage to property.

The MotorController must be disconnected from the power supply before being opened, mounted, or performing any alteration of the construction.

Power supply to the MotorController must be done via external two-pole or multi-pole circuit breaker. The MotorController is to be supplied with Phase conductor, Neutral conductor and Earth conductor.

Applicable national regulations must be complied with.

## 1.3 Application

The MotorController is solely designed for the automatic opening and closing of windows, flaps and doors.

Always check that the system complies with applicable national regulations.

The cable cross section will depend on wire length and power consumption. See chapter "Cable dimensioning".

## 1.4 Cabling and electrical connection

WindowMaster recommends powering the MotorController from its own group.

Cable routing and connection - adhere to national regulations.

Establish the cable types, if necessary, with the local approval bodies.

Do not conceal flexible cables.

Junction box must be accessible for maintenance purposes.

Disconnect all poles of the mains voltage prior to starting maintenance work or making changes to the system.

Secure the system to prevent unintentional switching on again.

Route all low voltage cables (24VDC) separate from the power current cables. Design cable types, lengths and cross sections in accordance with the technical information. Cable specifications is a guide only; the overall responsibility resides with the electrical contractor on site. Installation must be in accordance with the national electrical regulations.

# 2 Introduction to WCC 103 A

WCC 103 A is a MotorController that controls (opens/closes) 1 or more  $\pm 24V$  standard window actuators on the basis of a signal from the remote-control type WCA 100, the app "Fresh Air Control", connected comfort keypads or the connected components, e.g. room sensors and weather sensors.

## 2.1 The MotorController's construction

The MotorController contains a 75W primary power supply (SMPS - switched mode power supply) and a printed circuit board with input, output and auxiliary supply (AUX).

WCC 103 A has 1 motor line to which  $\pm 24V$  standard actuators can be connected; the number of connected actuators depends on the actuator type; the following table lists the max number of actuators. Total power consumption for all connected motors incl. load on X7 (AUX max 0.5A) may not, however, exceed 3A.

## 2.2 MotorController variants

Item composing						
WCC 1	03	A		xx	xx	
					<u>Version</u> 01 = version 1 02 = version 2, allows control via app	
					<u>Variant</u> 01 = Standard variant with Schuko plug 04 = UK variant with UK network adapter	
					<u>Communication</u> A = wireless operation via app or remote control	
					<u>MotorController size</u> 03 = 3A	
MotorController series 1						

## 2.3 Max number of actuators per MotorController

The table shows the maximum number of actuators. Total power consumption for all connected actuators incl. load on X7 (AUX max 0.5A) may not exceed 3A.

Only  $\pm 24V$  standard actuators may be connected to WCC 103 A.

Actuator type	Max number $\pm 24V$ actuators that may be connected to WCC 103 A
WMD 820-1	3
WMD 820-2	2
WMD 820-3	3
WMS 306 / 309-1	3
WMS 306 / 309-2	2
WMS 306 / 309-3	3
WMS 409 xxxx	1
WMS 409-1	1
WMU 831 / 851-1	3
WMU 831 / 851-2	2
WMU 831 / 851-3	3
WMU 836-1	2
WMU 836-2	2
WMU 852-1	3
WMU 852-2	2
WMU 852-3	3
WMU 861-1	2
WMU 861-2	2
WMU 842 / 862 / 882-1	1
WMU 863 / 883-1	1
WMX 503 / 504 / 523 / 526-1	6
WMX 503 / 504 / 523 / 526-2	6
WMX 503 / 504 / 523 / 526-3	6
WMX 503 / 504 / 523 / 526-4	4
WMX 803 / 804 / 813 / 814 / 823 / 826-1	3
WMX 803 / 804 / 813 / 814 / 823 / 826-2	2
WMX 803 / 804 / 813 / 814 / 823 / 826-3	3
WML 820 / 825	3
WML 860-1	3
WML 860-2	2
WML 860-3	3

Actuator type	Max number ± 24V actuators that may be connected to WCC 103 A
WMB 801/802	3
WMB 811 / 812 / 815 / 816 / 817 / 818*	2
*with 2 locking actuators on the same motor line use: 1 x WMB 811 and 1 x WMB 812. 1 x WMB 815 and 1 x WMB 816 or 1 x WMB 817 and 1 x WMB 818	

### 3 Accessories

Accessories	
Rain sensor	WLA 331
Rain / windspeed sensor	WLA 330
Comfort keypad, 1 window or 1 window group	WSK 110 0A0B
Comfort keypad, model FUGA, surface mounting (CH version)	WSK 300
Comfort keypad, model FUGA, surface mounting	WSK 103
Room thermostat: temperature	WLA 110

### 4 Technical data

Technical data	
Output current	3A incl. load on X7 (max 0.5A)
Secondary voltage	Voltage 24V DC (±15%) Resting potential with 230V AC without load 24V DC @ 20°C Ripple with full load 150mVp-p
AUX	24V DC, 500mA
Motor groups / Motor lines	1 motor group with 1 motor line for ±24V standard actuators
Primary voltage	100-240 VAC 0.85A 50/60Hz
Power consumption	Idling < 0.5W Full load 77 W
Leakage current	Max 0.75mA @ 240VAC
Inrush current on primary side	65A < 5ms w. 230V Max. 6 x WCC 103 A per 10A power supply group. Circuit breaker "C" type.
±24V	Min. 500ms
LED signalling	2 green LEDs and 1 yellow indicate via blinking sequences failure and/or status of the system and motor line. See paragraph on "Status and troubleshooting via LED" for a detailed description and blinking sequences.
Connection cable	Actuators flexible max. 6mm <sup>2</sup> / solid max. 10 mm <sup>2</sup> Other components min 0.2mm <sup>2</sup> / max. 1.5mm <sup>2</sup>
Operation range between MotorController and remote control	<ul style="list-style-type: none"> <li>- Outside: up to 50m in radius</li> <li>- Inside: up to 10m in radius</li> </ul> Physical barriers such as walls, cabinets etc. will reduce the range.
Operating conditions	-5°C - +45°C, for indoor mounting, the MotorController must not be covered
Max actuator activation duration (duty cycle)	ED 40% (4 min. per 10 min.)
Material	Plastic
Colour	White (RAL 9016)
Size	MotorController: 215 x 206 x 37mm (W x H x D)
Weight	MotorController: 0.92kg
Protection class	IP 20
Safety class	I (with PE)

Delivery	Standard version:	MotorController with 1.2 m cable with Schuko plug
	UK version:	MotorController with 1.2 m cable with Schuko plug and UK network adapter
Note	We reserve the right to make technical changes	

## 5 Mounting

The MotorController may either be mounted horizontally or vertically on a wall.

The MotorController is fixed to the wall through the back plate's  $\varnothing 4.5$  mm mounting holes.

The MotorController should be mounted in a secure location so that it is protected against the effects of fire and smoke.

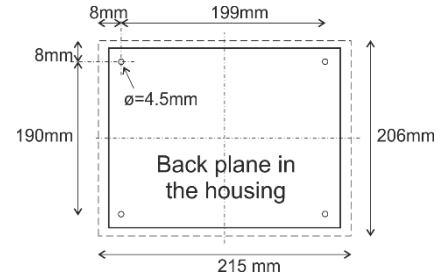

## 6 Installation

### 6.1 Cable routing

The safety regulations in these guidelines must be closely followed. Regarding low power cable configuration, we refer you to the chapter "Cable dimensioning". The cable cross sections listed in the table of cable lengths must not be reduced.

The cables are led into the MotorController's cabinet via cut-outs in the bottom. When routing cables, all applicable national regulations must be complied with. The MotorController is supplied with a 1.2 m cable with Schuko plug.

### 6.2 Connecting cables in the MotorController

Cables are to be connected in accordance with the chapter "Connection plan for WCC 103 A", the short chapters and other relevant paragraphs in these guidelines.

Please ensure that connections are correctly executed - incorrect connection can lead to functional failure in the MotorController or external products.

The installation must always adhere to the applicable regulations, standards and guidelines.

### 6.3 Connecting protective earth and 230V AC

WCC 103 A is factory-fitted with a power supply cable with a 230V Schuko plug with earth wire.

### 6.4 Installation of comfort keypad

Any comfort keypad should be mounted in a visible position and within easy reach.

### 6.5 Assembly instructions

**Always have assembly, installation, repair and maintenance of ventilation systems carried out by qualified personnel trained for this purpose.**

#### Rules to be adhered to for setting up and installation

The following safety relevant rules must be adhered to when planning the use of a ventilation system and its set-up and installation:

- The Provincial Building Ordinance of the provinces

**Accident prevention regulations Adhere to the general accident prevention regulations (APR), the APR for power operated windows and doors, and the installation rules in your country.**

#### Caution:

If internal coverings are removed the live current parts are exposed.

#### Guidelines for mounting / installation

- the MotorController should be mounted on the wall in such a way that there is free access for service inspections
- adhere to the installation instructions and your local energy providers
- select the place of installation such that free access is guaranteed for maintenance purposes
- select cables according to regulations in this instruction - take the calculation of the actuators supply cable lengths into account when laying the cables
- connect the cables in accordance with the drawings provided by the manufacturer
- route the cables in the building according to the regulations in this instruction
- check all system functions

# 7 Cable dimensioning

Cables should be routed in compliance with applicable regulations.

## 7.1 Max. cable length

The maximum permitted cable lengths from the MotorController to the actuators, taking into account the cable cross-section, are shown in the following table.

### 7.1.1 Formula for calculating max. actuator cable length

$$\text{Max. cable length} = \frac{\text{permitted voltage drop } 2V \text{ (UL)} \times \text{copper's conductivity (56)} \times \text{cable cross-section in mm}^2 \text{ (a)}}{\text{Max. total actuator current per motor line in amperes (I)} \times 2}$$

For ±24V standard actuators, the cable cross-section may not be less than 0.75 mm<sup>2</sup>, irrespective of the result of the above formula.

**Maximum actuator cable length:** Always measured from the MotorController to the last junction box + actuator cable

**Permissible max. voltage drop in the line:** 2 Volt

**Total actuator current:** The sum of all the connected actuators max. current consumption per motor line

**Note:** do not use the PE wire / green/yellow wire in the actuator cable!

#### Example

Max. actuator cable length with cable cross-section of 0.75mm<sup>2</sup> and 2A current consumption:  $(2 \times 56 \times 0.75) : (2 \times 2) = \underline{21m}$

### 7.1.2 Max. cable length – ±24V standard actuators

The actuator cable must have 2 wires minimum.

±24V standard actuators						
The PE wire/the green-yellow earth wire must <u>not</u> be used						
Cable-cross-section [a]	3-wire 0.75mm <sup>2</sup>	3-wire 1.50 mm <sup>2</sup>	5-wire 1.50 mm <sup>2</sup> 2-wire parallel	3-wire 2.50 mm <sup>2</sup>	5-wire 2.50 mm <sup>2</sup> 2-wire parallel	3-wire 4.00 mm <sup>2</sup>
Total actuator current [I]						
1A	42m	84m	168m	140m	280m	224m
2A	21m	42m	84m	70m	140m	112m
3A	14m	28m	56m	47m	93m	75m

# 8 Connection plan for WCC 103 A

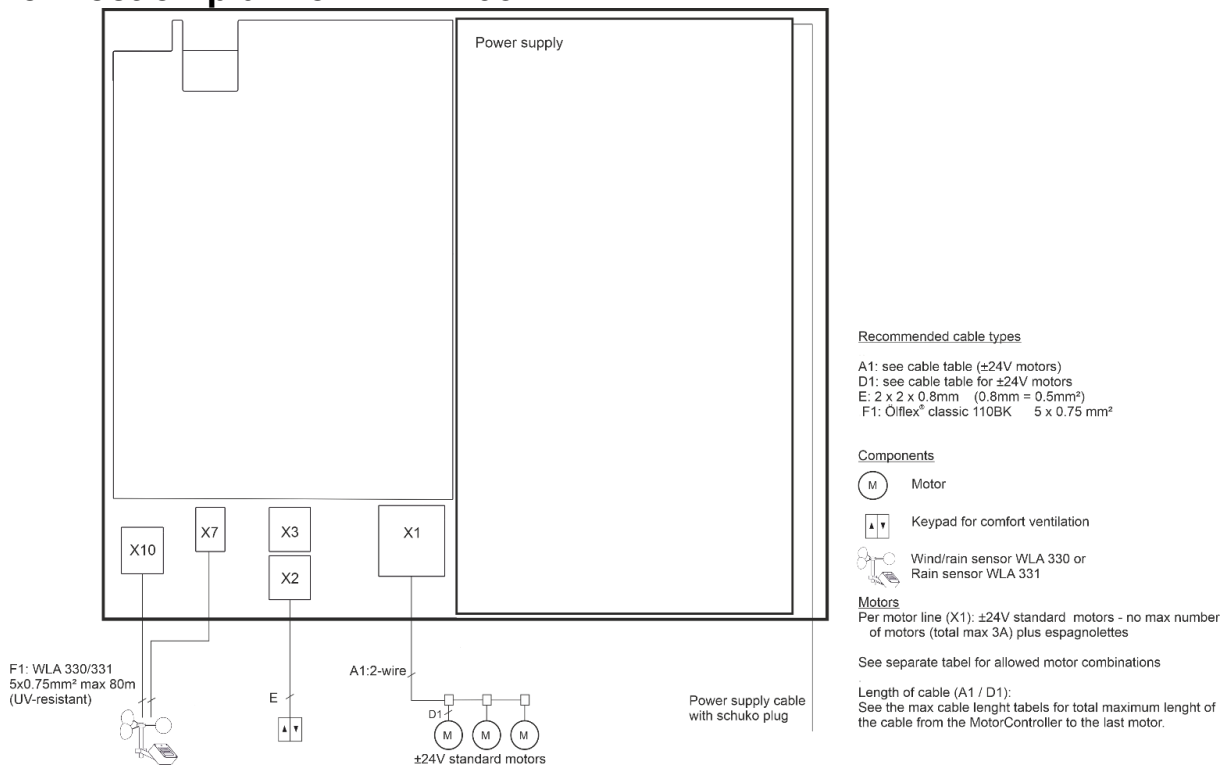

The above connection plan shows a WCC 103 A MotorController

## 9 Connection description

On the WCC 103 A the following can be connected:  $\pm 24V$  standard actuators, comfort keypad, thermostat and similar plus wind / rain sensor.

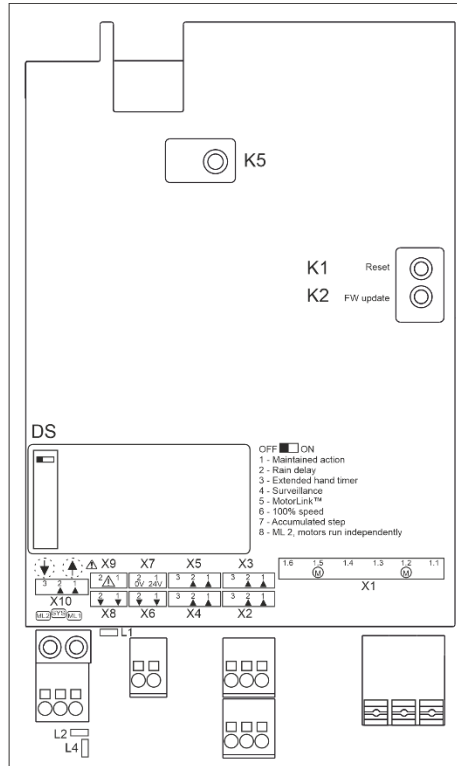

<b>X1</b>	1.1 24V / 0V	} Motor line #1	<b>X9</b>	9.1 Fault	} Output (only available on the 106BT version)
	1.2 0V / 24V			9.2 Fault	
	1.4 24V / 0V	} Motor line #2 (only available on the 106BT version)	<b>X10</b>	10.1 Common open	} Common / Weather station
	1.5 0V / 24V			10.2 Common close (Rain)	
				10.3 GND / 0V	
<b>X2</b>	2.1 Open	} Comfort keypad #1	<b>DS</b>	DIP switch 1	
	2.2 Close			} Close and open all windows	
	2.3 GND / 0V				
<b>X3</b>	3.1 Open	} Automatic control #1	<b>K1</b>	Reset	
	3.2 Close				
	3.3 GND / 0V				
<b>X4</b>	4.1 Open	} Comfort keypad #2 (only available on the 106BT version)	<b>K2</b>	Firmware update	
	4.2 Close				
	4.3 GND / 0V				
<b>X5</b>	5.1 Open	} Automatic control #2 (only available on the 106BT version)	<b>K5</b>	Pairing	
	5.2 Close				
	5.3 GND / 0V				
<b>X6</b>	6.1 Output #1	} Status (open) (only available on the 106BT version)	<b>L1</b>	LED 1 - Sum error	
	6.2 Output #1				
<b>X7</b>	7.1 24V	} AUX, power supply for external sensor	<b>L2</b>	LED 2 - System status	
	7.2 0V				
<b>X8</b>	8.1 Output #2	} Status (open) (only available on the 106BT version)	<b>L4</b>	LED 4 - Motorline #1 status	
	8.2 Output #2				

**X1** WCC 103 A contains one motor line to which only  $\pm 24V$  standard actuators can be connected.

### Data

- 1.1 24V / 0V
- 1.2
- 1.3 0V / 24V

The number of permitted actuators on the motor line depends on the actuator type. The total current consumption connected to the motor line incl. load on X7 (AUX) may not exceed 3A. In addition to the actuators, locking actuators of type WMB 8xx may also be connected. The locking actuators' power consumption is not included in the calculated 3A as the actuators and locking actuators do not run simultaneously.

All actuators on the same motor line run/are operated at the same time.  
All actuators on a motor line must be the same type.

Connection / cable diameter: flexible max 6 mm<sup>2</sup> / solid max 10 mm<sup>2</sup>.  
Cable length: see the chapter "Cable dimensioning".

**Standard ±24V actuators**

Example with max. 3A current consumption

- a) 3 pcs. WMX 826-1
- b) 2 sets of 3 pcs. WMX 504-3
- c) 1 pc. WMU 883-1
- d) 2 pcs. WMU 861-2

**Connecting variants to standard actuators on motor line 1**

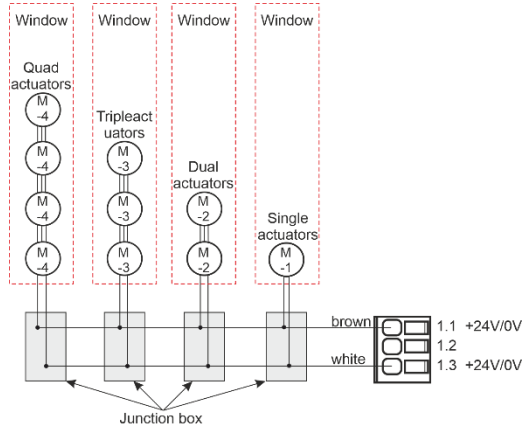

**X2**

Input for connection of comfort keypad

Data:

- 2.1 Open
- 2.2 Close
- 2.3 GND / 0V

With the factory-set values the input is:  
 "Active" if resistor is less than 5kΩ  
 "Inactive" if resistor is greater than 8kΩ.

Input has pull-up current of approx. 1mA (min. 0.9mA, max. 1.1mA) if input short-circuits.

Example: Comfort keypad connected to input X2

**Input circuit (simplified)**

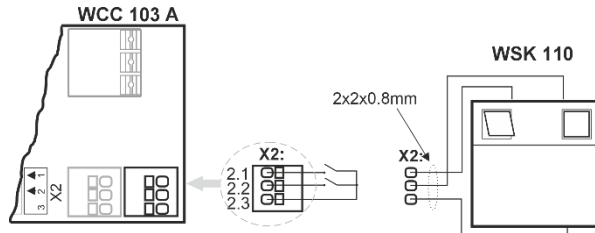
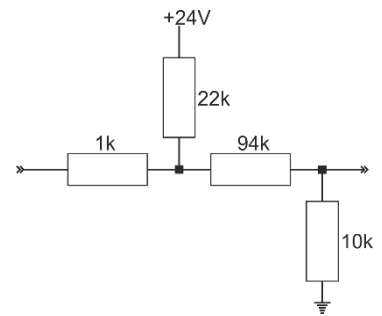

Long press (>500ms): open/close actuator, actuator runs to end stop  
 Short press: actuator stops running

**X3**

Input for automatic control.

Data:

- 3.1 Open
- 3.2 Close
- 3.3 GND / 0V

X3 must be controlled by a potential/volt free contact.

X3 has lower priority than X2.

X3 is blocked for 30 minutes after X2 has received a command (from production code 11BM03KW).

**X7**

AUX, power supply for weather station, for example. See "X10" for a description of connection of rain/wind sensors.

Data:

- 7.1 24V
- 7.2 0V

Maximum 500 mA

Main power must be switched off, before connecting any kind of external equipment to X7!  
 Connected consumption must be included in the controller's total load, which must not exceed 3A.

**X10** Connecting wind / rain sensors of type WLA 330 or WLA 331.  
Wind / rain sensor must be connected on both X10 and X7.

Data:

- 10.1 Common Open
- 10.2 Common Close (Rain)
- 10.3 GND / 0V

X10 has highest priority over X2 and X3.

With the factory-set values the input is:  
"Active" if resistor is less than 5kΩ  
"Inactive" if resistor is greater than 8kΩ.

Input has pull-up of approx. 1mA (min. 0.9mA, max. 1.1mA)

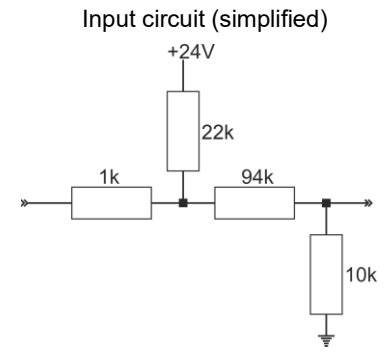

**Connecting wind/rain and rain sensor**

WLA 330 and WLA 331– the sensors settings are set on the sensor.

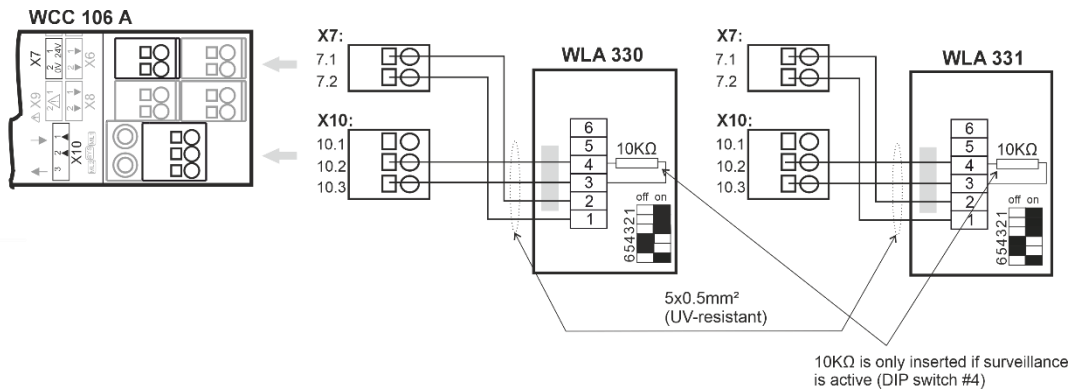

DIP switches 1-3 on WLA 330 must be set in relation to windspeed tolerances. See the guideline for WLA 330 for DIP switch settings.

**DS** DIP switch for configuration of holding on connected comfort keypad on X2.

ON = holding activated  
OFF = holding deactivated

Factory setting = OFF

↓ ↑ Close / Open all windows

**K1** Reset

**K2** FW update; to be used in line with firmware updates

**K5** Pairing, used when the MotorController is to be paired with the remote-control type WCA 100

**LED 1** Yellow LED that indicates error on the MotorController.  
If the diode is off, there is no error/failure.  
See chapter, "Status and troubleshooting via LED on the MotorController" for more information.

**LED 2** Green LED that shows status of MotorController.  
If diode lights constantly, there is no error/failure.  
If the diode blinks, see chapter, "Status and troubleshooting via LED on the MotorController" for more information.

**LED 4** Green LED that shows status of the motor line.  
The diode can light constantly or blink asynchronously.  
See chapter, "Status and troubleshooting via LED on the MotorController" for more information.

# 10 Control via remote control – WCA 100

The window actuators connected to the MotorController can be controlled (opening and closing) with a remote-control type WCA 100

The remote control has an operation range up to 50m outside and 10m inside. Physical barriers such as walls, cabinets etc. will reduce the operation range.



The remote control has 3 buttons, each with 3 keys (functions) – OPEN, STOP and CLOSE.

However, when paired with the WCC 103 A, it is only the top and bottom button which are working, meaning the middle button does not have any function.

Button and key functions on the remote control

<div style="display: flex; align-items: center; justify-content: center;"> <table border="1" style="margin-right: 20px;"> <tr><td>#1</td><td>#4</td><td>#7</td></tr> <tr><td>#2</td><td>#5</td><td>#8</td></tr> <tr><td>#3</td><td>#6</td><td>#9</td></tr> </table> <p>Button and key function overview</p> </div>	#1	#4	#7	#2	#5	#8	#3	#6	#9	<b>Key number</b>	▲ #1	■ #4	▼ #7
	#1	#4	#7										
	#2	#5	#8										
#3	#6	#9											
<b>Function</b>	Actuators connected to ML #1 open	Actuators connected to ML #1 stop	Actuators connected to ML #1 close										
<b>Key number</b>	▲ #2	■ #5	▼ #8										
<b>Function</b>	No function with WCC 103 A	No function with WCC 103 A	No function with WCC 103 A										
<b>Key number</b>	▲ #3	■ #6	▼ #9										
<b>Function</b>	All actuators connected to WCC 103 A open	All actuators connected to WCC 103 A stop	All actuators connected to WCC 103 A close										

ML = motor line

A short blink on the remote control's green LED indicates that the command from the remote control to the MotorController has been received by the MotorController.

A short blink on the remote control's red LED indicates that the command from the remote control to the MotorController has not been received by the MotorController.

## 10.1 Before use

The remote control is supplied with 2 x AAA batteries, which must be inserted before use.

Furthermore, the remote control and the MotorController must be paired with each other before the remote control can operate the actuators connected to the MotorController.

### 10.1.1 Pairing of remote control and MotorController

To avoid any disturbances the remote control must be held close to the MotorController during pairing. Only activate pairing mode on one MotorController at the time, otherwise, the remote control will pair with the MotorController with the strongest signal.

A remote control can only be paired with one MotorController.

#### MotorController

1. Activate pairing mode on MotorControlleren by pressing K5 (pairing button) on the MotorControlleren.

#### Remote control

The remote control differs between two different presses: a short and a long press.

The short press is used for normal/daily operation, meaning control of the window actuators. The long press is used for the pairing process.

Short press: the press lasts max. 3 sec.

Long press: the press lasts min. 3 sec.

1. Activate pairing mode on the remote control, by pressing simultaneously on key #3 and #9 – see above "Button and key function overview". The press must be a long press on both keys meaning min. 3 sec. When the remote control is in pairing mode it starts blinking first red and then green double blinks.
2. As the remote control only can be paired with one MotorController, the remote control automatically deletes any previously paired MotorControllers before it starts the pairing process with the desired MotorController.

3. The remote control starts a scanning process to identify the desired MotorController, which also must be the one closest to the remote control.  
On the remote control, the scanning is indicated by the green LED, which every second blinks two short blinks.
4. a) The LED on the remote-control blinks one long green blink. The pairing process was a success, the remote control and the MotorController is now paired.  
b) The LED on the remote-control blinks one long red blink. The pairing process failed.

The pairing process succeeded:

The MotorController and remote control are now ready for use. Carry out a test run, if this is the MotorController's first pairing, see section "Commissioning and test run".

The pairing process failed:

- Ensure the batteries are inserted correctly into the remote control.
- Ensure the MotorController has been connected to 230V and that pairing mode is activated.
- Ensure MotorController and remote control – during the pairing process – are close to each other and that there are no disturbances between them, such as walls, furniture etc.
- Replace the batteries in the remote control.
- Repeat the pairing process.
- Reset the *Bluetooth*<sup>®</sup> module in the MotorController
  - o Press K5 (the pairing button) until the LED blinks red (double blink)
  - o Release K5 (the pairing button) shortly
  - o Press K5 (the pairing button) again, until the LED blinks red-green (2 x red, 1 x green)
 The module has been reset and cleared from all previous pairings a new pairing must be carried out.

If the pairing process continues to fail, please contact your local WindowMaster office.

## 11 Control via app – Fresh Air Control

The windows can also be controlled via app. The MotorController must be version 02 or higher for the app to be used.

The app "Fresh Air Control" can be downloaded from Google Play or App Store.

The app can connect to several MotorControllers. WindowMaster recommends connecting max. 5 MotorControllers to a smartphone/tablet and max. 5 smartphones/ tablets to a MotorController.

The app is user friendly and intuitive and explains the pairing process in steps.

The pairing process failed:

- Ensure the phone's *Bluetooth*<sup>®</sup> is active.
- Ensure the MotorController has been connected to 230V and that pairing mode is activated.
- Ensure MotorController and phone – during the pairing process – are close to each other and there are no disturbances between them, such as walls, furniture etc.
- Ensure other active apps are not "blocking" any pairing notifications

### 1. If pairing continuous to fail

- Delete the device in the "Fresh Air Control" app by using the "Remove device" menu under settings.
- Delete the device in the phone's *Bluetooth*<sup>®</sup> list under "Paired Devices". The device will be listed as "WindowMaster Module 0102"
- Restart the MotorController by disconnecting the 230V power supply for one minute or until all LEDs are off
- Restart your phone or turn off *Bluetooth*<sup>®</sup> briefly

### 2. If pairing continues to fail

- Reset the *Bluetooth*<sup>®</sup> module in the MotorController
  - o Press K5 (the pairing button) until the LED blinks red (double blink)
  - o Release K5 (the pairing button) shortly
  - o Press K5 (the pairing button) again, until the LED blinks red-green (2 x red, 1 x green)

The module has been reset and cleared from all previous pairings a new pairing must be carried out. Note that any physical remote controls must be paired again.

If the pairing process continues to fail, please contact your local WindowMaster office.

## 12 Status and troubleshooting via LED on the MotorController

In the event of failure/error of the MotorController one or more diodes will light and/or blink.  
 On the WCC 103 A there are 3 diodes - 2 green and 1 yellow - that can indicate errors on the MotorController.

Irrespective which diode lights or blinks, the indicator is based on a 3.2 second sequence that is repeated continuously. Each sequence is defined by 32 x 0.1 second time segments.

If there are several errors on the MotorController simultaneously they are displayed by priority, i.e., error messages for the most critical failures are shown first and repeated until the failure is remedied. Then error number two is shown, which likewise is repeated until the error is remedied etc. The following overview shows the most frequently occurring errors, if an error other than those listed below is indicated, contact WindowMaster.

### Yellow diode – LED 1

If the yellow diode lights, this indicates an error on the MotorController.  
 Black = diode off



Error indicator on the yellow diode is a total errors indicator. Detailed information on the error type can be decoded on the green diode.

### Green diode – LED 2

If the green diode LED 2 (closest to X10) blinks, this indicates the error on the MotorController.  
 Black = diode off

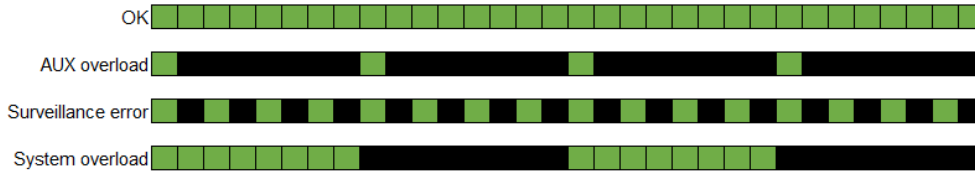

### Green diode – LED 4

The green diode LED 4 (furthest from X10) indicates status of or error on the motor line.  
 Black = diode off



## 13 Commissioning and test run

In the event of error messages, refer to chapter “Status and troubleshooting via LED”.

### 13.1 MotorController fully installed, without operating power

1. Check all mechanical and electrical components for damage.
2. Check all screw and plug connections for tightness and/or firm seating.
3. Check that all external components are installed; check polarity for the ±24V actuators

### 13.2 With network power

Adhere to the relevant regulations!  
 Connect the mains cables and reapply the mains voltage.

### 13.3 Remote control and comfort keypad

Look closely at the actuators as they open and close - there must not be any obstacles in any position, and the actuator connection wires must not be overstrained with pulling or pinching.  
 Test the remote control and every single comfort keypad if installed.

## 13.4 Wind/rain sensor

- a. Open the actuators with the comfort keypads.
- b. Dampen the rain sensor, the actuators close completely.
- c. While the actuators are running, press Open button on the comfort keypad. The actuators must neither open nor stop.

If commissioning proceeds correctly, the lid of the MotorController may be fitted.

If commissioning does not proceed correctly, i.e., there is an error in one of the test points, refer to chapter "Connection description" If necessary, re-test the cable routing in accordance with chapter "Connection plan for WCC 103 A".

## 14 Maintenance

Control and maintenance should only be done by the manufacturer or an authorized partner.

Remove all soiling from the MotorController. Check fastening and clamping screws for firm seating.

Carry out a test run of the entire system (see chapter 19 'Commissioning and test run).

Only have defective units repaired in our factory. Only install original spare parts.

The expected minimum lifetime for the MotorController is 10 years.

### 14.1 Maintenance agreement

WindowMaster offers a maintenance agreement for MotorController. Contact our service department for further information:

Tel. +44 1536 614 070 or [info.uk@windowmaster.com](mailto:info.uk@windowmaster.com)

## 15 Components declaration

The MotorController has been produced and tested in compliance with European guidelines.

The "Declaration of Conformity" is supplied with the MotorController as a separate document.