

## WCC 310 / 320 STANDARD UL UL MotorController



Natural  
ventilation



Rated voltage



MotorLink®



KNX product



UL certification  
– Controls

### Application

- for daily comfort ventilation
- to be used with  $\pm 24V$  standard window actuators and window actuators with MotorLink®
- 4 or 8 motor lines
- 10A or 20A
- With or without KNX

MotorController for the control of  $\pm 24V$  DC standard actuators and actuators with MotorLink® for daily comfort ventilation. It can also control espagnolette/locking actuators.

The MotorController is used for control of 4 or 8 individual motor lines. The number of actuators which can be connected on each motor line depends on the type of actuator – see the table “Max numbers of actuators per motor line and MotorController” for type and number.

### Versions

The MotorController is supplied in 4 variants:

With 10A:

- WCC 310 S 0410 U1: 10A, 4 motor lines, 10 inputs
- WCC 310 S 0410 KNX U1: 10A, 4 motor lines, 10 KNX-inputs

With 20A:

- WCC 320 S 0810 U1: 20A, 8 motor lines, 10 inputs
- WCC 320 S 0810 KNX U1: 20A, 8 motor lines, 10 KNX-inputs

In the MotorController each motor line can have a max load of 4A. The total max current consumption of all motor lines must not exceed 10A / 20A.

The MotorController is also supplied as a PLUS version where the configuration is done on the built-in touchscreen – please see the separate product sheet for further information.

### Description

The MotorController controls (opens/closes) the window actuators based on the signals from the connected components e.g. keypads, room sensor, weather sensor and BUS commands.

We recommend keypads are used in conjunction with ventilation automation to allow local manual user override.

### Communication

The communication between the MotorController and each window actuator is done via a 2 or 3 wire cable this depends, if the actuator has MotorLink® or not.

#### Actuators without MotorLink®

The communication is controlled via a 2 wire cable. The positioning of the windows is based on time control with a limited precision.

#### Actuators with MotorLink®

The communication is controlled digitally via MotorLink® in a 3-core (power and communication wire).

The position of the window is controlled with millimetre accuracy. This is done via the position feedback from the actuators to the MotorController. Via this communication the system continuously registers the extent of the window opening.

The MotorController immediately reports if a malfunction occurs on one of the motor lines.

## Actuator speeds

This MotorController gives the possibility of up to three window actuator speeds depending on the type of actuator connected:

- $\pm 24V$  DC standard actuator: 1 speed (type B)
- MotorLink® actuator: 1 speed (type B)
- MotorLink® actuator and bus communication, KNX version: 3 speeds (type A / B / C)

### The different speeds

A: Slow and almost soundless chain drive when operated automatically

B: Faster and audible when manually operated by comfort ventilation

C: 100% chain drive when operated by security functions

## Common input

The actuators can be controlled via four common inputs. All switch contacts must be potential free.

When connecting sensors the auxiliary power from the built-in 24V DC 0.23A power supply can be used.

### Option 1

Common CLOSE ALL/safety (rain) function

Actuator speed: B.

### Option 2

Self-hold function on all actuator groups.

Switch closed = self-hold.

### Option 3

Common "OPEN" function for all actuator groups.

No self-hold.

Actuator speed: B.

### Option 4

Common "CLOSE" function for all actuator groups.

No self-hold.

Actuator speed: B.

## MotorController with KNX

The MotorController is integrated into KNX projects using the relevant application. In the application there are a number of communication objects and parameters, which help ensure a flexible integration with other KNX products and control units.

For further information on available objects see "KNX Application Program Description" on our web site [www.windowmaster.com](http://www.windowmaster.com).

### Specifications

- 4 motor lines (comfort ventilation groups) up to 10A or 8 motor lines (comfort ventilation groups) up to 20A
- max. 4A/motor line
- supplied with or without KNX
- one comfort input "Close all"
- max. output voltage 27.6VDC @120VAC
- simple and fast installation

Actuator and power supply cables are quickly and easily connected to the MotorController. The cable access can be made from the top or from underneath the MotorController, which can be mounted vertically or horizontally on the wall.

**Example 1: WCC 310 S 0410 with wind / rain sensor**

In each room actuators with MotorLink® have been connected as well as individual keypads for individual operation of the windows.

A wind/rain sensor is mounted on the roof.

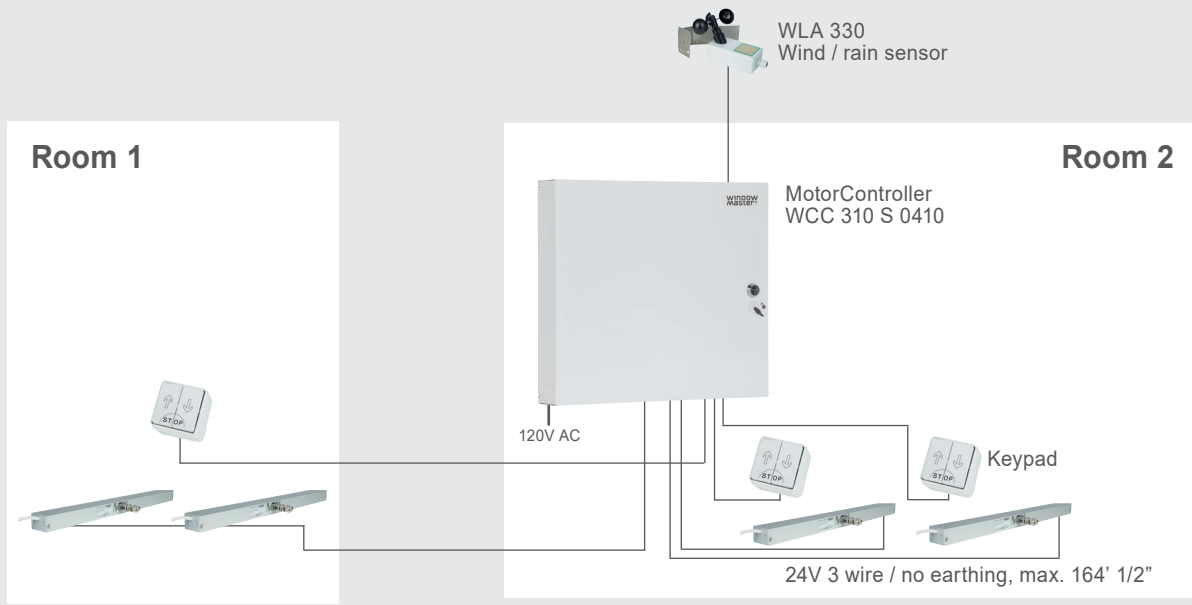

Technical specifications							
Output current	WCC 310: 10A / WCC 320: 20A						
Motor lines	4 or 8 motor lines A line can be either a $\pm 24V$ standard motor line or a MotorLink <sup>®</sup> motor line.						
Primary voltage	120V AC, 60Hz (85-264V AC, 47-63Hz)						
Actuator secondary voltage	<table border="1"> <tr> <td>Nominal voltage</td> <td>24V DC (<math>\pm 15\%</math>)</td> </tr> <tr> <td>Open circuit voltage at 120V AC (no load)</td> <td>27.6V DC @ 20°C</td> </tr> <tr> <td>Ripple at max load</td> <td>max 6% (3,5Vpp)</td> </tr> </table>	Nominal voltage	24V DC ( $\pm 15\%$ )	Open circuit voltage at 120V AC (no load)	27.6V DC @ 20°C	Ripple at max load	max 6% (3,5Vpp)
Nominal voltage	24V DC ( $\pm 15\%$ )						
Open circuit voltage at 120V AC (no load)	27.6V DC @ 20°C						
Ripple at max load	max 6% (3,5Vpp)						
Power consumption	<p>WCC 310: min 1.1W<sup>1</sup>, typ. 3W<sup>2</sup>. At max load 305W  WCC 320: min 1.1W<sup>1</sup>, typ. 3.5W<sup>3</sup>. At max load 605W</p> <p>1) min.: 1 actuator  2) typ.: 16 MotorLink<sup>®</sup> actuators + rain sensor  3) typ.: 32 MotorLink<sup>®</sup> actuators + rain sensor</p>						
Inrush current on primary site	<p>70A &lt; 5ms  Max 3 x WCC 310/320 per 10 A supply group.  Circuit breaker "C" characteristic.</p>						
Leakage current	max 1.2mA @ 240VAC						
AUX	24V DC, 230 mA						
Operating conditions	+23°F – +113°F, for indoor installation, the controller may not be covered						
Switch-on duration	ED 40% (4 min. per 10 min.)						
Connection cable	<p><b>Actuators</b>  Flexible max 10AWG / solid max 8AWG, max. 2V power loss.  MotorLink<sup>®</sup> actuator however cables max. 164' 1/2"  Min. 22AWG, 300V, 176°F  Listed / Recognized to UL 13</p> <p><b>Other components</b>  Min 24AWG / max 16 AWG  Listed / Recognized to UL 13</p> <p><b>Mains</b>  Mains must be done per relevant Electrical Code.  For permanent connection (rigid or flexible 1/2" conduit or equivalent) use the supplied 1/2" adaptor in the Knockout. Use 10, 12, or 14AWG conductors (same size).  Listed / Recognized to UL 13</p>						
Size	1' 2" x 1' 5/8" x 3" (WxHxD)						
Material	Lacquered metal housing for surface mounting						
Colour	White (RAL 9010)						
Weight	WCC 310: 8.8lbs / WCC 320: 10.6lbs						
IP rating	IP20						
Certification	UL 325 and CSA C22.2 no 247-14 approved						
Delivery includes	MotorController						
Spare parts	See the spare part list on our website windowmaster.com under "Products"						
Note	We reserve the right to make technical changes						

## Max numbers of actuators per motor line and MotorController

The table shows the maximum number of actuators, which can be connected per motor line and MotorController depending on the type of actuator ( $\pm 24V$  standard or MotorLink<sup>®</sup> actuator) and MotorController.

**Notice:** For actuators with MotorLink<sup>®</sup> always max. 4 actuators per motor line. The total power consumption of all the connected actuators must not exceed 10A for WCC 310 and 20A for WCC 320.

WCC 310 / WCC 320 STANDARD UL – maximum numbers of actuators						
Actuator type	Per motor line		Per WCC 310 S 0410		Per WCC 320 S 0810	
	$\pm 24V$	MotorLink <sup>®</sup>	$\pm 24V$	MotorLink <sup>®</sup>	$\pm 24V$	MotorLink <sup>®</sup>
WMU 831 / 836 / 851-1	4	4	10	10	20	20
WMU 831 / 836 / 851-2	4	2	10	8	20	16
WMU 831 / 836 / 851-3	3	3	9	9	18	18
WMU 831 / 836 / 851-4	4	4	8	8	20	20
WMU 861-1	4	4	8	8	16	16
WMU 861-2	4	2	8	8	16	16
WMU 861-3	3	3	6	6	15	15
WMU 861-4	4	4	8	8	16	16
WMU 842 / 852 / 862 / 882-1	2	2	4	4	8	8
WMU 842 / 852 / 862 / 882-2	2	2	4	4	8	8
WMU 863 / 883-1	1	1	3	3	6	6
WMU 864 / 884-1	1	1	2	2	5	5
WMX 503 / 504 / 523 / 526-1	8	4	20	16	40	32
WMX 503 / 504 / 523 / 526-2	8	2	20	8	40	16
WMX 503 / 504 / 523 / 526-3	6	3	18	12	39	24
WMX 503 / 504 / 523 / 526-4	8	4	20	16	40	32
WMX 803 / 804 / 813 / 814 / 823 / 826-1	4	4	10	10	20	20
WMX 803 / 804 / 813 / 814 / 823 / 826-2	4	2	10	8	20	16
WMX 803 / 804 / 813 / 814 / 823 / 826-3	3	3	9	9	18	18
WMX 803 / 804 / 813 / 814 / 823 / 826-4	4	4	8	8	20	20
WMB 801/802*	Actuators with a total of max. of 4A can be connected to the locking actuator					
WMB 811/812 **	4	2	10	8	20	16

\* Do not exceed the total power consumption of the motor line

\*\* When having two locking actuators on one motor line use: 1 x WMB 811 and 1 x WMB 812

# WCC 310 / 320 STANDARD UL

## UL MotorController

### MotorLink® combinations: Actuator variants on one MotorLink® motor line

- When connecting window actuators one should pay attention to:
  - The max current load of the MotorControllers is 4A per motor line. The simultaneously max current consumption of all motor lines must not exceed 10A on a WCC 310 and 20A on a WCC 320. Actuators with MotorLink®: max 4 actuators per motor line.
  - The cable length and cross section: max voltage drop 2V in the cable, however max distance between the MotorController and the window actuators is 164' 1/2''
- Aside from window actuators; espagnolette actuators type WMB 811 / 812 (one single or two double actuators) can be connected to the window. When connecting an espagnolette actuator each window must have its own motor line.

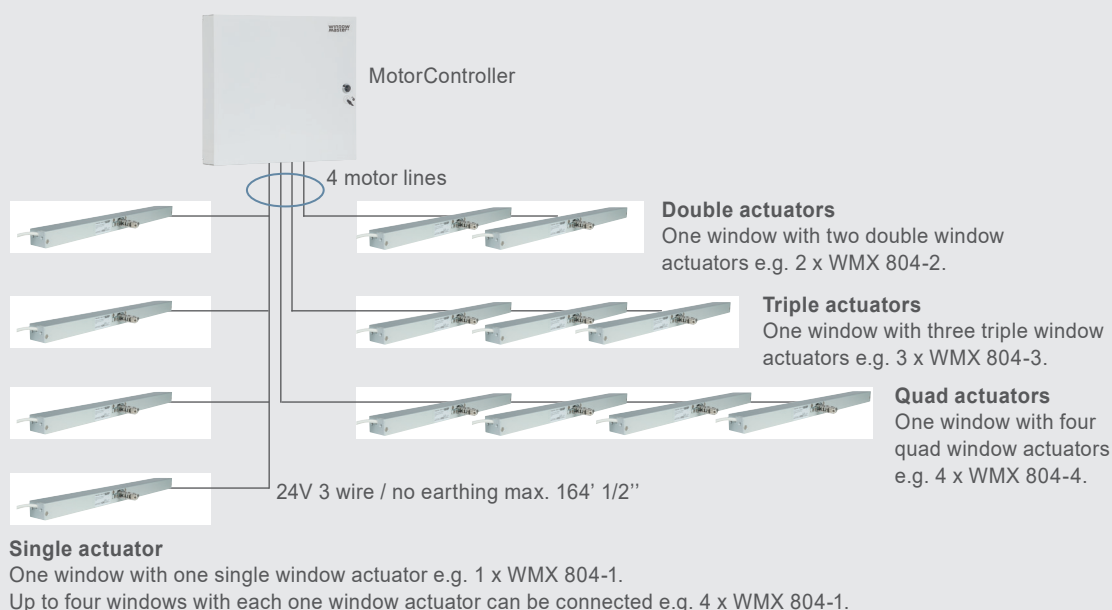

Variants	Number of motor lines	Number of inputs	Item no.
MotorController 10A	4 motor lines each 3.15A (in total max. 10A)	10 input	WCC 310 S 0410 U1
MotorController 10A	4 motor lines each 3.15A (in total max. 10A)	10 KNX input	WCC 310 S 0410 KNX U1
MotorController 20A	8 motor lines each 3.15A (in total max. 20A)	10 input	WCC 320 S 0810 U1
MotorController 20A	8 motor lines each 3.15A (in total max. 20A)	10 KNX input	WCC 320 S 0810 KNX U1

Accessories	Item no.
Rain and wind sensor	WLA 330
Rain sensor	WLA 331
Rain and wind sensor	WLA 340
USB stick for log-data, back-up and firmware updates	WCA 304
Comfort keypad for 1 window or 1 window group	WSK 110 0A0B
Comfort keypad for 2 windows or 2 window groups	WSK 120 0A0B 0A0B

All dimensions are originally in metric units and converted into imperial units.  
For exact measurements please refer to documentation with metric values.