

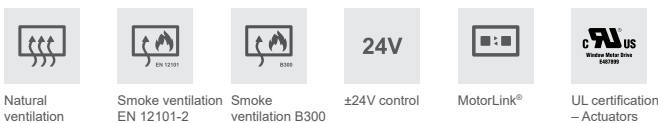

WMU 836 Chain actuator 300N



Natural
ventilation

Smoke ventilation
EN 12101-2

Smoke
ventilation B300

±24V control

MotorLink®

UL certification
- Actuators

2.11

Description

- designed for surface mounting
- for comfort ventilation
- for smoke ventilation DIN 18232-3
- for smoke ventilation EN 12101-2: The EN-actuators are approved according to EN 12101-2 with selected profiles
- to be used with all window types
- to be used together with $\pm 24V$ control units or control units with MotorLink®
- can be used together with espagnolette WMB
- synchronization of up to four window actuators – no need for an external synchronization module
- genuine position feedback and three speeds when using control unit with MotorLink®
- soft close function
- built-in electronic load switch-off/end stop
- electronic actuator with micro controller
- the actuator has an integrated reverse function to ensure a prolonged life span of the window gaskets
- easy mounting

Actuator variants

The actuator is available in four different versions: single actuator (-1), double actuator (-2), triple actuator (-3) and quad actuator (-4).

The synchro actuators (-2, -3 and -4) are equipped with a synchronization function, in which the actuators communicate directly with each other, which ensures the actuators operate at exactly the same speed and position.

On large windows up to four actuators can be mounted on the

same window – with no need for an external synchronization module.

Opening speed

The number of window actuator running speeds (up to three) depends on the type of control unit to which the window actuator is connected.

One speed:

Actuators connected to ± 24 VDC control units (e.g. WUC) can be run with one speed – see the following page for opening speed.

Three speeds:

Actuators connected to control units with MotorLink® (e.g. WCC) can be run with three different speeds:

- automatically control speed – actuators run slowly and almost soundlessly.
- manual control speed – actuators run faster and more audibly.
- H&S and safety control speed – actuators run fastest. H&S control always has highest priority.

Technical specifications	
Pressure force	See variant table and stroke / force diagram
Traction force	300N
Locking force	3000N
Chain stroke	400, 600, 800 and 1000mm
Opening speed	4,5 - 14 mm/s
Sound pressure level	≤30 dBA (operational speed: 4,5 mm/s), ≤45 dBA (operational speed: 13 mm/s)
Window types	Tophung, bottomhung, pivot and turning window - vent size should be confirmed with the window supplier and WindowMaster
Nominal voltage	24 VDC (max. 10% ripple)
Voltage	20 - 36 VDC
Open circuit voltage	Max. 36 VDC
Current consumption	Max. 1,0A
Consumption of power	Max. 24W
Operating conditions	-5°C - +74°C, max. 90% relative humidity (not condensing)
Switch-on-duration	ED 40% (max. 4min. per 10min)
Material	Anodised aluminium housing with stainless steel chain WMU 836: with 5m grey silicone cable 3-cores 0.75m ² WMU 836 UL: with 5m UL approved cable, grey, 3-cores 0.82 mm ²
Colour	Anodized aluminium. RAL colours available at an additional price
Size	34 x 47mm (H x D), length (L) depending on chain stroke – see table
Weight	400mm: 2.2kg, 600mm: 2.6kg, 800mm: 3.0kg, 1000mm: 3.4kg
IP rating	IP32
EN approval	Approved according to EN 12101-2 with selected profiles – please contact WindowMaster for further information B300 tested according to EN 12101-2
Certification	Actuators with "UL" in the article no. are UL certified accordingly to UL 325 and CAN/CSA-22.2 No. 247-14. Primarily used in USA and Canada.
Life span	Tested with 10,000 opening and closing movements
Delivery includes	5m cable
To be ordered separately	Actuator bracket and chain bracket
Note	We reserve the right to make technical changes

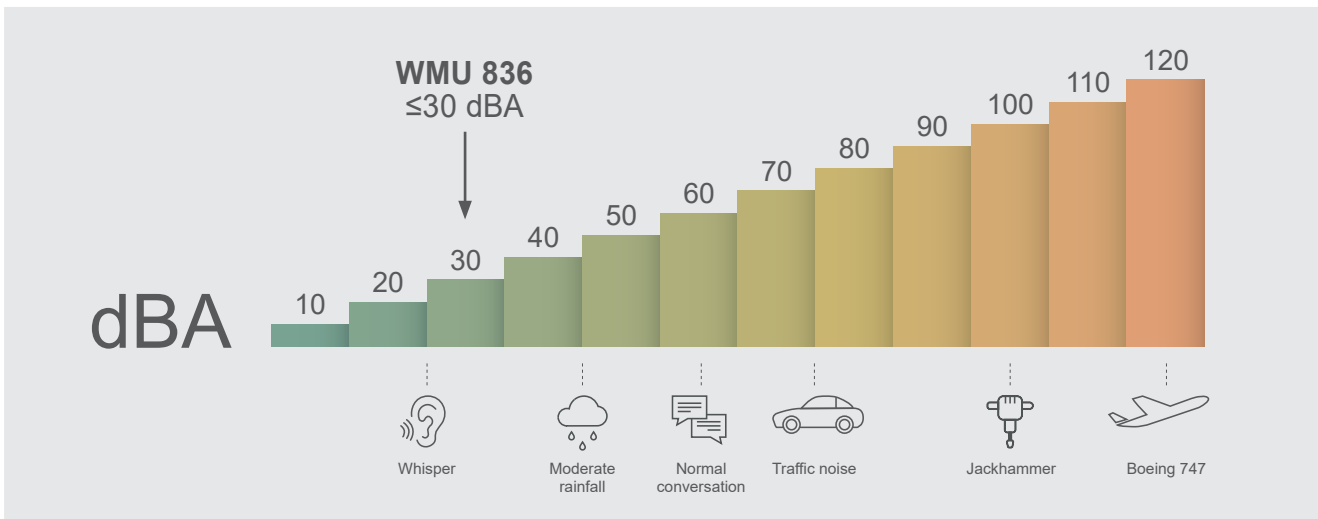

The sound pressure level was measured externally by The Danish Technological Institute. The measurements have been carried out in a large regular room size 7 x 14 x 2.4 m (W x L x H) with the ceiling covered with a standard sound absorbent material. The A-weighted sound pressure levels have been measured at a distance of 1 meter away from the surface of the actuators and at the height of 1.6 meters from the floor. The actuators were not installed on any window profile nor added any load. The full opening and full closing sound of the actuators have been measured and the result represents the average of the measurements.

Description of product code composition				
WMU 836	-n	xx	xxxx	0103
			Product version: 3	
			Stroke: 0400 = 400mm, 0600 = 600mm, 0800 = 800mm, 1000* = 1000mm	
			Certification EN: For actuator approved according to EN 12101-2 the item number must contain EN. Notice: Are supplied with strokes of 400mm, 600mm and 800mm. UL: For UL certified actuator the item number must contain UL.	
Actuator variant: 1 = single, 2 = double, 3 = triple, 4 = quad				
* 1000mm is not supplied as EN-12101-2 approved actuator				
Example of product code				
WMU 836-2 EN 0600 0103 WMU 836 actuator, double synchronisation, EN 12101-2 approved, 600mm chain stroke, product version 3				

Items	Chain stroke [mm]	Compressive force [N] * (only bottom hung window)	Length (L) [mm] (incl. screws = 18mm)	Item no. Europe	Item no. USA/Canada
Single actuator	400	300	568	WMU 836-1 0400	WMU 836-1 UL 0400
	600	170	668	WMU 836-1 0600	WMU 836-1 UL 0600
	800	0*	768	WMU 836-1 0800	WMU 836-1 UL 0800
	1000	0*	868	WMU 836-1 1000	WMU 836-1 UL 1000
Double actuator	400	300	568	WMU 836-2 0400	WMU 836-2 UL 0400
	600	170	668	WMU 836-2 0600	WMU 836-2 UL 0600
	800	0*	768	WMU 836-2 0800	WMU 836-2 UL 0800
	1000	0*	868	WMU 836-2 1000	WMU 836-2 UL 1000
Triple actuator	400	300	568	WMU 836-3 0400	WMU 836-3 UL 0400
	600	170	668	WMU 836-3 0600	WMU 836-3 UL 0600
	800	0*	768	WMU 836-3 0800	WMU 836-3 UL 0800
	1000	0*	868	WMU 836-3 1000	WMU 836-3 UL 1000
Quad actuator	400 mm	300	568 mm	WMU 836-4 0400	WMU 836-4 UL 0400
	600 mm	170	668 mm	WMU 836-4 0600	WMU 836-4 UL 0600
	800 mm	0*	768 mm	WMU 836-4 0800	WMU 836-4 UL 0800
	1000 mm	0*	868 mm	WMU 836-4 1000	WMU 836-4 UL 1000

Actuators approved according to EN 12101-2 – contact WindowMaster

Accessories	Item no.
Bracket set for frame mounting	WAZ 101
Bracket set for sash mounting	WAZ 102
Chain bracket for WMU 836 / 936	WAB 811
Actuator bracket for WMU 836 / 936	WAB 812
Actuator bracket for WMU 836	WAB 824
Z-Bracket for inward opening windows	WAB 825
Actuator bracket for WMU 836 / 936 / 866	WAB 836A
Actuator bracket for WMU 836 / 936 / 866	WAB 836B
Chain bracket for WMU 836 / 936	WAB 836E
Actuator bracket for WMU 836 – sash mounting	WAB 836P
Shortening electronically of chain	WKK
See separate product sheets for further information.	

Installation suggestion 1 - Outward opening, frame mounting

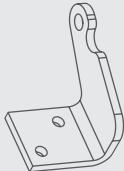

WAB 836B

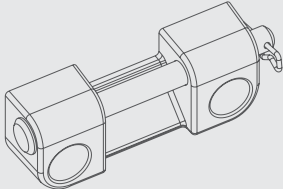

WAB 836E

Installation suggestion 2 - Inward opening, frame mounting

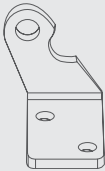

WAB 824

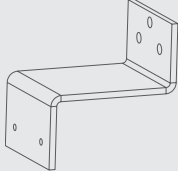

WAB 825

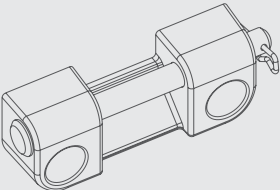

WAB 836E

Installation suggestion 3 - Inward opening, sash mounting

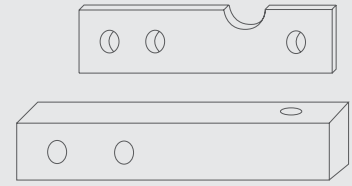
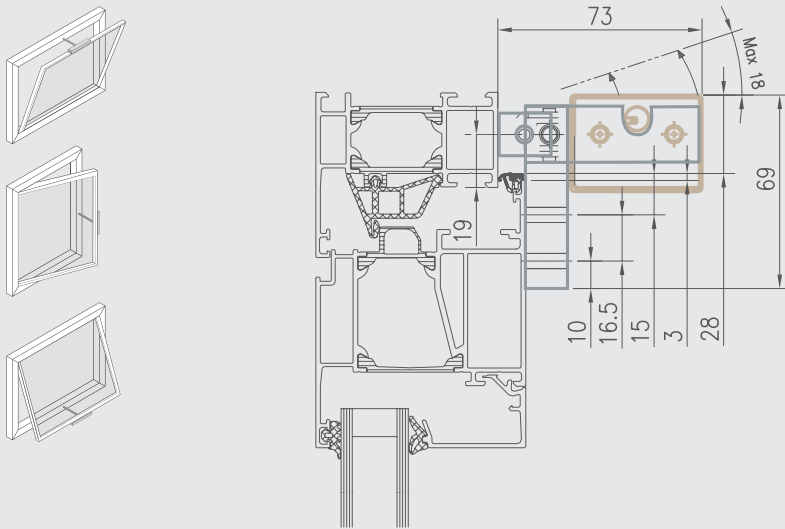

WAB 812

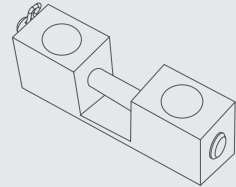

WAB 811

Installation suggestion 4 (frame mounting)

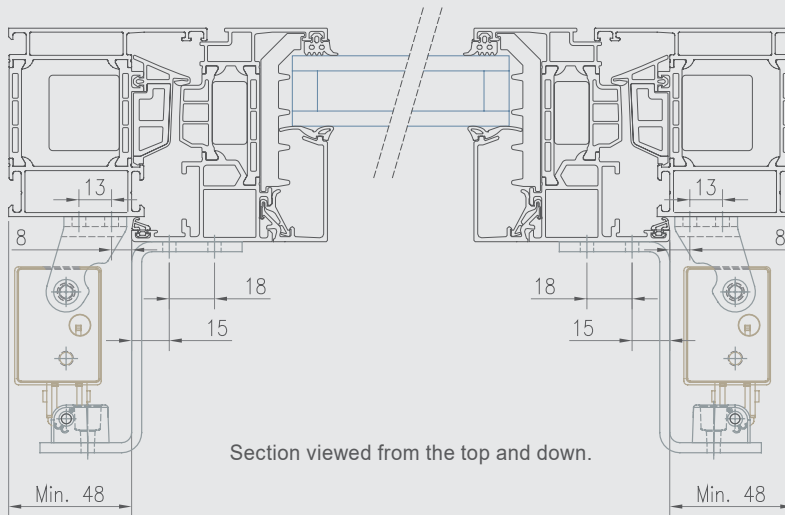

Bracket set WAZ 101 consists of:



2 x WAB 824

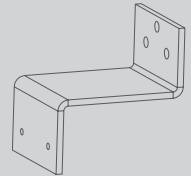

2 x WAB 825

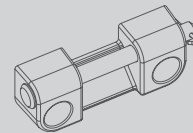

2 x WAB 836E

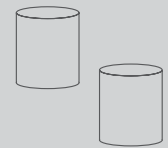

2 x brass tubes

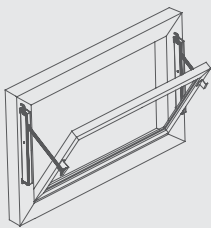

Solution:

2 x actuator WMU 836-2 xxxx
1 x bracket set WAZ 101.

The actuator cable exit has to turn upward.

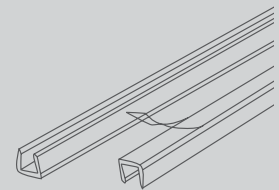

2 x cable channels 1m

WMU 836

Chain actuator 300N

Installation suggestion 5 (sash mounting)

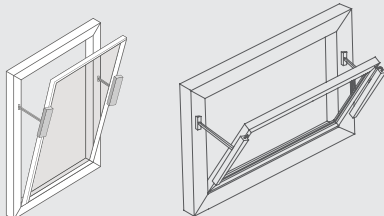
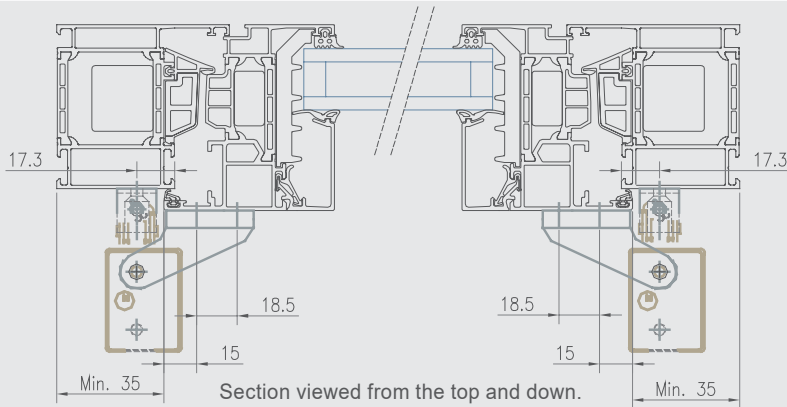

Solution:
 2 x actuators WMU 836-2 xxxx
 1 x bracket set WAZ 102.

The actuator cable exit has to turn upward.

Bracket set WAZ 102 consists of:

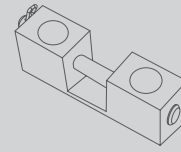

2 x WAB 811

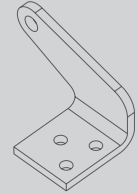

2 x WAB 836P

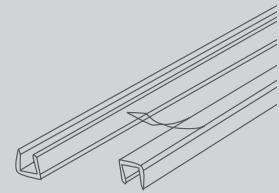

2 x cable channels på 1m

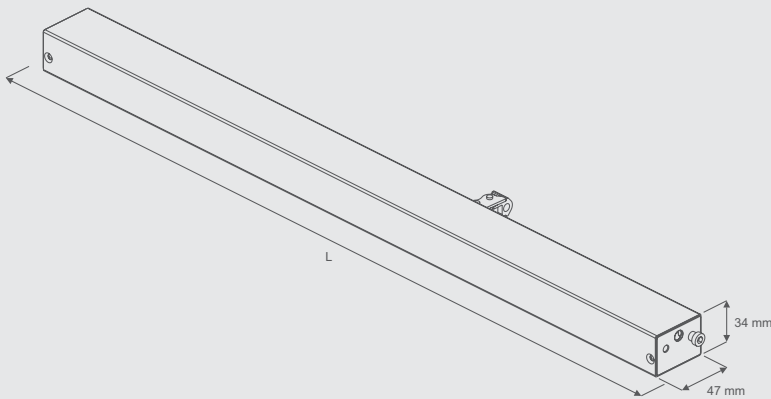

L = Length (incl. screws) – see table of items

— Pressure force — Traction force

