



## WMX 503 / 503 UL / 803 / 803 UL Chain actuator



Natural  
ventilation



±24V control



MotorLink®



UL certification  
– Actuators

1.34

### Description

- optimized design for concealed installation in window profiles
- for comfort ventilation
- to be used with all window types
- to be used together with ±24V control units or control units with MotorLink®
- can be used together with espagnolette WMB
- external safety edge can be connected directly to the actuator (actuator version 'E')
- available with and without UL certification:
  - Europe: order without UL certification
  - USA / Canada: order with UL certification (version UL)
- synchronization of up to four window actuators – no need for an external synchronization module
- genuine position feedback and three speeds when using control unit with MotorLink®
- soft close
- built-in electronic load switch-off/end stop
- electronic actuator with micro controller
- the actuator has an integrated reverse function to ensure a prolonged life span of the window gaskets
- easy mounting

### Actuator variants

The actuator is available in four different versions: single actuator (-1), double actuator (-2), triple actuator (-3) and quad actuator (-4).

The synchro actuators (-2, -3 and -4) are equipped with a synchronization function, in which the actuators communicate directly with each other, which ensures the actuators operate at exactly the same speed and position.

On large windows up to four actuators can be mounted on the same window – with no need for an external synchronization module.

### Pressure safety function

The risk of entrapment is reduced as the actuators are programmed to reverse if they encounter obstacles when closing. The set points determining when the actuators are to reverse are individually adjustable.



Version S



Version E

### Opening speeds

One speed:

Actuators connected to  $\pm 24$  VDC control units (e.g. WUC) can be run with one speed – see the following page for opening speed.

Three speeds:

Actuators connected to control units with MotorLink® (e.g. WCC) can be run with three different speeds:

- automatically control speed – actuators run slowly and almost soundlessly.
- manual control speed – actuators run faster and more audibly.
- H&S and safety control speed – actuators run fastest. H&S control always has highest priority.

### Technical specifications

|   |   |
|---|---|
| <b>Permitted constant pressure load</b>                             | 45N by 10,000 opening and closing movements (up to 150N for special version with shorter chain lengths)   |
| <b>Permitted constant tractive load</b>                             | WMX 503 / 503 UL: 150N by 10,000 opening and closing movements<br>WMX 803 / 803 UL: 200N by 10,000 opening and closing movements  |
| <b>Locking force</b>  | 3000N   |
| <b>Permitted short pressure load when chain has run to end stop</b> | 100N  |
| <b>Short pressure capacity on motor</b>                             | Max. 150N (e.g. at the beginning of opening: sticky gasket, ice, wind speed)  |
| <b>Chain opening</b>  | 1 15/16" – 9 13/16" increments of 25/64", maximum opening depends on the window construction  |
| <b>Opening speed</b>  | 0.276 in/s (programmable 0.118 in/s up to 0.374 in/s)   |
| <b>Sound pressure level</b>   | ≤33 dBA (operational speed: 0.118 in/s), ≤43 dBA (operational speed: 0.374 in/s)  |
| <b>Window types</b>   | Window types and sizes must be agreed with the window supplier and WindowMaster   |
| <b>Window width</b>   | Min. 1' 3/8", maximum width depends on the window construction and the number of window actuators   |
| <b>Window height</b>  | Min. 1' 3 3/4", maximum height depends on the window construction and the number of window actuators  |
| <b>Nominal voltage</b>  | 24 VDC (max. 10% ripple)  |
| <b>Voltage</b>  | 20 - 36V DC   |
| <b>Max. open-circuit voltage</b>                                    | Max. 36V DC   |
| <b>Current consumption</b>  | WMX 503 / 503 UL: max. 0.5A<br>WMX 803 / 803 UL: max. 1A  |
| <b>Operating condition</b>  | +23°F – +113°F, max. 90% relative humidity (not condensing)   |
| <b>Switch-on-duration</b>   | ED 40% (max. 4 min. per 10 min)   |
| <b>Material</b>   | Lacquered zinc housing with 3/8" zinc chromate passivated steel chain and a 3' 15/16" cable with fast-in/fast-on connectors for connection to the extension cable WLL   |
| <b>Colour</b>   | Grey (RAL 9006)   |
| <b>Size</b>   | 1' 1 7/16" x 1 1/8" x 1 5/8" (L x H x W)  |
| <b>Weight</b>   | 2.2 lbs   |
| <b>IP rating</b>  | IP20 - when surface mounted / IP32 - when concealed   |
| <b>Certification</b>  | Actuators with "U" in the article no. are UL certified accordingly to UL 325 and CAN/CSA-22.2 No. 247-14 and is supplied with UL approved cables UL STYLE 2464  |
| <b>SHE test</b>   | WMX 503 / 503 UL / 803 UL: not SHE tested<br>WMX 803*: tested in accordance with DIN 18232-3, section 3.6 (30 minutes at 572°F)<br>*The construction of the actuator is identical with WMX 802, which has passed the SHE test |
| <b>Life span</b>  | Tested with 10,000 opening and closing movements  |
| <b>Delivery includes</b>  | Actuator with 3 15/16" cable with fast-in/fast-on connector for WLL cable   |
| <b>To be ordered separately</b>                                     | WLL extension cable   |
| <b>Note</b>   | We reserve the right to make technical changes  |

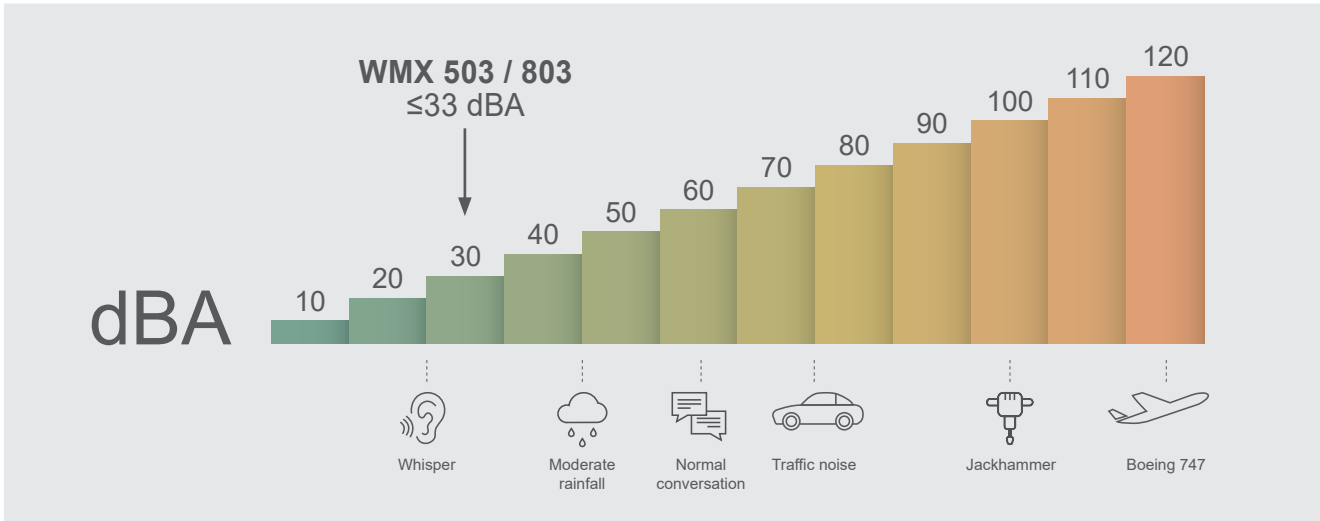

The sound pressure level was measured externally by The Danish Technological Institute. The measurements have been carried out in a large regular room size 7 x 14 x 2.4 m (W x L x H) with the ceiling covered with a standard sound absorbent material. The A-weighted sound pressure levels have been measured at a distance of 1 meter away from the surface of the actuators and at the height of 1.6 meters from the floor. The actuators were not installed on any window profile nor added any load. The full opening and full closing sound of the actuators have been measured and the result represents the average of the measurements.

| Product code composition <i>(actuator supplied in sealed plastic packaging)</i> |    |   |     |   |   |   |
|---|----|---|-----|---|---|---|
| WMX 503<br>WMX 803  | -n | G   | xxx | z | v | 3   |
|   |    |   |     |   |   | Product version: 3  |
|   |    |   |     |   |   | Certification: 0 = CE, U = CE + UL  |
|   |    |   |     |   |   | Actuator hardware version: S = standard, E = with connection for pressure safety (E: not UL actuator) |
|   |    |   |     |   |   | Chain opening: 1 15/16" – 9 13/16", in increments of 25/64" (050 = 25/64")                            |
|   |    |   |     |   |   | Colour: G = grey  |
| Actuator variant: 1= single, 2 = double, 3 = triple, 4 = quad                   |    |   |     |   |   |   |
| Explanation of product code structure:  |    |   |     |   |   |   |
| WMX 503-2G070E 03   |    | WMX 503 actuator, double synchronisation, grey, 2' 3/4" chain opening, with connection for pressure safety, with CE certification, product version 3. |     |   |   |   |

| Items           | Chain stroke [ft. and in.] | Length (L) [ft. and in.] | UL | Item no.           | Item no. with entrapment connection |
|-----------------|----------------------------|--------------------------|----|--------------------|-------------------------------------|
| Single actuator | 1 15/16" – 9 13/16"        | 1' 1 7/16"               | X  | WMX 503-1Gxxx*S ** | WMX 503-1Gxxx*E **                  |
|                 | 1 15/16" – 9 13/16"        | 1' 1 7/16"               | X  | WMX 803-1Gxxx*S ** | WMX 803-1Gxxx*E **                  |
| Double actuator | 1 15/16" – 9 13/16"        | 1' 1 7/16"               | X  | WMX 503-2Gxxx*S ** | WMX 503-2Gxxx*E **                  |
|                 | 1 15/16" – 9 13/16"        | 1' 1 7/16"               | X  | WMX 803-2Gxxx*S ** | WMX 803-2Gxxx*E **                  |
| Triple actuator | 1 15/16" – 9 13/16"        | 1' 1 7/16"               | X  | WMX 503-3Gxxx*S ** | WMX 503-3Gxxx*E **                  |
|                 | 1 15/16" – 9 13/16"        | 1' 1 7/16"               | X  | WMX 803-3Gxxx*S ** | WMX 803-3Gxxx*E **                  |
| Quad actuator   | 1 15/16" – 9 13/16"        | 1' 1 7/16"               | X  | WMX 503-4Gxxx*S ** | WMX 503-4Gxxx*E **                  |
|                 | 1 15/16" – 9 13/16"        | 1' 1 7/16"               | X  | WMX 803-4Gxxx*S ** | WMX 803-4Gxxx*E **                  |

\* 1 15/16" – 9 13/16", in increments of 25/64" (050 = 25/64")

\*\* The actuator can be supplied with certification according to UL 325 – see column UL.

See also the table 'Product code composition' for further details as well as determination of final item no.

WMX 503 / 503 UL / 803 / 803 UL

# Chain actuator

| Brackets                          | Item no. |
|-----------------------------------|----------|
| Chain bracket with split          | WAB 860  |
| Window fitting for wooden windows | WAB 867  |
| Multi bracket                     | WAB 801  |
| Chain bracket for integrated WMX  | WAB 833  |

**See separate product sheets for further information.**

## Installation suggestion

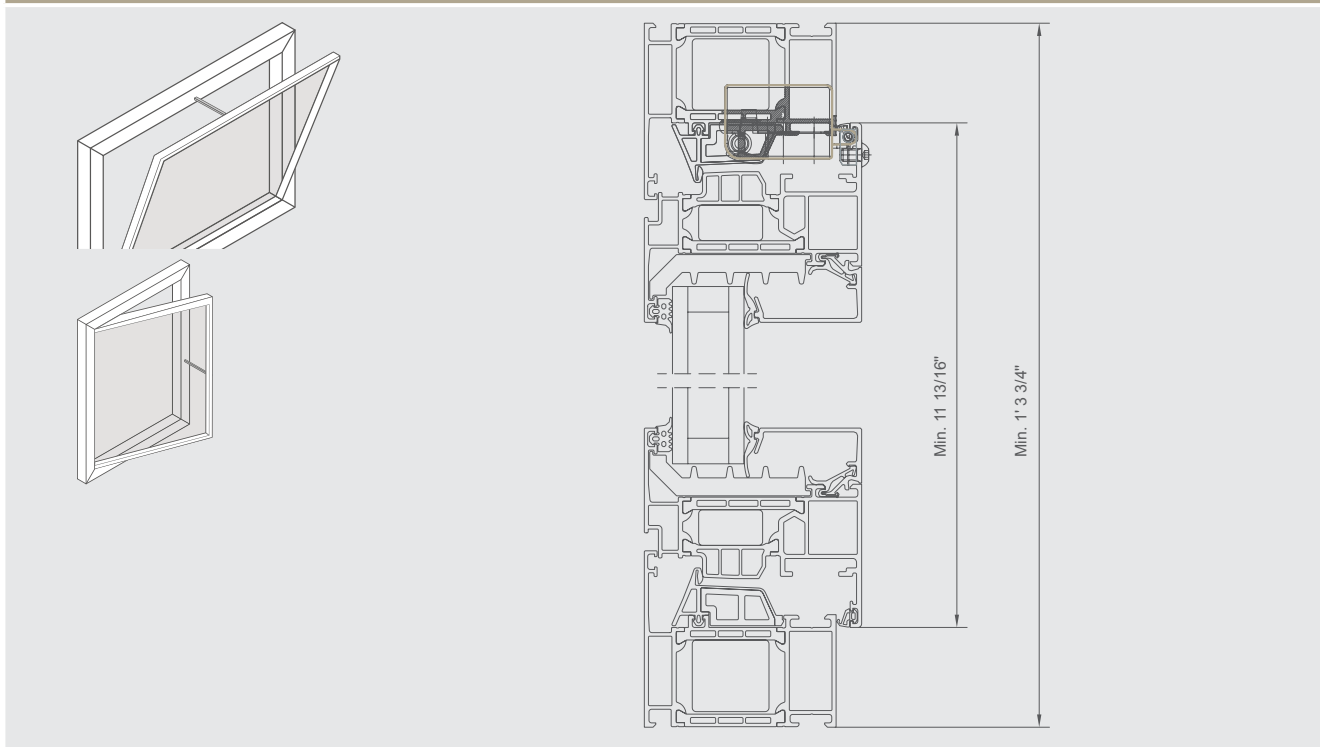

For questions regarding the concealed installation – contact WindowMaster

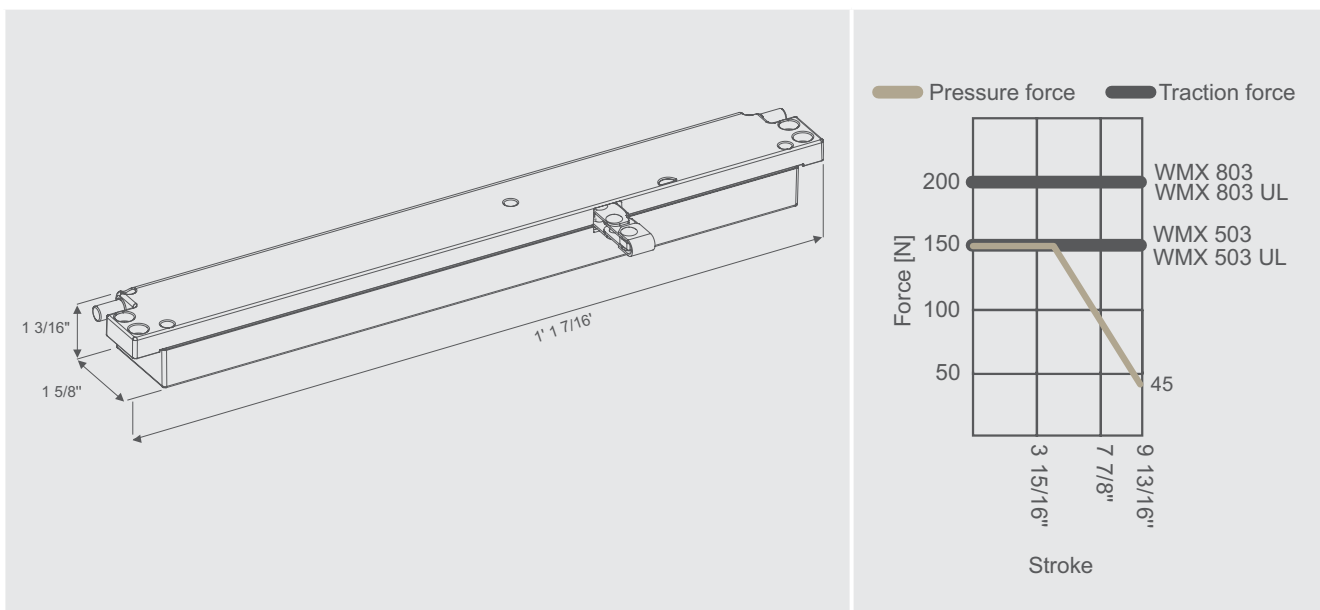

All dimensions are originally in metric units and converted into imperial units.  
For exact measurements please refer to documentation with metric values.

©WindowMaster 2013, 2023 ©WindowMaster is a registered trademark used under license by WindowMaster International

[windowmaster.com](http://windowmaster.com)