



WMS 409

## Spindle actuator 900N



Natural  
ventilation



Smoke  
ventilation



Smoke ventilation ±24V control  
EN 12101

24V

6.25

### Description

- for smoke and comfort ventilation
- approved according to EN 12101-2 with selected profiles – please contact WindowMaster for further information
- complete opening of the window within 60 sec. (depending on the programming)
- strong actuator suitable for roof openings
- to be used together with  $\pm 24V$  control units
- soft close function
- built-in electronic load switch-off/end stop
- electronic actuator with micro controller
- the actuator has an integrated reverse function to ensure a prolonged life span of the window gaskets
- easy mounting
- maintenance free through permanent lubrication
- outer parts corrosion-free
- heat resistant silicone connection cable

Technical specifications	
Pressure / Tractive force	900N / 900N
Locking force	2850N (break in force)
Spindle stroke	300, 500, 750 and 1000mm
Opening speed	12.5mm/s (full load)
Nominal voltage	24V DC (max. 10% ripple)
Voltage	19 - 32V DC
Open circuit voltage	Max. 32V DC
Current consumption	1.8A
Consumption of energy	Max. 44W
Operating conditions	-5°C - +74°C max. 90% relative humidity (not condensing)
Switch on duration	ED 30% (max. 3min. per 10min.)
Material	Aluminium
Colour	Aluminium EV1, other RAL-colour available at extra cost
Dimension	ø36mm, length (L) depending on spindle length - see table
Connection cable	5m grey connection cable in silicone 3-core 0.75mm <sup>2</sup> ø7.0mm
Weight	See table
IP rating	IP54 according to EN 50529
Life span	Tested with 10,000 opening and closing movements
EN certification	Approved according to EN 12101-2 with selected profiles – please contact WindowMaster for further information
Delivery includes	Spindle actuator with 5m connection cable
Note	We reserve the right to make technical changes

Stroke	Length (L)	Weight	Item no.
300mm	675mm	1,8	WMS 409 EN 0300 0103*
500mm	875mm	2,3	WMS 409 EN 0500 0103*
750mm	1125mm	2,7	WMS 409 EN 0750 0103*
1000mm	1375mm	3,1	WMS 409 1000 0103

\*For actuator approved according to EN 12101-2 the item number must contain EN.

Brackets	Item no.
Actuator bracket with clamping ring – 40mm	WSB 300 0001
Actuator bracket with clamping ring – 73 / 86mm	WSB 300 0002
Actuator bracket with clamping ring – 65mm	WSB 300 0003
Bottom screw	WSB 300 0004
Bracket with bolt and retaining cotter pin	WSB 300 0010
Bracket with fixing bolt	WSB 300 0011
Bracket with pin and retaining bracket	WSB 300 0012

See separate product sheets for further information.

Installation suggestion 1

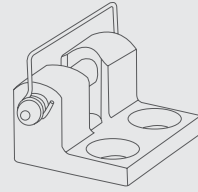
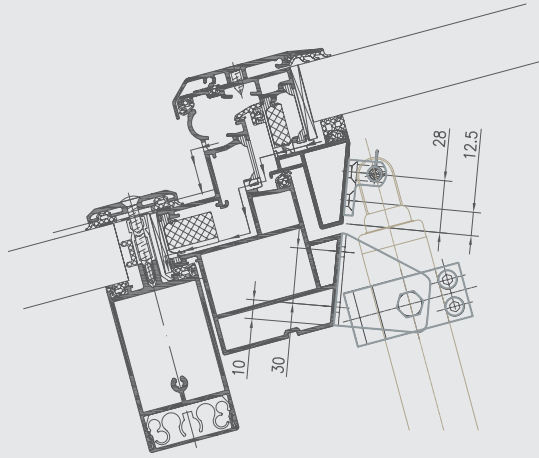

WSB 300 0012

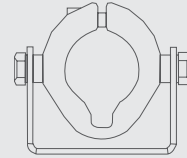

WSB 300 0001

Installation suggestion 2

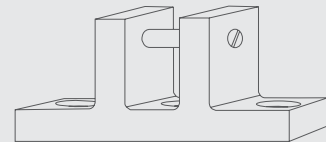
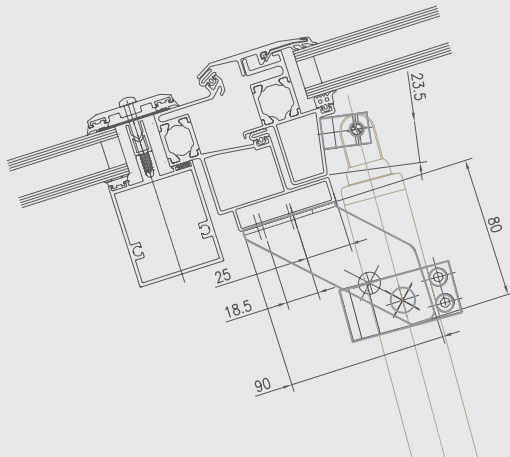

WSB 300 0011

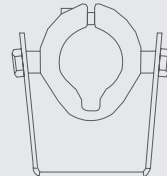

WSB 300 0003

Installation suggestion 3

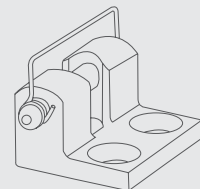
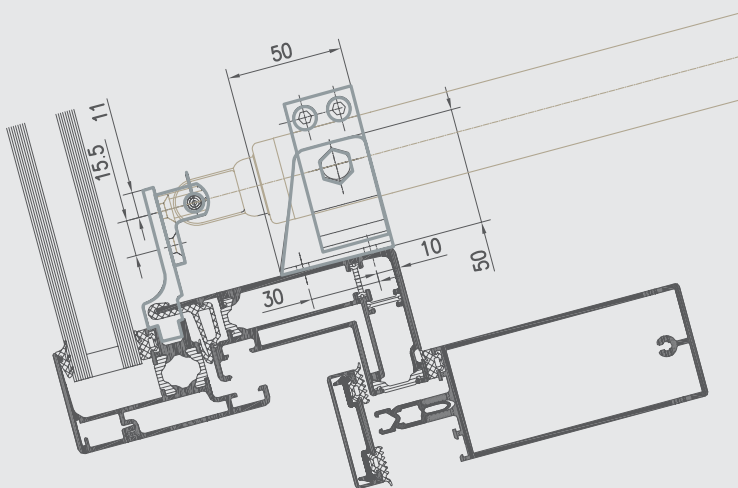

WSB 300 0012

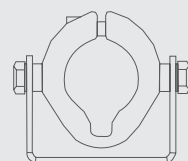

WSB 300 0001

WMS 409

# Spindle actuator 900N

