

# NV Solo®

## Control for one room / zone

Read instruction carefully before proceeding and keep for future reference (translated text).



Save this installation manual for the end user

The latest version of this document can always be found on our website

# Contents

<b>1. Description</b>	<b>3</b>
1.1 Delivery	3
1.2 Start-up	3
1.3 Connection	3
<b>2. Control panel</b>	<b>4</b>
2.1 Keys and symbols	4
2.2 Displaying wind speed	5
2.3 Manual operation	5
<b>3. Setting values for AUTOMATIC operation</b>	<b>6</b>
3.1 Indoor temperature	7
3.2 Outdoor temperature lock-out	7
3.3 Wind alarm	8
3.3.a Table: Wind speed	9
3.4. Rain alarm	9
3.5 Save the values SAV	10
<b>4. Basic settings</b>	<b>11</b>
4.1 Radio connection to the weather station	12
4.2 Wind and rain alarm, temporary or permanent	13
4.3 dAS	13
4.4 Operating setting LEAPOS or LEASP	14
4.4.A LEAPOS is selected	15
4.4.C CLR is selected	17
<b>5. Safety information</b>	<b>18</b>
<b>6. Weather station</b>	<b>19</b>
6.1 Description	19
6.2 Installation of the weather station	19
6.2.1 Sensor	19
6.2.2 Holder	20
6.3 Weather station mounting holes	20
6.4 Connecting the weather station	21
6.4.1 Printed circuit board	21
6.4.2 Connecting power	21
<b>7. Control panel</b>	<b>23</b>
7.1 Description	23
7.2 Placement of the control panel	23
7.3 Mounting holes on the control panel	23
7.4 Radio signal	23
7.5 Start-up ER	24
7.6 Testing sensors	25
7.6.1 Wind sensor	25
7.6.2 Rain sensor	25
7.6.3 Temperature sensor	25
<b>8. Maintenance</b>	<b>25</b>
8.1 Weather station	25
8.2 Control panel	25
8.2.1 Batteries	25
<b>9. Error messages</b>	<b>26</b>
9.1 Retrieving service data	27
<b>10. Technical data</b>	<b>27</b>
10.1 Control panel	27
10.2 Weather station	27
10.3 Factory settings	27
10.4 Personal setting data for AUTOMATIC operation	28
10.5 Examples of structures	28
10.6 Connection diagram for weather station	29
10.6.1 WCC 103 and WCC 106	29
10.6.2 WCC 3x0 Standard	30
10.6.3 WCC 3x0 Plus, WSC 3x0 Standard and Plus	31

# 1. Description

The NV Solo® weather station can automatically control opening and closing of windows in a room (a zone) in order to achieve the desired indoor climate.

## AUTOMATIC operation

- Opens the window at the selected indoor temperature
- Closes the window if the temperature falls below the selected outdoor temperature (outdoor temperature lock-out)
- Opens the window to the selected preset position (LEAPOS)
- Or the window opens modulated (selected opening time (LEASP))
- Closes the window at a selected wind speed (wind alarm, optional)
- Closes the window if it rains (rain alarm, optional)

The window closes when the temperature falls below the set indoor temperature or if a rain or wind alarm is registered.

## MANUAL operation:

The windows are operated manually using the control panel.

The wind and rain alarm is active, if it has been activated under AUTOMATIC operation.

## 1.1 Delivery

NV Solo® is comprised of a weather station and a control panel with 2 x 1.5V AA/LR6 batteries.

## 1.2 Start-up



Installation, testing and start-up of the window motor and the control unit are performed in compliance with applicable national legislation.

1. Setting values for basic settings (see point.4)
2. Setting values for automatic operation (see point.3)
3. Installation and connection (see points 6 & 7)

## 1.3 Connection

NV Solo® is connected to WindowMaster WCC control units by Natural Ventilation or WSC compact smoke panels for fire ventilation.

## 2. Control panel

### 2.1 Keys and symbols

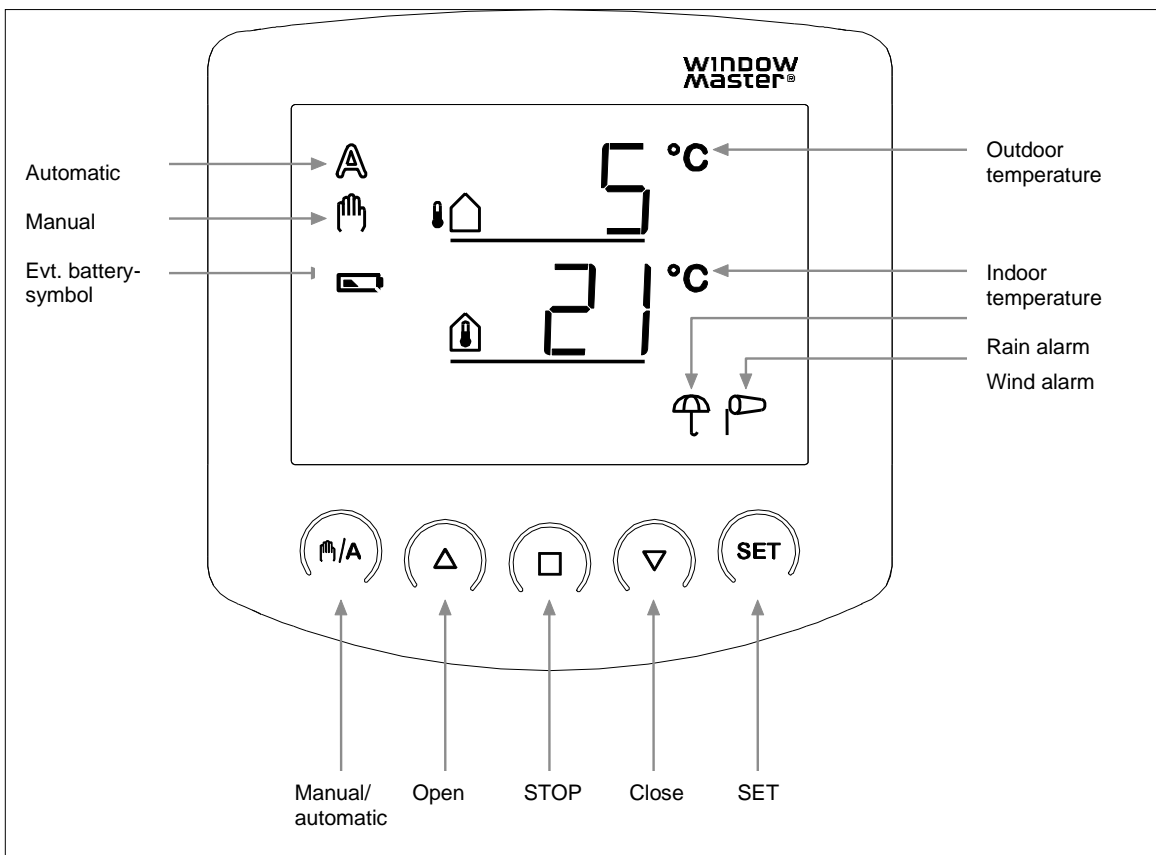

The control panel displays the control signals, outdoor and indoor temperatures, as well as rain or wind alarms. It also displays the operational setting and battery status. Weather data is updated every minute.



Outdoor temperature  
Shows the current outdoor temperature.



Indoor temperature  
Shows the current indoor temperature.



Battery symbol – half charged



Battery symbol - empty



AUTOMATIC operation

The window automatically opens and closes, as per the selected values for indoor and outdoor temperatures, wind speed and rain.



MANUAL operation

The window motor is operated manually using the arrow keys.



Wind alarm

When the wind alarm is active, the window will close when wind speeds higher than the alarm value are registered.



Rain alarm

When the rain alarm is active, the window will close if rain is registered.

## 2.2 Displaying wind speed

When the display shows the temperature, briefly press the **SET** key once and the display will then change to wind speed.

Briefly press the **SET** key again or wait approx. 60 seconds and the display will return to the temperature display screen.

Wind speed can be displayed in both AUTOMATIC and MANUAL settings.

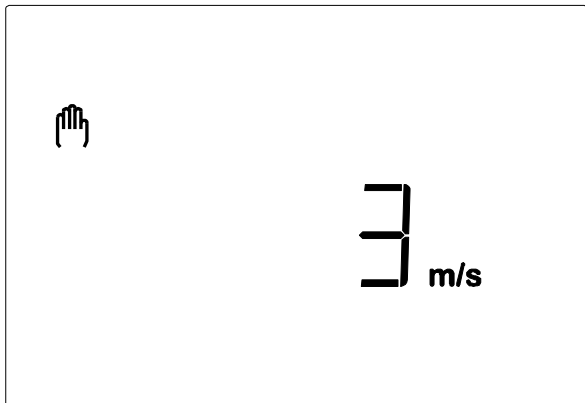

Note: The wind speed will not be displayed correctly for approx. 90 seconds after power has returned to the weather station (e.g. after a loss of power or at start up). If the wind alarm is activated, manual operation is blocked during this time.

## 2.3 Manual operation

The connected windows can be operated manually using the control panel keys.

AUTOMATIC operation is “switched off” and operation is no longer based on the indoor temperature.

The rain and wind alarms remain active if they are set to active in AUTOMATIC mode.

If the window is operated by using the  $\Delta$   $\nabla$  (arrow keys), the system will revert back to AUTOMATIC operation after 30 minutes.

If the  $\text{m}/\text{A}$  key has been pressed for operating in  $\text{m}$  (MANUAL operation), operation will remain in MANUAL until the system has been returned to AUTOMATIC control by pressing the  $\text{m}/\text{A}$  key.



**Open**



**stop**



**close**

The connected window can be operated manually using the  $\Delta$ ,  $\square$  and  $\nabla$  (open, stop, close) keys.

With a short press of the  $\Delta$  key (shorter than 1 second), the window opens completely.

With a long press of the  $\Delta$  key (longer than 1 second) the window opens as long as the  $\Delta$  key is pressed.

With a short press of the  $\nabla$  key, the window closes completely.

With a long press of the  $\nabla$  key, the window closes as long as the  $\nabla$  key is pressed.

Pressing  $\square$  stops the window motor.



### Manual/automatic

$\text{m}/\text{A}$  key switches between the AUTOMATIC **A** and MANUAL  $\text{m}$  operating modes. After manual operation using the  $\Delta$ ,  $\square$  or  $\nabla$  keys, the control system will be in MANUAL operating mode. Thus, AUTOMATIC operation is deactivated and control is no longer based on the temperature. Pressing the  $\text{m}/\text{A}$  key returns the system to AUTOMATIC operating mode.





A long press of the **SET** key switches to the setting of values for AUTOMATIC operation and two long presses switch to the setting of values in basic settings.

### 3. Setting values for AUTOMATIC operation

In order to achieve optimal ventilation, the values in AUTOMATIC operation must be adapted to the building conditions.

Press the **SET** key on the control panel () for at least 3 seconds to get to the programming of values for AUTOMATIC operation.

When the two symbols  and  are shown on the left of the display, the values can be changed (points 3.1 to 3.5).

If the programming setting is exited by pressing the  key or if the keys are not activated within 5 minutes, the programming setting will be exited and the entered settings will not be saved.

The control panel is in AUTOMATIC mode

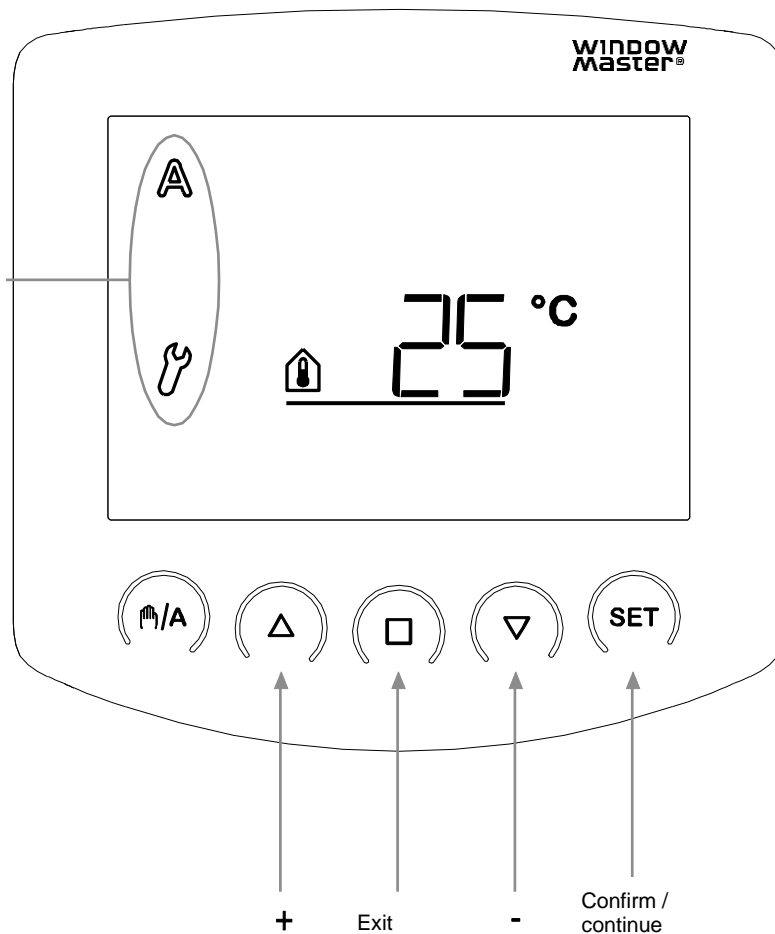

### 3.1 Indoor temperature

The first parameter that can be set is the indoor temperature, i.e. the interior temperature at which the window shall open. The indoor temperature is pre-programmed to 25°C.

If the interior temperature is greater than this value the window will open, unless the outdoor temperature is lower than the set lock-out value (3.2) or a wind or rain alarm is registered (points 3.3 and 3.4).

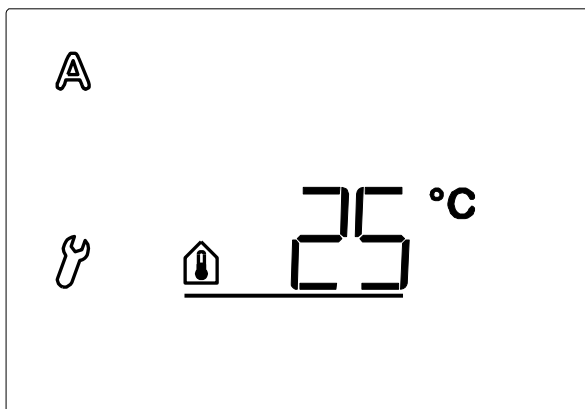

The indoor temperature has a hysteresis of 2°C, meaning the window will close again as soon as the indoor temperature drops with more than 2°C below the set temperature.

The indoor temperature symbol blinks.

The value is set using  $\Delta \nabla$ , or select OFF (found at +41°C and +4°C)

If OFF is selected, the system will not be controlled by temperature, which is why setting the exterior temperature lock-out (3.2) is skipped. The window can be operated manually and the wind and rain alarms are active if they have been set to active in AUTOMATIC operation (points. 3.3 and 3.4)

Confirm the selection by pressing the **SET** key. The display will automatically change to setup for the next parameter – outdoor temperature lock-out (point 3.2).

### 3.2 Outdoor temperature lock-out

The second parameter that can be set is the outdoor temperature lock-out. It is preset to 5°C.

The outdoor temperature lock-out is the temperature at which the window shall close if the temperature outside falls below the selected temperature. The lock-out shall also hold the window closed to prevent energy loss, even if the indoor temperature is exceeded.

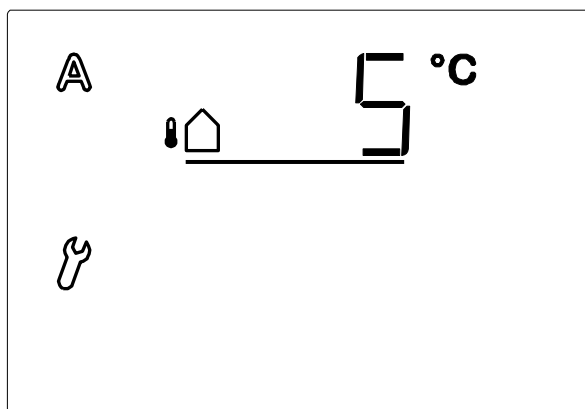

The hysteresis of the outdoor temperature lock-out is 2°C, meaning opening of the window is only enabled when the outdoor temperature is more than 2°C above the set temperature.

When the outdoor temperature symbol blinks, the value can be set using the  $\Delta \nabla$  keys or by selecting **OFF** (found at +21°C and -21°C)

If **OFF** is selected, the "Outdoor temperature lock-out" will be turned off.

Confirm the selection by pressing the **SET** key. The display will automatically change to setup for the next parameter – wind alarm (point 3.3).

The outdoor temperature lock-out should be set to a temperature *above* 0°C, if possible. If a window is opened while temperatures are *below* 0°C, frozen rubber seals can get damaged.

### 3.3 Wind alarm

The third parameter to be selected is whether the wind alarm shall be ON (active) or OFF (not active).

An active wind alarm prevents the window from being damaged. The wind alarm is factory pre-set to 4 m/s.

If an active wind alarm is selected, the window closes if the wind sensor registers wind speeds greater than the set value.

The window can still be operated using  $\Delta \nabla$ , but will return to AUTOMATIC operation after 2 minutes.

Table 3.3 can be used as a guide to finding the optimal value.

A wind alarm is maintained for 5 minutes. If the set wind value is exceeded by a new value during these 5 minutes, the period will begin again.

As long as a wind alarm is registered, the windssock symbol will be shown on the display.

RECOMMENDED SETTING; ACTIVE

If a non-active wind alarm is selected, the window will not close despite the high wind speeds.

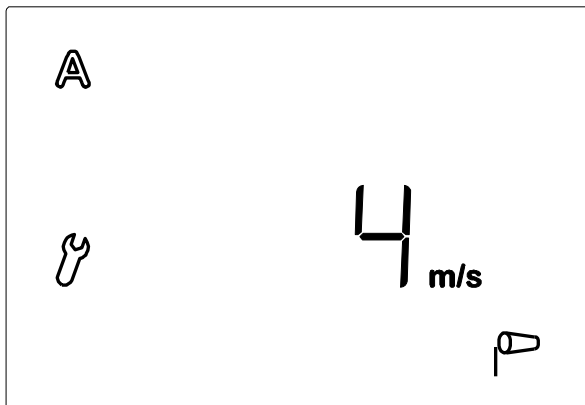

When the wind alarm symbol blinks, the value can be set using the  $\Delta \nabla$  keys or by selecting **OFF** (found at 21 m/s and 0 m/s).

If **OFF** is selected, the "Wind alarm" is not activated.

Confirm the selection by pressing the **SET** key. The display will automatically change to setup for the next parameter – rain alarm (point 3.4).



### 3.3.a Table: Wind speed

Description	m/s	km/hour	Beaufort scale	Knots
Calm	< 0.3	< 1.1	0	< 1
Light air	0.3-1.5	1.1-5.4	1	1-3
Light breeze	1.6-3.3	5.5-11.9	2	4-6
Gentle breeze	3.4-5.4	12.0-19.4	3	7-10
Moderate breeze	5.5-7.9	19.5-28.4	4	11-16
Fresh breeze	8.0-10.7	28.5-38.5	5	17-21
Strong breeze	10.8-13.8	38.6-49.7	6	22-27
Near gale	13.9-17.1	49.8-61.5	7	28-33
Gale	17.2-20.7	61.6-74.5	8	34-40
Severe gale	20.8-24.4	74.6-87.8	9	41-47
Storm	24.5-28.4	87.9-102.2	10	48-55
Violent storm	28.5-32.6	102.3-117.3	11	56-63
Hurricane	> 32.6	> 117.3	12	> 63

### 3.4. Rain alarm

The fourth parameter that can be set is whether the rain alarm shall be active **ON** or not active **OFF**.

An active rain alarm prevents water penetration. The rain alarm is pre-programmed to be active.

In active, the window closes if the rain sensor registers rain.

The window can still be operated using  $\Delta \nabla$ , but will return to AUTOMATIC operation after 2 minutes.

A rain alarm is maintained for 5 minutes. If precipitation is detected again during these 5 minutes, the period starts over again.

As long as a rain alarm is registered, the umbrella symbol will be shown on the display.

RECOMMENDED SETTING; ACTIVE

If a non-active alarm is selected, the window will not close even if it rains.



When the rain alarm blinks, select whether the alarm shall be active (**ON**) or non-active (**OFF**)

Using  $\Delta \nabla$ , select between **ON** and **OFF**.

Confirm the choice by pressing the **SET** key. The display will automatically change to setup for the next parameter – save the values (point 3.5).

### 3.5 Save the values SAV

Once the values in points 3.1-3.4 have been set, save the values (SAV=save) by pressing the **SET** key, and the display returns automatically to the indoor and outdoor temperatures.

If  is pressed here, you will exit SAV without saving the values.

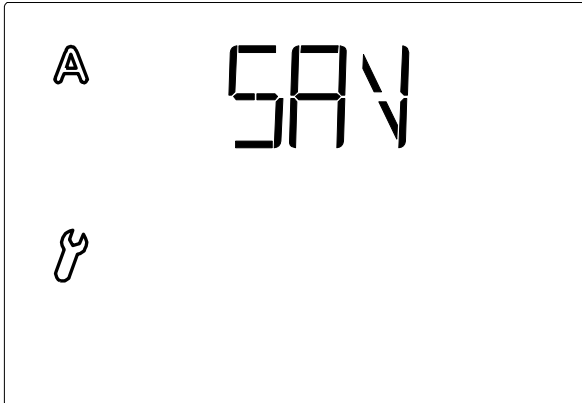

## 4. Basic settings

The basic settings are comprised of the radio connection to the weather station, operating settings for the wind and rain alarms, and the operating position for the open function.

To change the basic settings, press the **SET** key for at least 3 seconds. The two symbols **A** and  will be shown on the left side of the display.

Press the **SET** key again for at least 3 seconds. , CON and the antenna symbols will be shown in the display. The basic settings can now be set.

If the programming setting is exited by pressing the  key or if the keys are not activated within 5 minutes, the programming setting will be exited and the entered settings will not be saved.

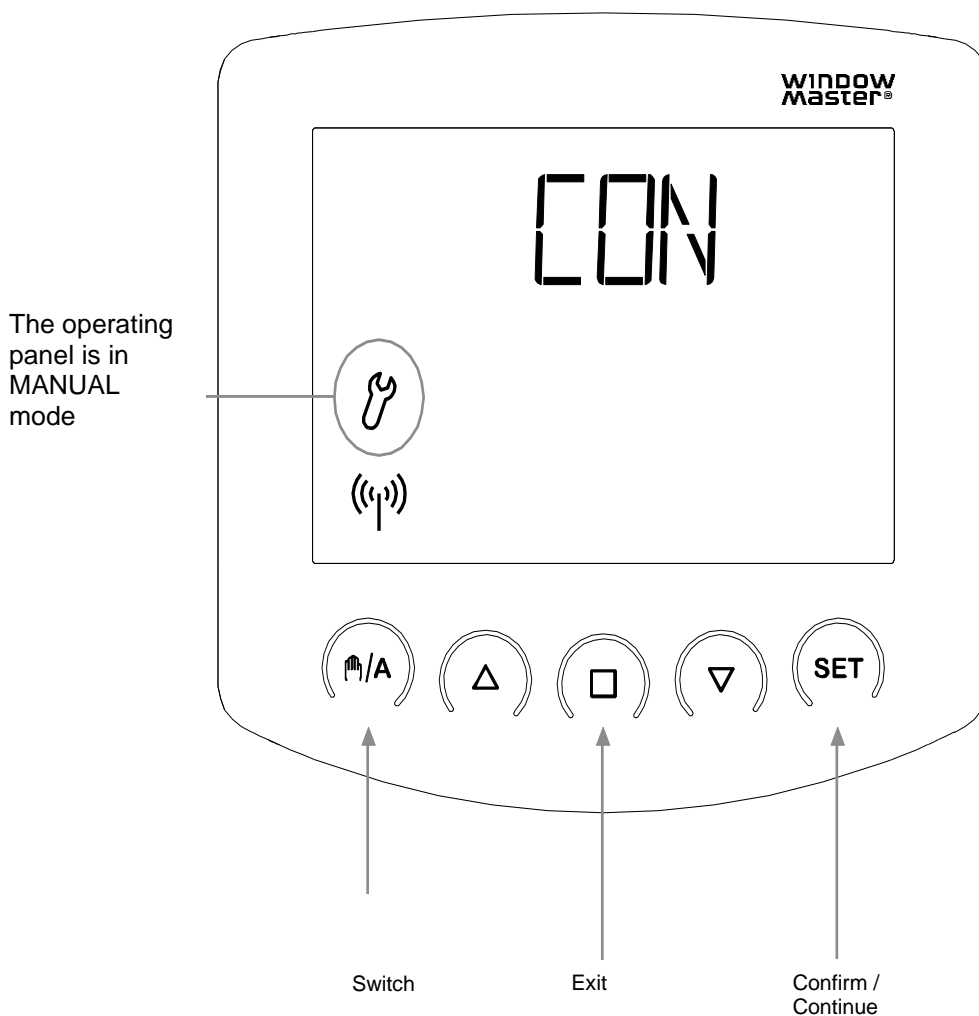

## 4.1 Radio connection to the weather station

The first parameter to be set-up is the radio connection between the control panel and the weather station.



The antenna blinks and the connection between the control panel and the weather station can be registered.

Press the /A key to select between LEA and CLR:

LEA (Lea=registers) to register a radio connection to the weather station  
CLR (Clear=delete) to delete an existing radio connection

Confirm the choice by pressing the **SET** key.

If LEA is selected; the radio symbol will stop blinking and the radio waves will begin to "run".

Press the orange programming key inside the weather station to establish the radio connection (see the photo of the weather station interior in point 6.4.1.b).

The connection has been established when the LED (the little white square) that is mounted above the programming key gives two short blinks. The display will automatically change to setup for the next parameter – wind and rain alarm (point 4.2)

If CLR is selected; the radio connection is deleted. The display automatically changes to **LEA** so that a new connection can be established. Then follow "If LEA is selected"

## 4.2 Wind and rain alarm, temporary or permanent

The second basic setting to be set is for a temporary or permanent wind and rain alarm.

The signal from the wind or rain alarm can be temporary (the signal to the control unit stops after 4 minutes - OFF) or permanent (continues as long as the rain sensor is wet or the wind sensor senses wind - ON).  
The alarm is factory set to ON.

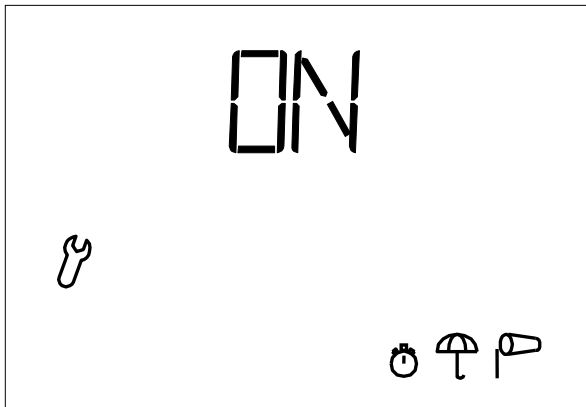

Select the desired setting ON or OFF using /A ;

**ON** The alarm signal shall be permanent (The window remains closed in the event of a rain or wind alarm).  
The control panel is factory set to ON. RECOMMENDED SETTING

**OFF** The alarm signal shall stop after 4 minutes

Confirm selection by pressing **SET**-key. The display will automatically change to setup for the next parameter – dAS (4.3).

## 4.3 dAS



The third basic setting to be set is dAS.

dAS is a function that makes it possible to use WindowMaster Smoke Ventilation Units WSC xxx.  
dAS is pre-set to be ON.  
RECOMMENDED SETTING: ON.

Confirm the selection by pressing the **SET** key. The display will automatically change to setup for the next parameter – operating setting (point 4.4).

## 4.4 Operating setting LEAPOS or LEASP

NV Solo® has two different operating settings LEAPOS and LEASP.  
The control panel is factory set to LEASP.

### LEAPOS:

The window opens to the set opening position each time the window opens in AUTOMATIC operation.  
The window closes when the temperature falls below the selected indoor temperature. The temperature is registered every 4 minutes.

To set the opening position, see point 4.4.a.  
To set the indoor temperature, see point 3.1

### LEASP:

The window opens modulated, i.e. with a fixed run time, every time the window opens in AUTOMATIC operation.

The temperature is recorded;

1. If the temperature is too high, the window will open. If the temperature has not fallen sufficiently the next time the temperature is checked, the window is opened further with the fixed run time. This is repeated until the desired indoor temperature is reached. This is however conditional on the maximum chain length of the window motor not being exceeded.
2. If the temperature is too low and the window is open, the window will close modulated until the temperature falls below the selected indoor temperature.

The run time is factory set to 5 seconds. To set the run time, see point 4.4.b.

The time interval for temperature registration is factory set to 7 minutes. To set the interval time, see point 4.4b  
To set the indoor temperature, see point 3.1

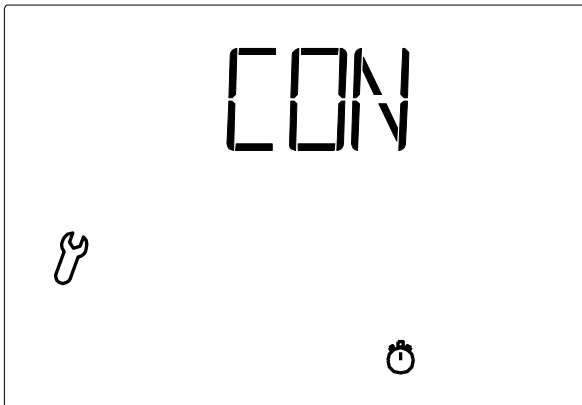

CON is displayed and the clock blinks

Press the /A key to select between CON, LEAPOS, LEASP and CLR:

**CON** (Continue) to skip individual setting of the opening position, run time and control interval time.  
NV Solo® will then use the factory set values.

**LEAPOS** (Learn POS=read position) to record the selected opening position

**LEASP** (Learn STEP=set interval) to set the run time and interval time

**CLR** (Clear) Deletes the values entered and uses the factory set values (run time 5 sec. / interval time 7min.)

Confirm the choice by pressing the **SET** key.

If both LEAPOS and LEASP are set, the last set operational setting is followed.

#### 4.4.A LEAPOS is selected

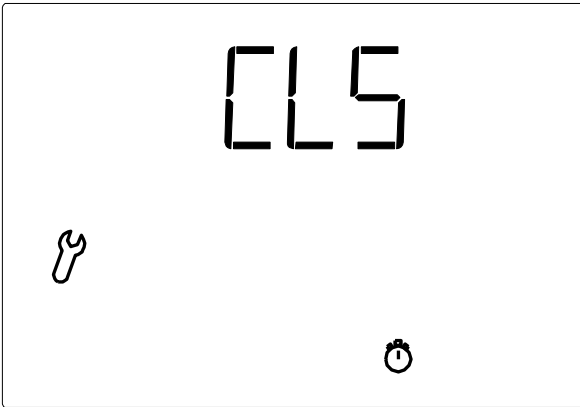

1. The display shows **CLS** (CLS=close) and the clock blinks.
2. Close the window completely by holding down **▽**
3. When the window is completely closed, press the **SET** key. The display automatically changes to set up for the next parameter– determining the fixed open position (OPN)

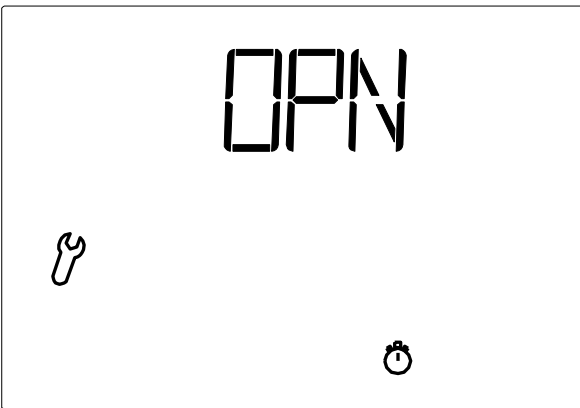

1. The display shows OPN and the clock blinks
2. Hold down **△** (open) until the desired "Fixed open position" is reached
3. Confirm the selection by pressing the **SET** key. The display will automatically change to setup for the next parameter – SAV.



1. The display shows SAV (save).
2. Confirm the selection by pressing the **SET** key. The display will automatically change to display the indoor and outdoor temperatures.
3. The system is operating in manual setting. Change if necessary to AUTOMATIC operation **A**

Setting the basic settings can be exited by pressing **□** and the changed settings will not be saved.

After the settings in the basic settings have been set and saved, the values for AUTOMATIC operation can be adjusted. Test the sensor function the first time this function is used, (point 7.6).

#### 4.4.B LEA<sub>SP</sub> is selected

After confirmation of LEA<sub>SP</sub>;

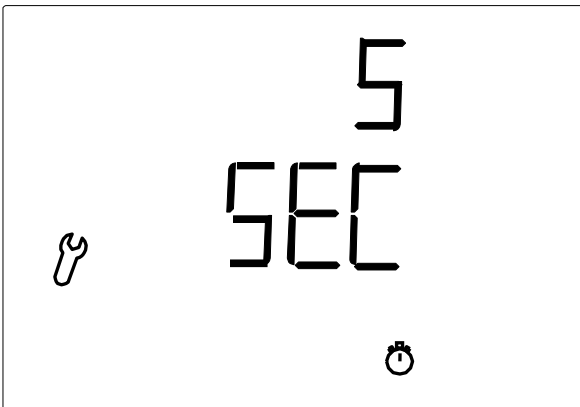

1. The display shows the run time “5 sec.” and the clock blinks.
2. Set the time using  $\Delta\nabla$ .
3. Confirm the selection by pressing the **SET** key. The display will automatically change to setup for the next parameter – control-interval time

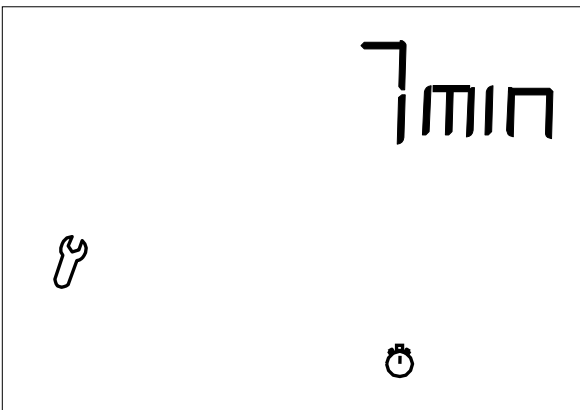

1. The display shows the control-interval time 7 min. and the clock blinks.
2. Set the time using  $\Delta\nabla$
3. Confirm the selection by pressing the **SET** key. The display will automatically change to setup for the next parameter – save (SAV)



1. The display shows SAV (save).
2. Press the **SET** key to save the entries. The display will change to display the indoor and outdoor temperatures.
3. The system is operating in manual setting. Change if necessary to AUTOMATIC operation **A**



If  is pressed, the basic settings are exited and the changed values are not saved.

After the settings in the basic settings have been set and saved, the values for AUTOMATIC operation can be adjusted. Test the sensor function the first time the function is used (point 7.6).

#### 4.4.C CLR is selected

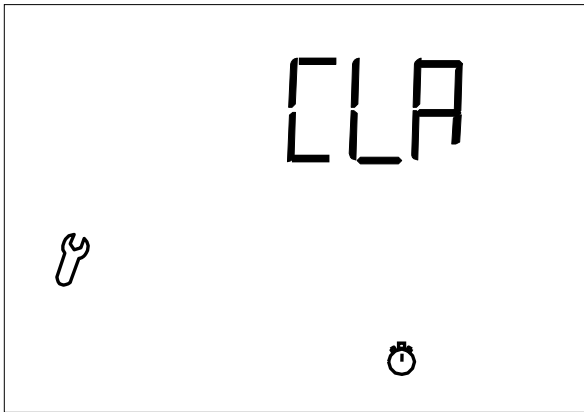

1. The display shows CLR (CLS=clear) and the clock blinks.
2. Confirm the selection by pressing the **SET** key. The display will automatically change to setup for the next parameter – save (SAN)



1. The display shows SAN (save).
2. Confirm the selection by pressing the **SET** key. The display will automatically change to display the indoor and outdoor temperatures.
3. The system is operating in manual setting. Change if necessary to AUTOMATIC operation **A**
4. In automatic operation, the window will now open/close per the factory set values, run time 5 sec. and temperature check every 7 minutes.

## 5. Safety information

In the event of a power failure to the weather station, the control unit can no longer control the connected window motor!

The settings that are stored in the control panel are saved in the event of a power failure.

When the power returns, the controls go into AUTOMATIC operation.

If the radio connection between the control panel and the weather station is interrupted (e.g. if there are disturbances with the radio connection or because the batteries in the control panel are empty), the window cannot be operated manually. The system continues in AUTOMATIC operation without regard for the indoor temperature until the radio connection is re-established. The wind and rain protection functions are maintained if they were set to active before the power failure.

If it begins to rain, it may take some time before the weather station sounds the alarm, depending on the outdoor temperature and the amount of rainwater. Closure time shall also be added for electrically powered windows. Therefore, objects that are sensitive to moisture should not be placed in the area as they can be damaged if water flows in.

Note that the windows, e.g. in the event of a power failure, do not automatically close if there is a rain alarm unless an emergency power system is connected.

### Safety instructions

- Make sure that the window is in suitable condition for electric operation. It is recommended to grease window hinges at least once a year after installation of the motor unit.
- **ATTENTION!** To avoid personal injury during installation, do not connect motor to power supply until installation is complete.
- Electrically operated windows may cause personal injury if body parts are caught within the operating area of the window. Where there is a risk of personal injury or a situation where children are involved, it is recommended that the operation mode where the motor will run only as long as the keypad button/switch is pressed be set to manual. In the automatic mode, because of the tractive capacity of the system, the risk of personal injury will be increased. Never leave children in charge of window operation.
- NV Solo® is a 24 V DC product and must not be connected to the mains voltage, as it thereby will be damaged.
- NV Solo® should not be fitted to a window, which is used for emergency escape/access.
- Make sure that mains voltage is disconnected when cleaning or other maintenance/service of the window is being undertaken, and ensure that it cannot be unintentionally reconnected.
- Window actuators for smoke ventilation: If the window actuator has been exposed to temperatures above 90 °C it has to be checked by a WindowMaster technician.
- The packing can be disposed of together with ordinary household waste. The product must be disposed of in conformity with national regulations for electronic waste and not with usual household waste.
- In case of technical problems, please contact WindowMaster, see telephone list.

## 6. Weather station

### 6.1 Description

The weather station is supplied with power from a WCC control unit or from the WSC compact central. It communicates with the weather station via a radio connection.

### 6.2 Installation of the weather station

#### 6.2.1 Sensor

The sensor shall be mounted on the building so that the sensor can collect wind and rain unhindered. The weather station must **not** be overshadowed by buildings, trees or similar. There must be a free area of at least 60cm below the weather station to allow for correct wind measurement and to avoid it being covered with snow.

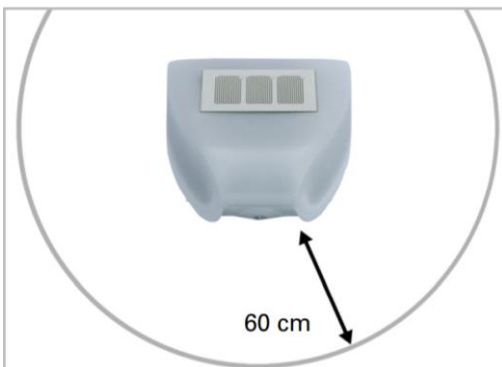

There must be at least 60cm of space below, to the sides and in front of the weather station left from other elements (structures, construction parts etc.)

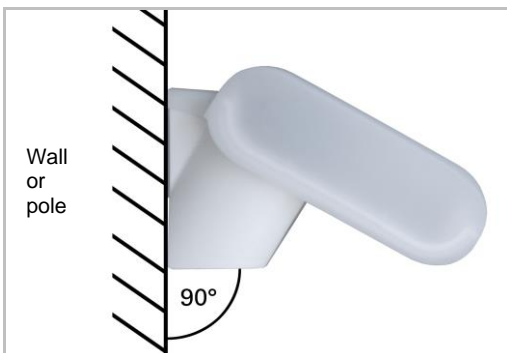

The weather station must be mounted on a vertical wall (or a pole).



The weather station must be mounted in the horizontal transverse direction (horizontally).

### 6.2.2 Holder

The weather station includes a combined holder for wall/pole mounting. At delivery, the holder is mounted on the sensor.

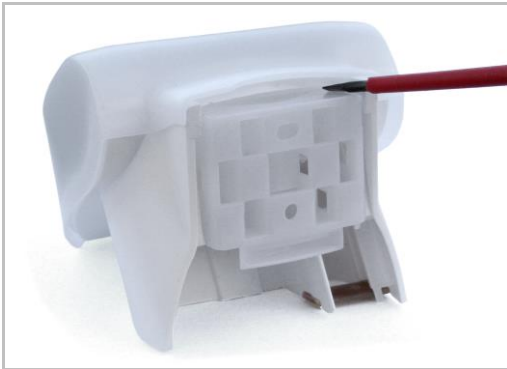

6.2.2.a Remove the holder using a screwdriver

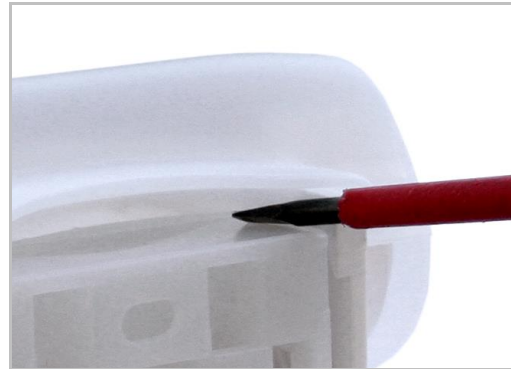

6.2.2.b Push the holder downwards and out

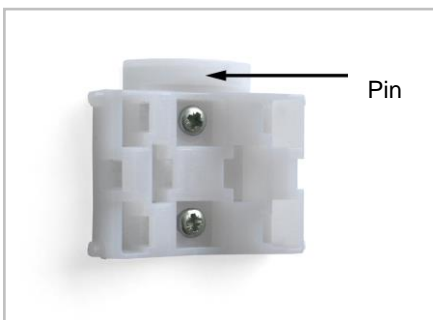

When mounting vertically on the wall, place the flat side in toward the wall with the half-moon shaped pin upward.

6.2.2.c

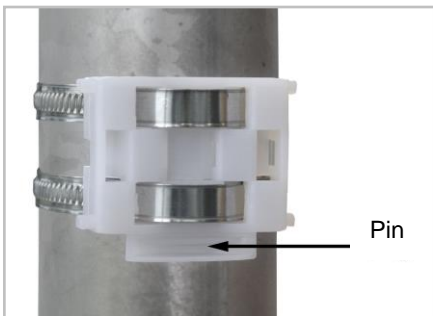

When mounting vertically on a pole, mount with the curved side in toward the post and the pin downward

6.2.2.d

### 6.3 Weather station mounting holes

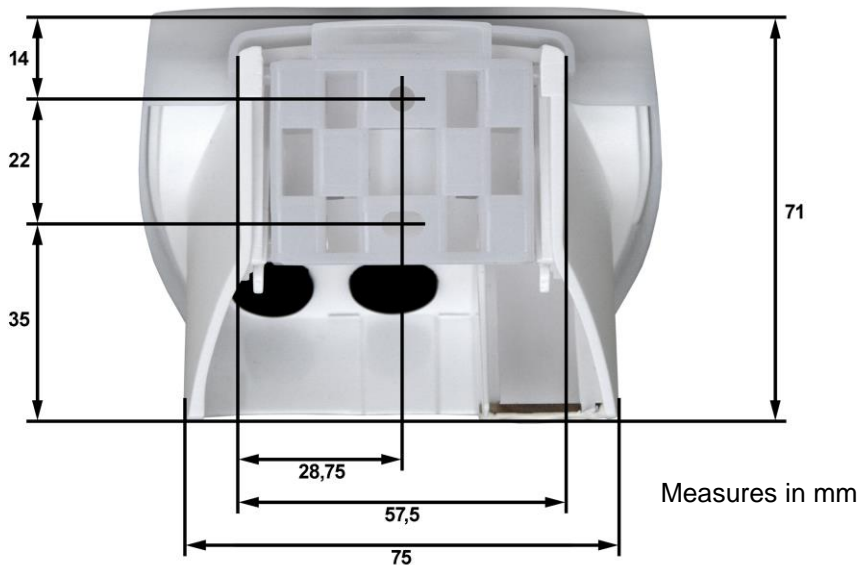

## 6.4 Connecting the weather station

### 6.4.1 Printed circuit board

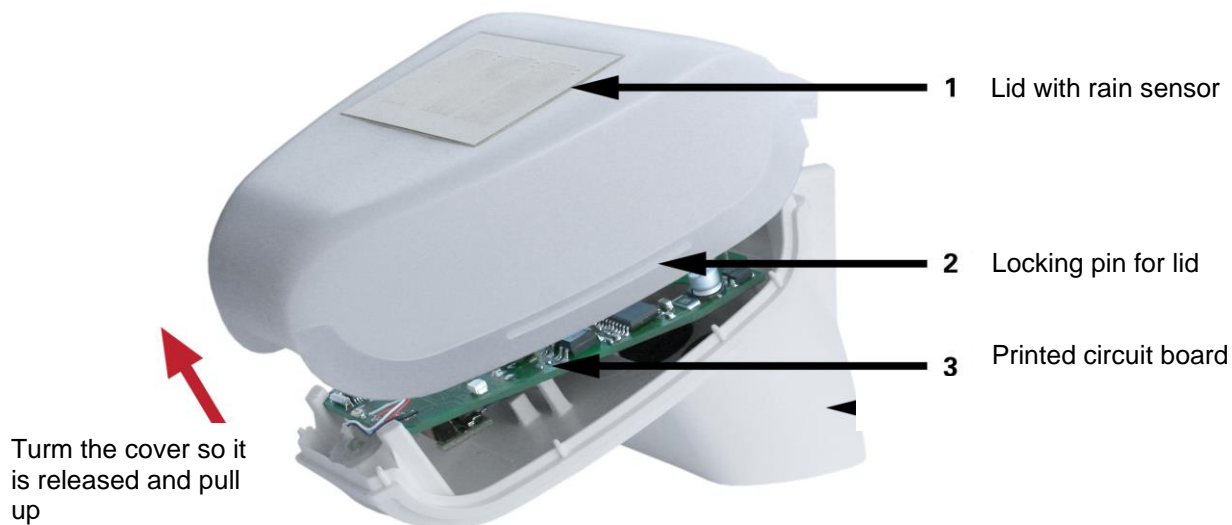

6.4.1.a

The lid of the weather station, on which the rain sensor is mounted, is clamped on the right and left sides (see picture 6.3.a.1).

Remove the lid from the weather station. Be careful that you do not pull the cable connection between the rain sensor in the lid and the underside of the Printed circuit board

The weather station must not be opened if water could enter. Just a few drops are enough to damage the electronics.

Ensure that it is always connected correctly. Incorrect connection can damage the weather station electronics. Ensure that the temperature sensor (the small printer on the underside of the box) is not damaged during mounting.

Ensure that the connecting cable between the printed circuit board and the rain sensor is not pulled off or broken during connection.

### 6.4.2 Connecting power

The window actuator on the window is connected to the control unit. Multiple window actuators can be connected parallel to the control unit. Note that control unit's maximum capacity.

To connect a window actuator to the WCC system unit or to the fire alarm WSC, we refer to their guidelines.

Guide the cable from the control unit to the weather station through the rubber washer on the rear of the weather station. Connect the voltage (24V / 0V) and connect the signal cables on the clamps (3, 2, and 1).

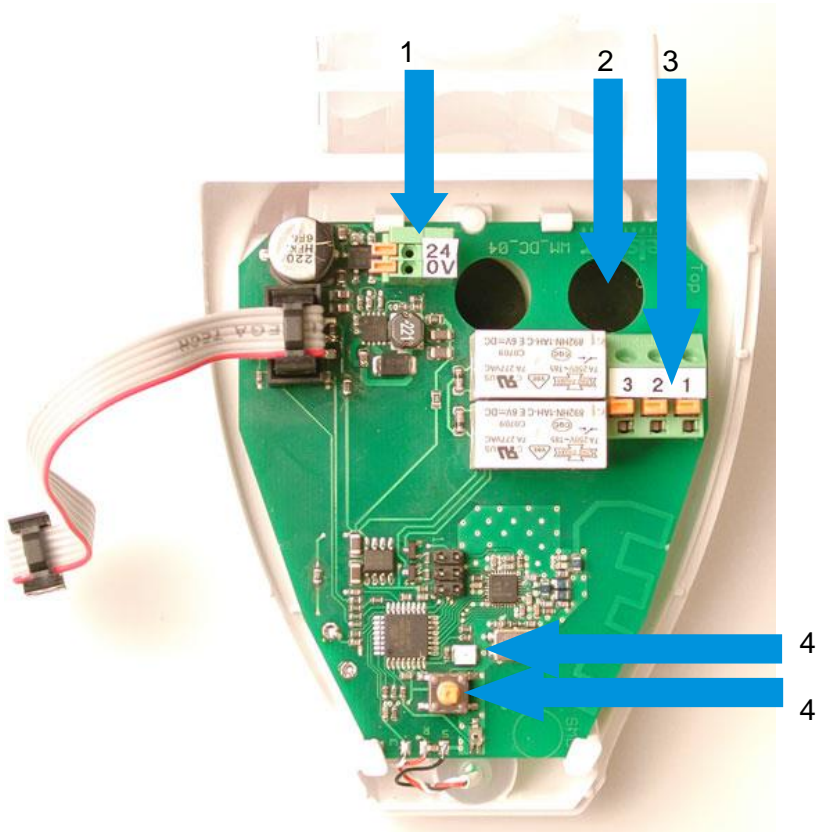

6.4.1.b

1. Contact for power supply 24 V DC
2. Opening to cable for power supply
3. Contact for signal cables (3=Close, 2=Open, 1=COM)
4. In normal operation, this LED indicates reception of signal by a short blink.
5. Programming key for registering the radio connection to the operating unit.

Close the box by pressing the lid firmly onto the bottom of the box. The lid must be pushed in with a clear “click” on both the right and left sides

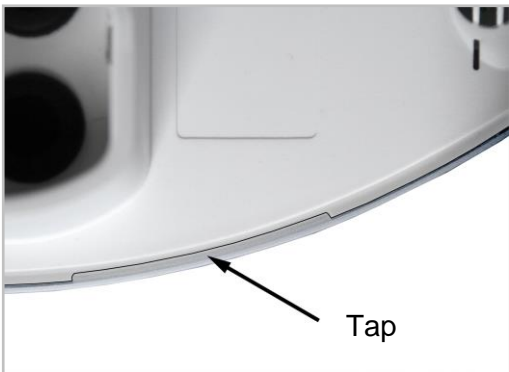

6.4.2.a

Test to ensure the lid and the bottom part are tightly fitted together. The image shows the underside of the closed weather station.



6.4.2.b

The sensor is pushed down over the mounted holder device, and the pins for the holder should be locked in the box's rails.

## 7. Control panel

### 7.1 Description

The control panel is battery operated and communicates with the radio via a radio connection with the weather station.

### 7.2 Placement of the control panel

Select an installation location that is not exposed to direct sunlight; otherwise measurement of the indoor temperature will not be correct.

The temperature sensor is built into the underside of the control panel. The control panel should not be mounted over a radiator for the same reason. Ensure that direct drafts from windows or doors do not give incorrect measurements.

Max. Distance between the control panel and the weather station:

- In open field up to 200m
- Inside buildings through 2 floors made of concrete with iron (no guaranties)

If the control panel and the weather station cannot get in contact place the control panel 10cm beside the current location.

### 7.3 Mounting holes on the control panel

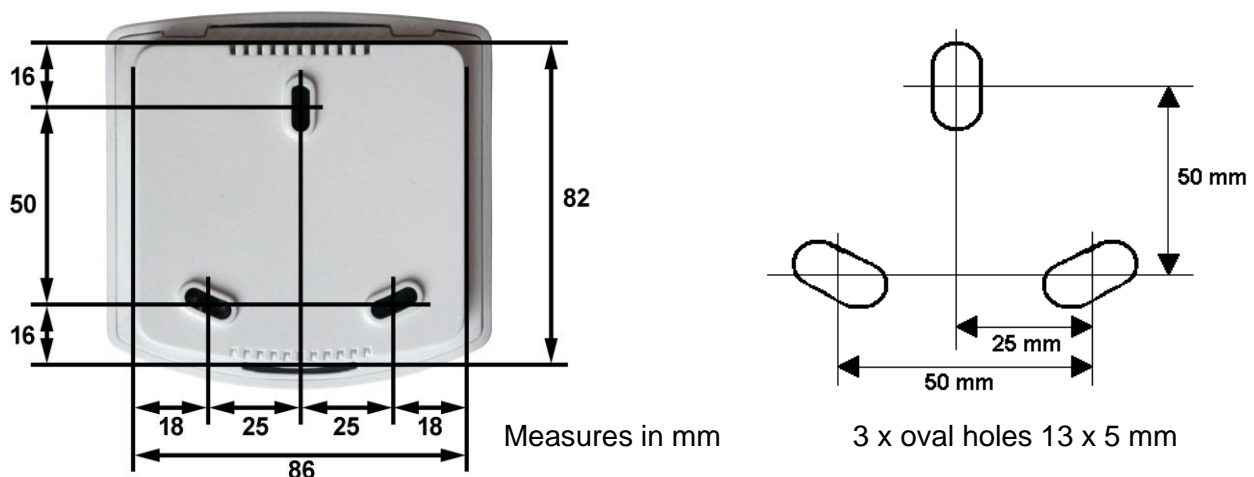

### 7.4 Radio signal

During planning, consideration should be given to adequate signal reception. The range of the radio unit is limited by legislation for radio equipment, as well as the condition of the building, the walls and ceilings of which the radio signal will pass through.

In order to avoid the reception quality from being affected, there should be a distance of at least 30 cm between radio transmitters. Thus, both the control panel and weather station should be placed at a sufficient distance from other radio transmitters. Strong local transmission devices, such as headsets, which send on the same frequency (868.2 MHz), can impair reception. The control panel should never be mounted in the immediate proximity of metal surfaces.

## 7.5 Start-up ER

1. Turn on the power to the control unit.
2. Place the batteries in control panel (point 8.2.1).
3. ER = error and the antenna symbol are shown on the control panel display, i.e. there is no radio connection between the weather station and the control panel.

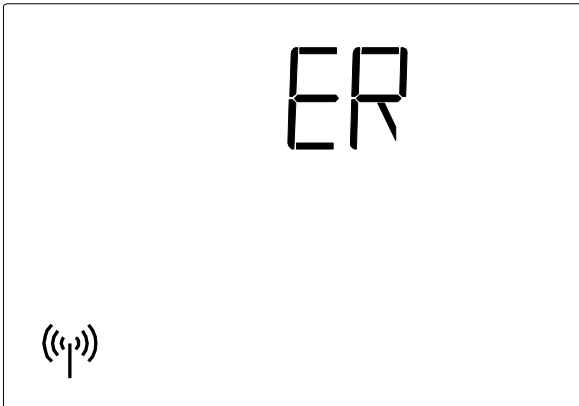

7.5.a

4. Press the **SET** key for 3 secs. until the display shows; **A**, **U** and the antenna symbol

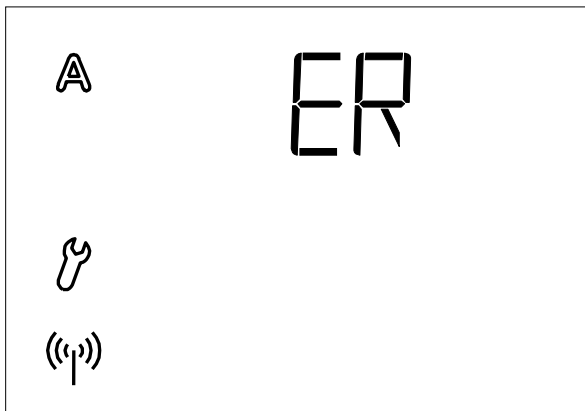

7.5.b

5. Press the **SET** key again for at least 3 seconds.
6. The display shows CON, **U** and the antenna symbol blinks.
7. The connection between the control and weather station can be registered. Follow the guidelines from point 4.1 – Radio connection to the weather station

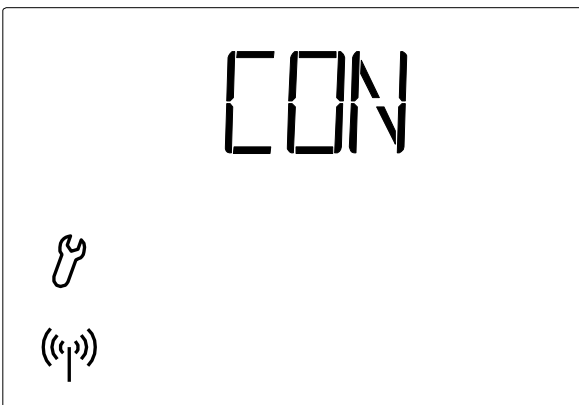

7.5.c

8. Then test the sensor function (points 7.6.1 – 7.6.3).



## 7.6 Testing sensors

Test the sensor function (points 7.6.1 – 7.6.3).

If an error occurs with the sensor function during the use of NV Solo®, error messages will be displayed (see point 9) instead of values

### 7.6.1 Wind sensor

The wind speed is displayed by a short press on the **SET** key in the control panel. 2.2).

The sensor tube is placed in front on the underside of the weather station. When wind blows into the pipe, the value on the display changes.



Be aware that the wind speed is not displayed correctly for approx. 90 seconds after power has returned to the weather station (e.g. after a loss of power or at start up).

### 7.6.2 Rain sensor

Slightly dampen one or more of the golden sensor surfaces on the weather station. The umbrella symbol will be shown on the display (rain alarm) in association with this, the rain alarm shall be set to active in the automatic settings. The control panel is pre-programmed to ON (point 3.4)

Note that the rain alarm is maintained for 5 minutes after the sensor has dried.

### 7.6.3 Temperature sensor

If the values in the display at the side of the symbols   (outdoor temperature) and  (indoor temperature) look fine, you can assume that the function is operating correctly

## 8. Maintenance

### 8.1 Weather station

The weather station should be checked regularly for dirt and cleaned if needed. A lot of dirt can impair the wind sensor's function, and may contribute to the non-detection of a rain message.

In the event of a power failure, the entered data is saved for almost 10 years. No battery is required.

### 8.2 Control panel

Clean the control panel as needed, using a cloth wrung out in water mixed with a mild cleaner.

#### 8.2.1 Batteries

The battery chamber is located inside the control panel.

The control panel is opened by opening the lock on the under edge of the panel. This is done by pressing a screwdriver into the hole at the front.

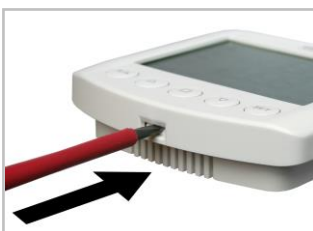

2 standard batteries are used, either 1.5 or 1.2 V type AA (Mignon/LR6).

Close the unit by hooking the front plate with the printer into the rearmost part at the top. Push in and lock, the lock will make a clear click

## 9. Error messages

Instead of values for temperatures or wind speeds, error messages may be shown in the display

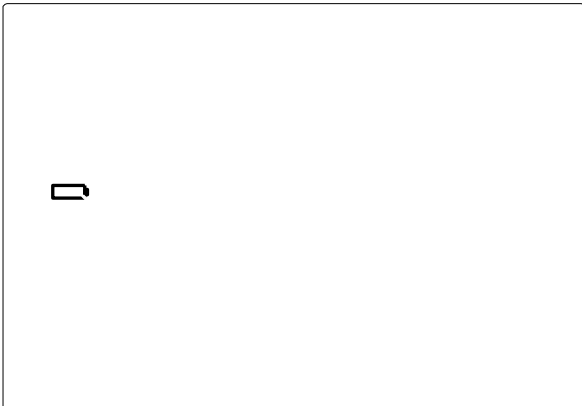

**Error:**

A battery and no other symbol is shown  
Manual operation possible for a *short* time

**Cause:** Batteries in the control panel are almost completely empty and must be changed.

Note: The operational reliability of the control panel is no longer guaranteed.

**Procedure:** Change the batteries (see point.8.2.1).

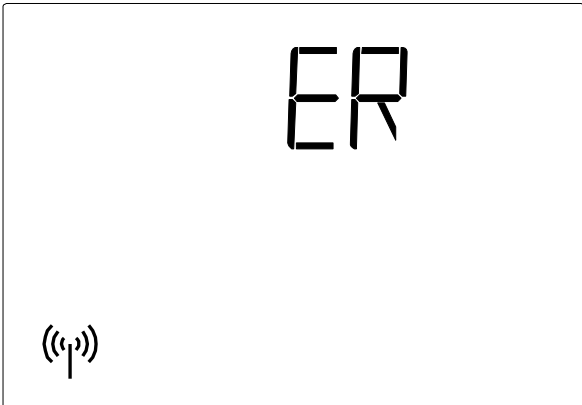

**Error:**

**ER** and the radio symbol is shown in the display.

**Cause:** No radio connection between the control panel and weather station. The weather station is not in operation (e.g. there is no power), or a radio connection is broken or has not been registered.

**Procedure:** Register the radio connection between the weather station and the operating panel Follow point 4.1

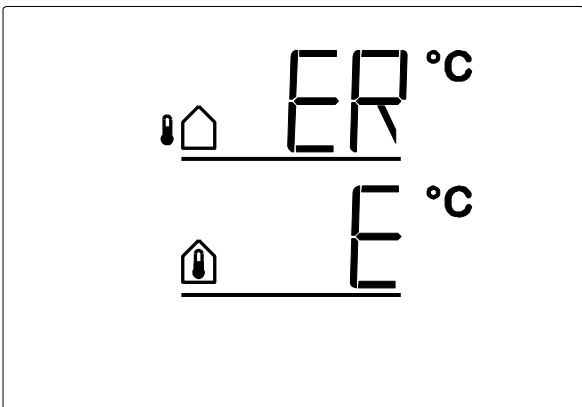

**Error:**

**ER** instead of outdoor temperature  
**E** instead of indoor temperature.

**Cause:** The weather station sensor for measuring outdoor temperatures or the control panel sensor for measuring indoor temperature is defective.

**Procedure:** Replace the weather station or operating panel

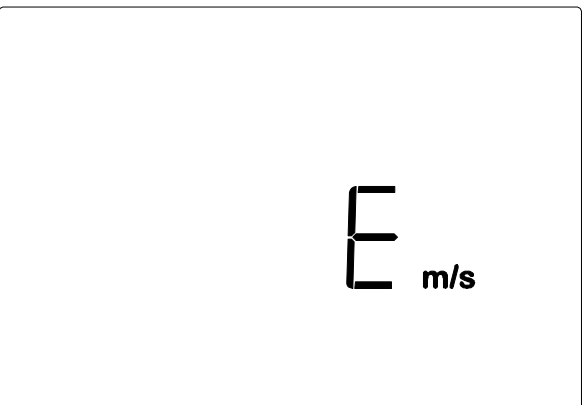

**Error:**

**E** instead of wind speed

**Cause:** The weather station's sensor for wind measurement is defective.

**Procedure:** Replace the weather station

## 9.1 Retrieving service data

The software version of the control panel and weather station may appear in the display. Access to the service area via the basic settings takes place by one long press on the **SET** key (3 seconds). First, the software edition of the control unit (**PAN**, Panel) is displayed and afterwards a short press of the **SET** key displays the software edition of the control unit/weather station (SEN=sensor). The number 10 in the display indicates version 1.0, 12 indicates 1.2, etc. Exit the service data display by pressing the **SET** key shortly.

## 10. Technical data

The product is in conformity with the provision of EU directives.

### 10.1 Control panel

Voltage	2 x 1.5 V (2 batteries, AA/Mignon/LR6) or 2 x 1.2 V (2 batteries, AA/Mignon/LR6)
Surrounding temperature	-10°C to +50°C
Dimensions of control unit	103 x 98 x 28mm (WxHxD)
Frequency	868.2 MHz
Note:	We reserve the right to make technical changes

### 10.2 Weather station

Voltage	13-30V DC / 12-24 V AC
Surrounding temperature	-30°C to +60°C
Weather station dimensions	96 x 77 x 118mm (WxHxD)
Output	Potential free contacts to input on control unit (WCC / WSC)
Heating rain alarm	approx. 1.2 W
Measuring range of temperature sensor	-40°C to +80°C
Accuracy of temperature sensor	0.6°C
Measuring range of wind sensor	0 - 35m/s
Accuracy of wind sensor	1 m/s
Backup time	10 years
Note:	We reserve the right to make technical changes

### 10.3 Factory settings

The control panel is pre-programmed with:

- Opening at indoor temperature > 25°C
- Lock-out at outdoor temperature >5°C
- Wind alarm from 4 m/s
- Rain alarm is activated (ON)
- Run time 5 seconds (LEASP)
- Interval time 7 minutes (LEASP)
- dAS is activated (ON)

### 10.4 Personal setting data for AUTOMATIC operation

Opening at indoor temperature above		°C
Outdoor temperature lock-out below		°C
Wind alarm		m/s
Rain alarm		(Yes/No)
Opening position		cm
Run time		Sec.
Control time temperature		Sec.

### 10.5 Examples of structures

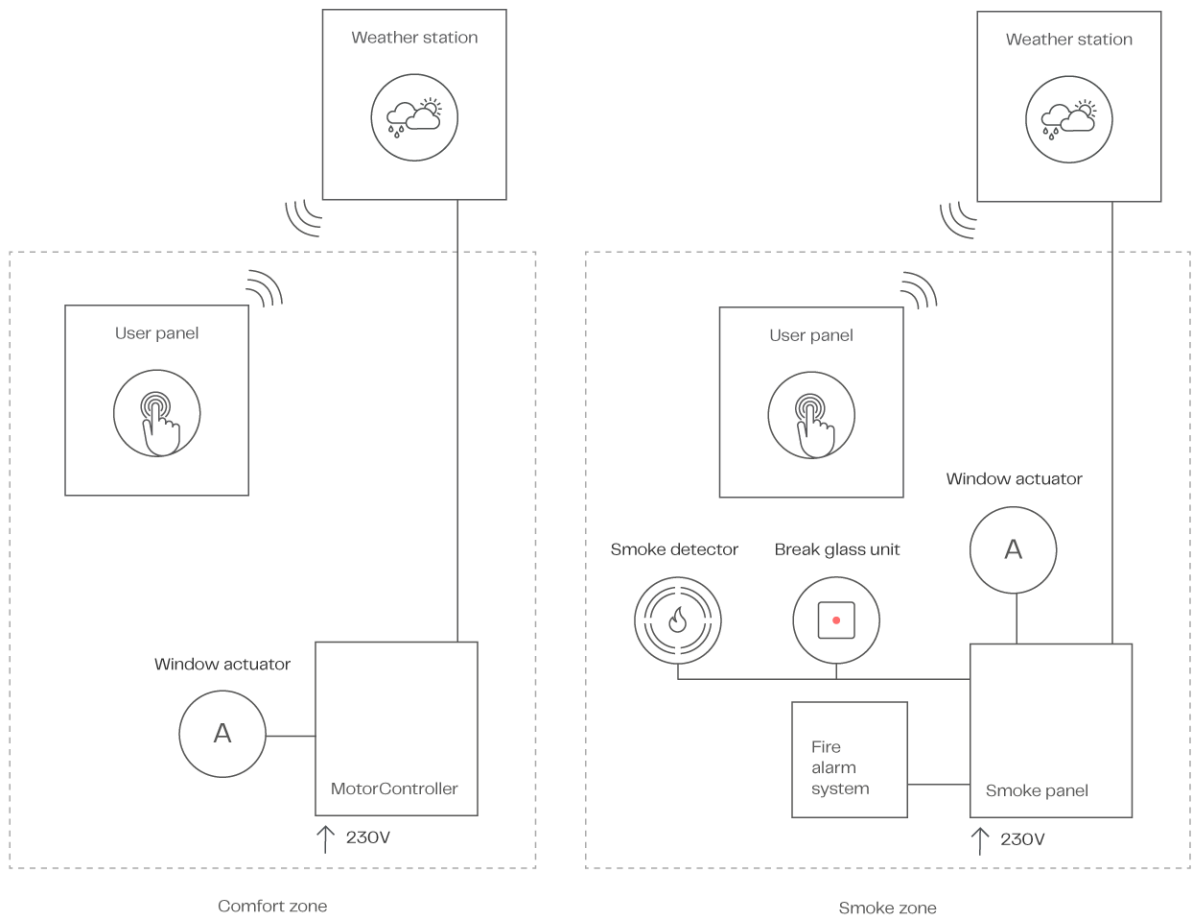

10.5.a With MotorController WCC

10.5.b In connection with Smoke ventilation unit WSC

## 10.6 Connection diagram for weather station

### 10.6.1 WCC 103 and WCC 106

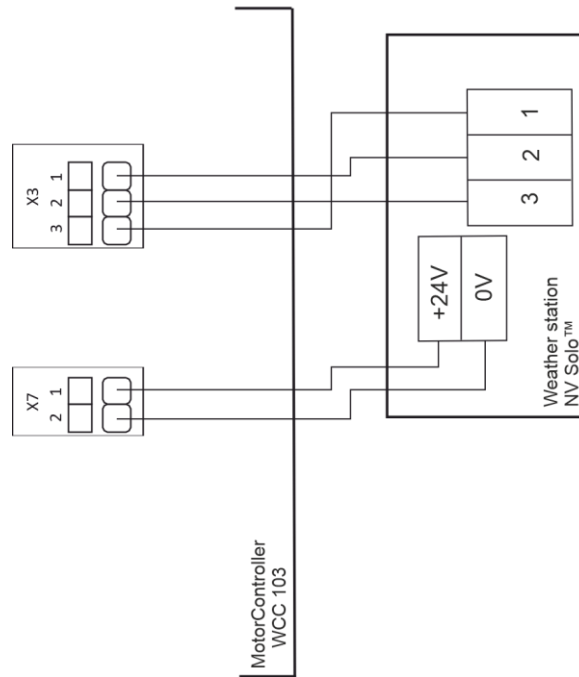
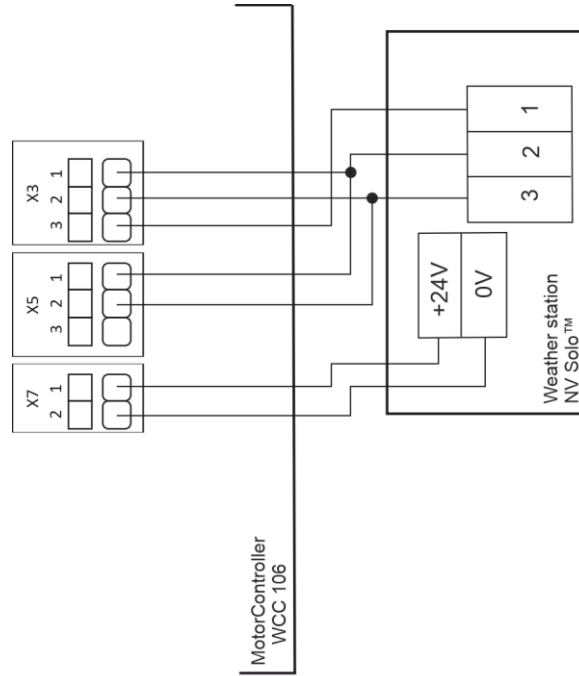

## 10.6.2 WCC 3x0 Standard

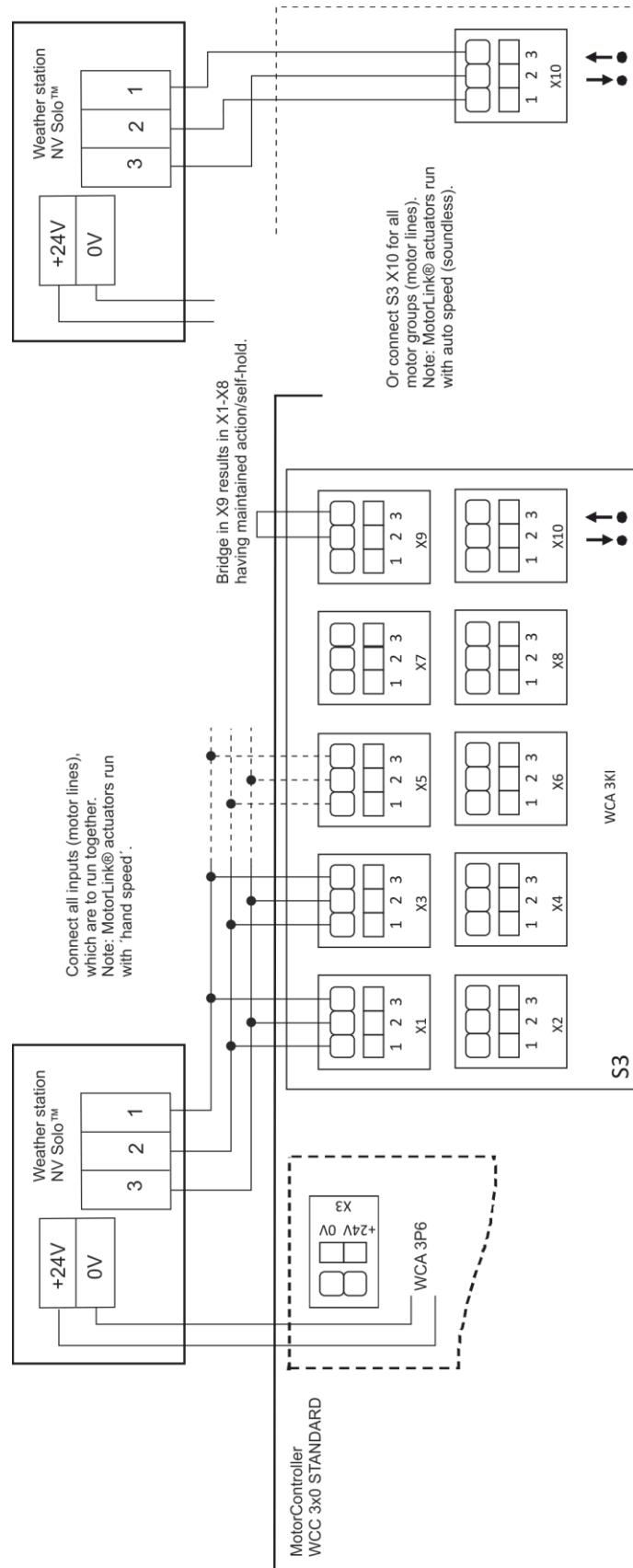

### 10.6.3 WCC 3x0 Plus, WSC 3x0 Standard and Plus

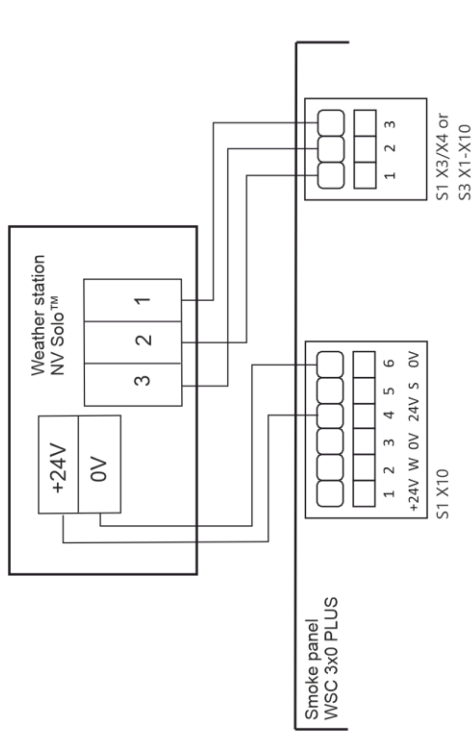

Input must be configured on the touch screen, see the configuration guide in the WCC instruction.

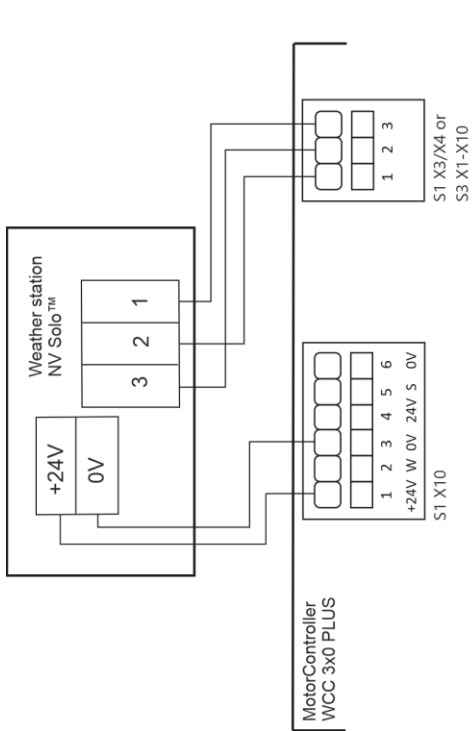

Input must be configured on the touch screen, see the configuration guide in the WCC instruction.

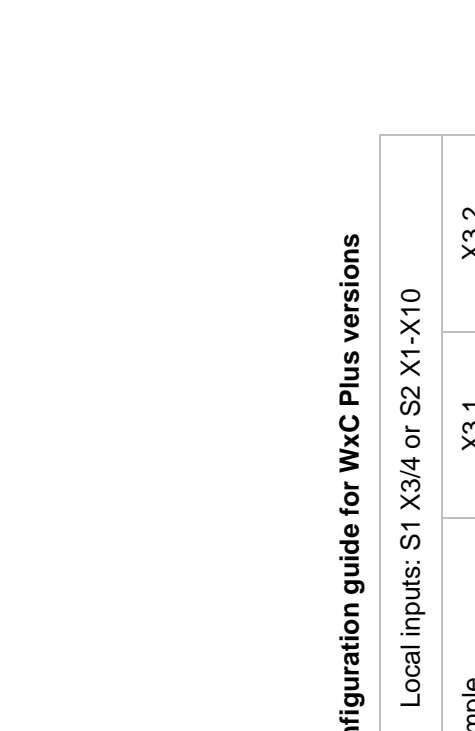
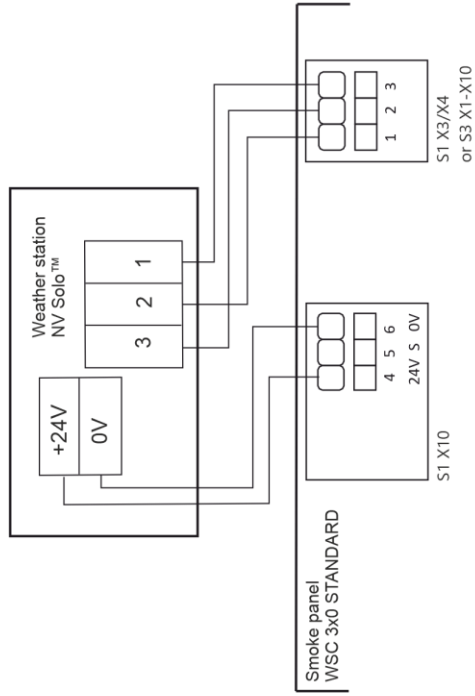

#### Input configuration guide for WxC Plus versions

Local inputs: S1 X3/4 or S2 X1-X10	
Input example	X3.1
Active function	Auto.open
Inactive function	Auto.stop
Short output function	-