



WMX 526 / 526 UL / 826 / 826 UL Chain actuator



Natural
ventilation

24V

±24V control



MotorLink®



UL certification
– Actuators

1.61

Description

- designed for surface mounting
- for comfort ventilation
- to be used with top hung, bottom hung and turning windows
- to be used together with ±24V control units or control units with MotorLink®
- can be used together with espagnolette WMB
- external safety edge can be connected directly to the actuator (actuator version 'E')
- available with and without UL certification:
 - Europe: order without UL certification
 - USA / Canada: order with UL certification (version UL)
- synchronization of up to four window actuators – no need for an external synchronization module
- genuine position feedback and three speeds when using control unit with MotorLink®
- soft close function
- built-in electronic load switch-off/end stop
- electronic actuator with micro controller
- the actuator has an integrated reverse function to ensure a prolonged life span of the window gaskets
- easy mounting

Actuator variants

The actuator is available in four different versions: single actuator (-1), double actuator (-2), triple actuator (-3) and quad actuator (-4).

The synchro actuators (-2, -3 and -4) are equipped with a synchronization function, in which the actuators communicate directly with each other, which ensures the actuators operate at exactly the same speed and position.

On large windows up to four actuators can be mounted on the same window – with no need for an external synchronization module.

Pressure safety function

The risk of entrapment is reduced as the actuators are programmed to reverse if they encounter obstacles when closing. The set points determining when the actuators are to reverse are individually adjustable.



Version S



Version E

Opening speeds

One speed:
Actuators connected to ± 24 VDC control units (e.g. WUC) can run with one speed – see the following page for opening speed.

Three speeds:
Actuators connected to control units with MotorLink® (e.g. WCC) can run with three different speeds:

- automatically control speed – actuators run slowly and almost soundlessly.
- manual control speed – actuators run faster and more audibly.
- H&S and safety control speed – actuators run fastest. H&S control always has highest priority.

Technical specifications	
Pressure force	See diagram
Traction force	See diagram
Locking force	3000N
Chain stroke	50 – 500mm in increments of 10mm. Special version up to 600mm possible (only for bottom hung windows) – contact WindowMaster for further information.
Speed	WMX 526 / 526 UL: 7mm/s WMX 826 / 826 UL: 9mm/s (programmable 3 - 9mm/s)
Sound pressure level	≤ 30 dBA (operational speed: 3 mm/s), ≤ 46 dBA (operational speed: 9,5 mm/s)
Window type	Tophung, bottomhung and turning windows
Window width	Min. 700mm, maximum width depends on the window construction and the number of window actuators
Window height	Min. 700mm, maximum height depends on the window construction and the number of window actuators
Power consumption	24V DC (max. 10% ripple)
Voltage	20-36V DC
Open-circuit voltage	Max. 36V DC
Current consumption	WMX 526 / 526 UL: max. 0.5A WMX 826 / 826 UL: max. 1A
Operating conditions	-5°C - +74°C. Max. 90% relative humidity (not condensing)
Switch-on-duration	ED 40% (max. 4min. per 10min)
Material	Lacquered zinc house with 13mm zinc cromate passivated steel chain and 3-core 0,34mm ² cable with fast-in/fast-on connectors for connection to the extension cable WLL WMX 526 / 826: 4.9m grey silicone cable WMX 526 / 826 E: 4.9m grey silicone cable and 1.9m grey silicone cable for connection to pressure safety strip WMX 526 UL / 826 UL: 1.9m UL listed/recognized cable in grey (grey actuator) or white (white actuator)
Colour	Aluminium (RAL 9006) or white (RAL 9010), other RAL colours available at additional price
Size	487 x 30,5 x 42mm (W x H x D)
Weight	1,3kg
IP rating	Surface mounted: IP 20, concealed: IP 32
Certification	Actuators with 'U' in the article no. are UL certified accordingly to UL 325 and CAN/CSA-22.2 No. 247-14 and is supplied with UL approved cables UL STYLE 2464
SHE test	WMX 526 / 526 UL / 826 UL: not SHE tested WMX 826: tested in accordance with DIN 18232-3, section 3.6 (30 minutes at 300°C)
Life span	Tested with 10,000 opening and closing movements
To be ordered separately	Brackets and standard extension cables type WLL
Note	We reserve the right to make technical changes

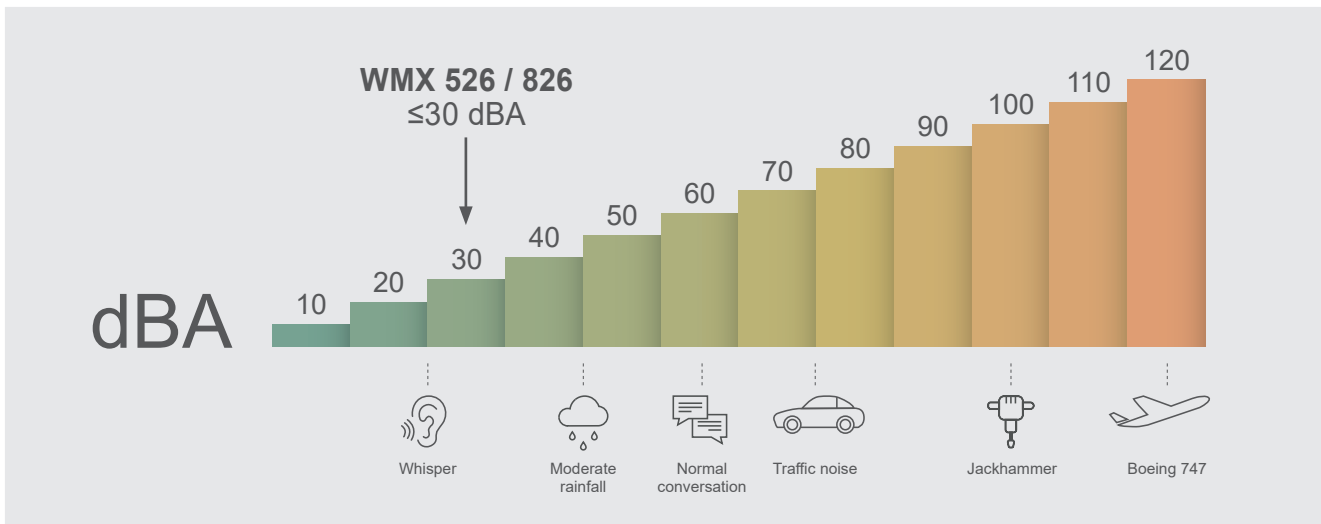

The sound pressure level was measured externally by The Danish Technological Institute. The measurements have been carried out in a large regular room size 7 x 14 x 2.4 m (W x L x H) with the ceiling covered with a standard sound absorbent material. The A-weighted sound pressure levels have been measured at a distance of 1 meter away from the surface of the actuators and at the height of 1.6 meters from the floor. The actuators were not installed on any window profile nor added any load. The full opening and full closing sound of the actuators have been measured and the result represents the average of the measurements.

Item code composition <i>(actuator supplied in sealed plastic packaging)</i>						
WMX 526 WMX 826	n	x	xxx	x	x	3
						Product version: 3
						Certification: 0 = CE, U = CE + UL
						Actuator hardware version: S = standard, E = with connection for pressure safety strip <i>(E: not UL actuator)</i>
						Chain opening: 50 – 500mm, in increments of 10mm (050 = 50mm)
						Colour: G = grey, W = white
						Actuator variant: 1= single, 2 = double, 3 = triple, 4 = quad
Explanation of product code structure						
WMX 526-2G070E 03		WMX 526 actuator, double synchronisation grey, 70mm chain opening, with connection for pressure safety strip, with CE certification, product version 3				

Items	Chain stroke [mm]	Length (L) [mm]	Item no.	Item no. with entrapment connection
Single actuator	50 - 500	487	WMX 526-1x ¹ xxx ² S x ³	WMX 526-1x ¹ xxx ² E 0
	50 - 500	487	WMX 826-1x ¹ xxx ² S x ³	WMX 826-1x ¹ xxx ² E 0
Double actuator	50 - 500	487	WMX 526-2x ¹ xxx ² S x ³	WMX 526-2x ¹ xxx ² E 0
	50 - 500	487	WMX 826-2x ¹ xxx ² S x ³	WMX 826-2x ¹ xxx ² E 0
Triple actuator	50 - 500	487	WMX 526-3x ¹ xxx ² S x ³	WMX 526-3x ¹ xxx ² E 0
	50 - 500	487	WMX 826-3x ¹ xxx ² S x ³	WMX 826-3x ¹ xxx ² E 0
Quad actuator	50 - 500	487	WMX 526-4x ¹ xxx ² S x ³	WMX 526-4x ¹ xxx ² E 0
	50 - 500	487	WMX 826-4x ¹ xxx ² S x ³	WMX 826-4x ¹ xxx ² E 0

¹ G = Grey, RAL 9006, W = White, RAL 9010.

² 50 – 500mm, in increments of 10mm (050 = 50mm)

³ The actuator can be supplied with certification according to UL 325

See also the table 'Product code composition' for further details as well as determination of final item no.

Accessories	Item no.
Chain bracket with tight-fitting bolt, WMX, for sash or frame	WAB 801
Chain bracket with split, for sash or frame	WAB 860
Chain bracket for wooden windows, for sash	WAB 867
Angle bracket for actuator, grey RAL 9006	WAB 804 0101
Angle bracket for actuator, white RAL 9010	WAB 804 1101
Z bracket for actuator WMX 504/804/524/824/526/826. Sash min 800mm.	WAB 805
Actuator bracket for buttomhung window	WAB 845
Actuator bracket	WAB 824B

See separate product sheets for further information.

Installation suggestion 1 - Inward opening

WAB 805

WAB 801

*** The cable cover must face towards the window hinge!**

Installation suggestion 2 - Outward opening

WAB 804 - 0101 grey / -1101 white

WAB 801

IMPORTANT!
Mount the actuator so the bottom of the housing faces towards the centre of the window

Installation suggestion 3 - Inward opening

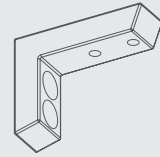
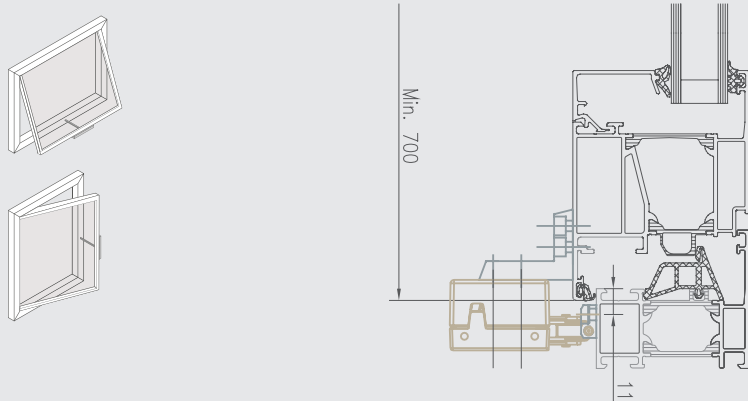

WAB 804 - 0101 grey / -1101 white

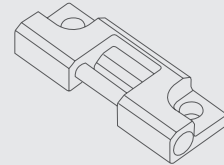

WAB 801

IMPORTANT!

Mount the actuator so the bottom of the housing faces towards the centre of the window

Installation suggestion 4 - Outward opening

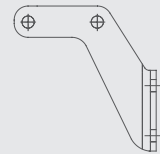
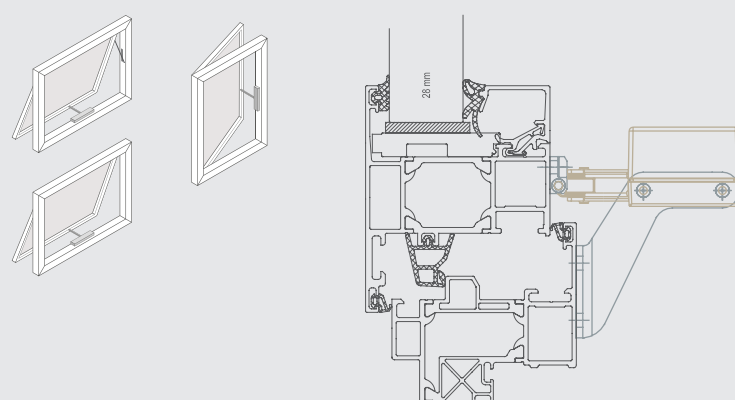

WAB 824B

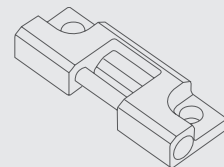

WAB 801

IMPORTANT!

Mount the actuator so the bottom of the housing faces towards the centre of the window

Installation suggestion 5 - Inward opening

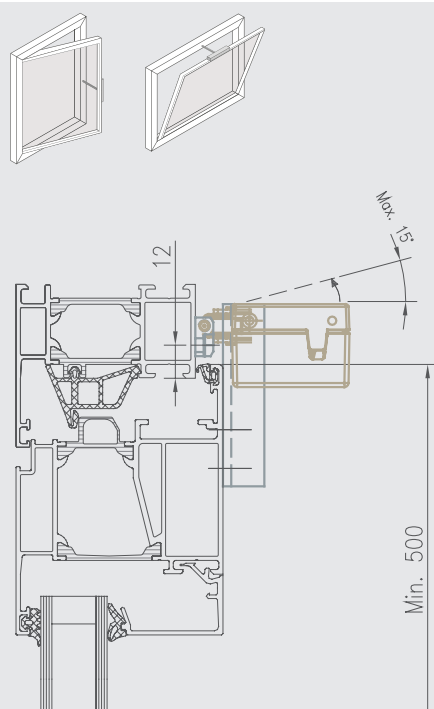

Actuator with limited 15° rotation mounted:

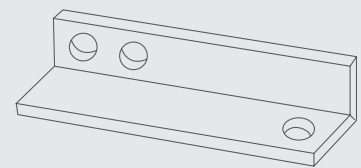
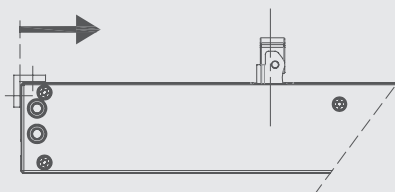

WAB 845

Actuator unlimited rotation mounted:

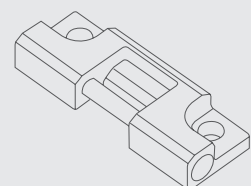
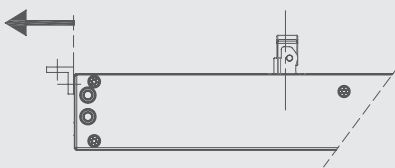

WAB 801

IMPORTANT! Mount the actuator so the bottom of the housing faces towards the centre of the window

WMX 526 / 526 UL / 826 / 826 UL

Chain actuator

Installation suggestion 6 - Outward opening

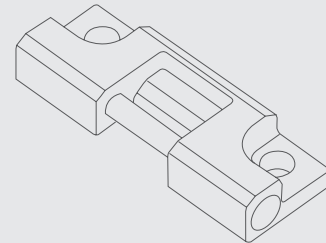
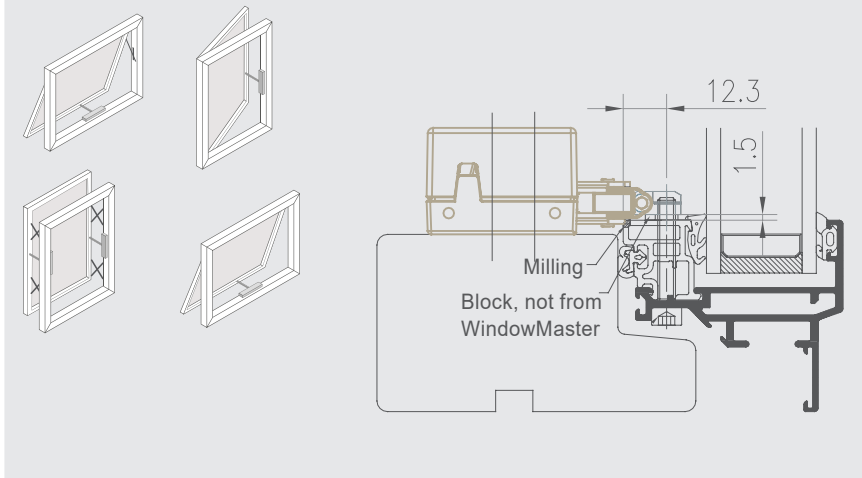

IMPORTANT!

Mount the actuator so the bottom of the housing faces towards the centre of the window

WAB 801

IMPORTANT!

Mount the actuator so the bottom of the housing (marked with a yellow label) faces towards the centre of the window

